

CURRENT OWNER		TOPO	UTILITIES	STRT / ROAD	LOCATION	CURRENT ASSESSMENT				
CLIFFORD, RICHARD W & ANNE M						Description	Code	Assessed	Assessed	801 FY2024 BARNSTABLE, MA
15 BOG BERRY LN						RESIDNTL	1010	524,900	524,900	
MARSTONS MIL MA 02648						RES LAND	1010	178,100	178,100	<b>VISION</b>
SUPPLEMENTAL DATA						Total		703,000	703,000	
Alt Prcl ID	Split Zonin	BID Parcel	ResExpt Q	YES: LOT 6	Plan Ref. 444/15	Land Ct#	#SR	Life Estate	PP STATU	
GIS ID	F_948512_2705923									

RECORD OF OWNERSHIP		BK-VOL/PAGE		SALE DATE	Q/U	V/I	SALE PRIC	VC	PREVIOUS ASSESSMENTS (HISTORY)								
CLIFFORD, RICHARD W & ANNE M		11427	0177	05-14-1998	U	V	59,000	1P	Year	Code	Assessed	Year	Code	Assessed	Year	Code	Assessed
CROWDER, DALE E JR & BYRNES, CAR		5914	0155	09-15-1987	U	V	225,000	D	2023	1010	358,800	2022	1010	296,500	2021	1010	270,500
										1010	176,000		1010	125,100		1010	125,100
									Total		534,800	Total		421,600	Total		398,700

EXEMPTIONS			OTHER ASSESSMENTS					
Year	Code	Description	Amount	Code	Description	Number	Amount	Comm Int
2024	5C	RESIDENTIAL EXEMPTION						
Total			0.00					

ASSESSING NEIGHBORHOOD			
Nbhd	Nbhd Name	B	Tracing
0106			MARSTM

NOTES			
This signature acknowledges a visit by a Data Collector or Assessor			
APPRAISED VALUE SUMMARY			
Appraised Bldg. Value (Card)			469,700
Appraised Xf (B) Value (Bldg)			50,600
Appraised Ob (B) Value (Bldg)			4,600
Appraised Land Value (Bldg)			178,100
Special Land Value			0
Total Appraised Parcel Value			703,000
Valuation Method			C
Total Appraised Parcel Value			703,000

BUILDING PERMIT RECORD								VISIT / CHANGE HISTORY						
Permit Id	Issue Date	Type	Description	Amount	Insp Date	% Comp	Date Comp	Comments	Date	Id	Type	Is	Cd	Purpost/Result
30580	04-28-1998	DW	Dwelling	126,800	07-15-1999	100	10-08-1998		08-02-2023	EG	03		16	In Office Review
									12-19-2022	SR	02		03	Cycl Insp Comp
									05-21-2020	LS			FR	Field Review
									02-27-2015	SR	01		03	Cycl Insp Comp
									02-24-2012	JR	03		15	Abatement Review

LAND LINE VALUATION SECTION																	
B	Use Code	Description	Zone	LA	Land Units	Unit Price	Size Adj	AC Disc	Site Index	Cond.	Nbhd.	Nbhd. Adj	Notes	Location Adjustmen	Adj Unit P	Land Value	
1	1010	Single Fam M-0	RF	3	0.430	AC	176,344.00	2.04234	1.0000	5	1.00	0106	1.150		1.0000	414,179.1	178,100
Total Card Land Units					0.43	AC	Parcel Total Land Area					0.43	Total Land Value			178,100	

CONSTRUCTION DETAIL			CONSTRUCTION DETAIL (CONTINUED)		
Element	Cd	Description	Element	Cd	Description
Style	03	Colonial			
Model	01	Residential			
Grade:	C+	Average Plus			
Stories	2.5	2 1/2 Stories			
Exterior Wall 1	14	Wood Shingle			
Exterior Wall 2	11	Clapboard			
RooF Structure	03	Gable/Hip			
RooF Cover	03	Asph/F Gls/Cmp			
Interior Wall 1	03	Plastered			
Interior Wall 2					
Interior Floor 1	12	Hardwood			
Interior Floor 2	14	Carpet			
Heat Fuel	03	Gas			
Heat Type	05	Hot Water			
AC Type	03	Central			
Bedrooms	03	3 Bedrooms			
Full Baths	2				
Half Baths	1				
Extra Fixtures					
Total Rooms	6	6 Rooms			
Bath Style					
Kitchen Style					
Occupancy					
Usrflid 105					
Accessory Apt					
Foundation Alt	01	Poured Conc.			
Rms Prts					
Bath Split	21	2 Full-1 Half			

CONDO DATA				
Parcel Id		C	Ownr	0.0
			B	S
Adjust Type	Code	Description	Factor%	
Condo Flr				
Condo Unit				

COST / MARKET VALUATION	
Building Value New	527,700
Year Built	1999
Effective Year Built	2005
Depreciation Code	A
Remodel Rating	
Year Remodeled	
Depreciation %	11
Functional Obsol	0
External Obsol	0
Trend Factor	1
Condition	
Condition %	
Percent Good	89
RCNLD	469,700
Dep % Ovr	
Dep Ovr Comment	
Misc Imp Ovr	
Misc Imp Ovr Comment	
Cost to Cure Ovr	
Cost to Cure Ovr Comment	

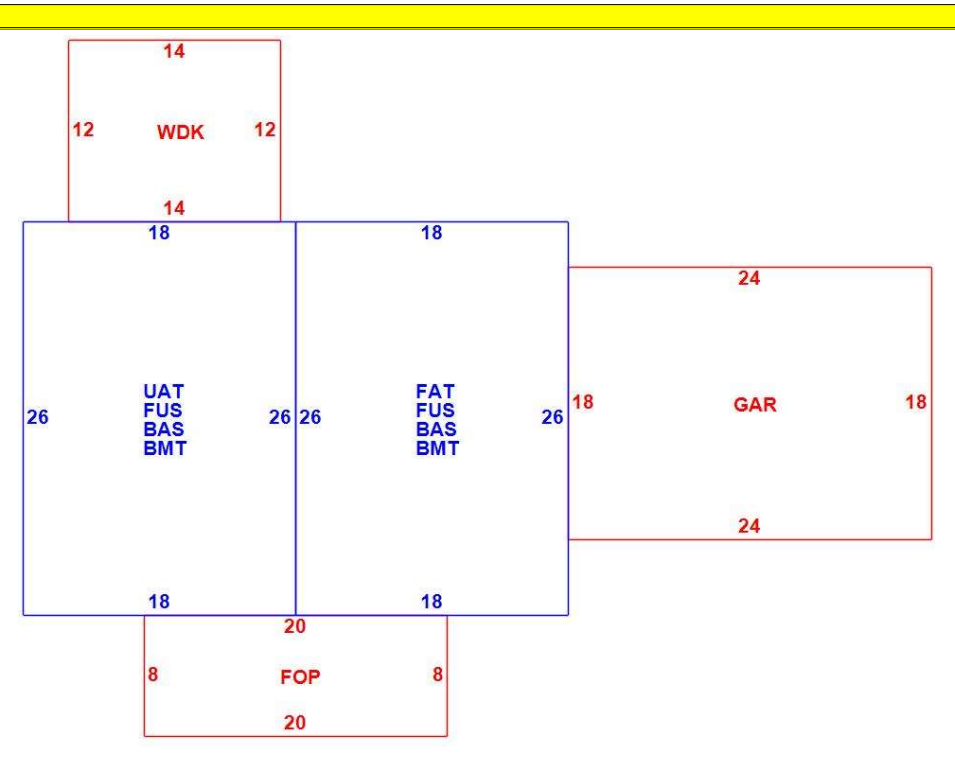

OB - OUTBUILDING & YARD ITEMS(L) / XF - BUILDING EXTRA FEATURES(B)										
Code	Description	L/B	Units	Unit Price	Yr Blt	Cond. Cd	% Gd	Grade	Grade Adj.	Appr. Value
FPL3	Fireplace 2 sto	B	1	7000.00	2007		89		0.00	6,200
WDC	Deck comp w	L	168	28.00	2007		76		0.00	4,600
FOP	Open Porch-ro	B	160	55.00	2007		89		0.00	6,800
GAR	Attached Gara	B	432	40.00	2007		89		0.00	15,000
BMT	Basement-Unfi	B	936	26.01	2007		89		0.00	22,600

BUILDING SUB-AREA SUMMARY SECTION						
Code	Description	Living Area	Floor Area	Eff Area	Unit Cost	Undeprec Value
BAS	First Floor	936	936	936	265.31	248,329
BMT	Basement Area	0	936	0	0.00	0
FAT	Attic, Finished	70	468	70	39.68	18,572
FOP	Open Porch	0	160	0	0.00	0
FUS	Upper Story	936	936	936	265.31	248,329
GAR	Attached Garage	0	432	0	0.00	0
UAT	Attic, Unfinished	0	468	47	26.64	12,470
WDK	Wood Deck	0	168	0	0.00	0
Ttl Gross Liv / Lease Area		1,942	4,504	1,989		527,700

