

CONSTRUCTION DETAIL			CONSTRUCTION DETAIL (CONTINUED)		
Element	Cd	Description	Element	Cd	Description
Style	04	Cape Cod			
Model	01	Residential			
Grade:	C+	Average Plus			
Stories	1.75	1 3/4 Stories			
Exterior Wall 1	25	Vinyl Siding			
Exterior Wall 2	11	Clapboard			
Roof Structure	03	Gable/Hip			
Roof Cover	03	Asph/F Gls/Cmp			
Interior Wall 1	03	Plastered			
Interior Wall 2					
Interior Floor 1	14	Carpet			
Interior Floor 2	12	Hardwood			
Heat Fuel	03	Gas			
Heat Type	04	Hot Air			
AC Type	03	Central			
Bedrooms	04	4 Bedrooms			
Full Baths	3				
Half Baths	0				
Extra Fixtures					
Total Rooms	8	8 Rooms			
Bath Style					
Kitchen Style					
Occupancy					
Usrflid 105					
Accessory Apt					
Foundation Alt	01	Poured Conc.			
Rms Prts					
Bath Split	30	3 Full-0 Half			
			CONDO DATA		
Parcel Id		C	Owne		0.0
Adjust Type		Code	Description		Factor%
Condo Flr		Condo Unit			
			COST / MARKET VALUATION		
Building Value New		700,312			
Year Built		1991			
Effective Year Built		2001			
Depreciation Code		A			
Remodel Rating					
Year Remodeled					
Depreciation %		14			
Functional Obsol		0			
External Obsol		0			
Trend Factor		1			
Condition					
Condition %					
Percent Good		86			
RCNLD		602,300			
Dep % Ovr					
Dep Ovr Comment					
Misc Imp Ovr					
Misc Imp Ovr Comment					
Cost to Cure Ovr					
Cost to Cure Ovr Comment					

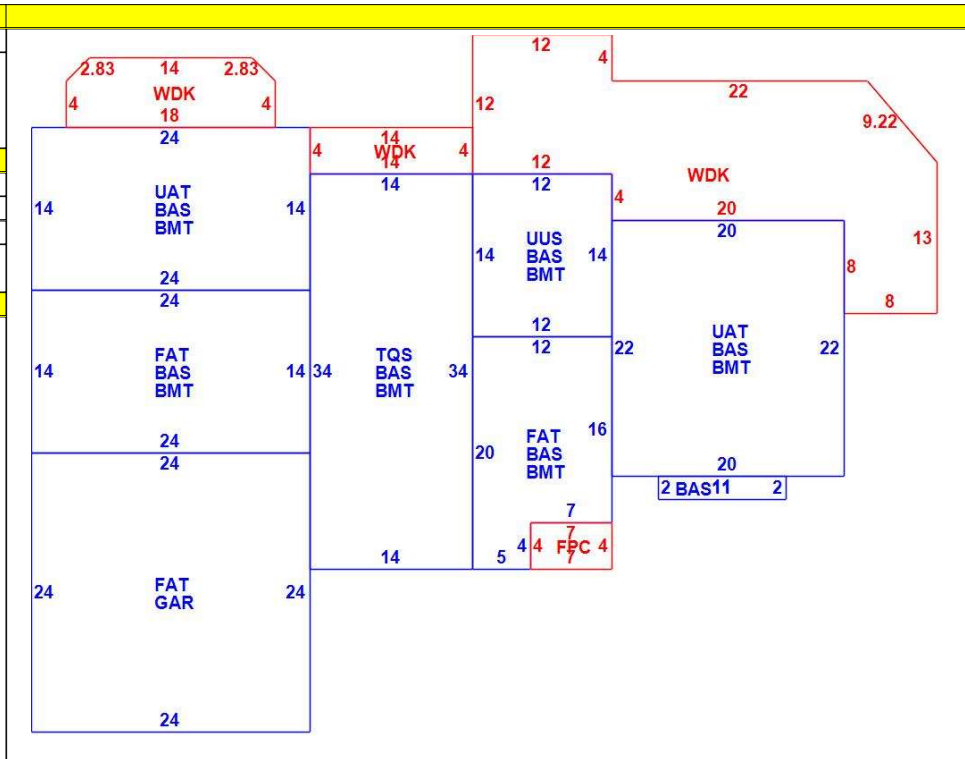

OB - OUTBUILDING & YARD ITEMS(L) / XF - BUILDING EXTRA FEATURES(B)										
Code	Description	L/B	Units	Unit Price	Yr Blt	Cond. Cd	% Gd	Grade	Grade Adj.	Appr. Value
FPL2	Fireplace 1.5 s	B	1	6000.00	2003		86		0.00	5,200
WDC	Wood Decking	L	683	20.00	2001		64		0.00	8,000
FOPC	Open Prch-roo	B	28	55.00	2003		86		0.00	1,600
GAR	Attached Gara	B	576	40.00	2003		86		0.00	17,600
BMT	Basement-Unfi	B	1,968	26.01	2003		86		0.00	38,000
GEN	Emergency Ge	L	1	5550.00	2009		80		0.00	4,400

BUILDING SUB-AREA SUMMARY SECTION						
Code	Description	Living Area	Floor Area	Eff Area	Unit Cost	Undeprec Value
BAS	First Floor	1,990	1,990	1,990	260.44	518,268
BMT	Basement Area	0	1,968	0	0.00	0
FAT	Attic, Finished	169	1,124	169	39.16	44,014
FPC	Open Porch Conc. Floor	0	28	0	0.00	0
GAR	Attached Garage	0	576	0	0.00	0
TQS	Three Quarter Story	309	476	309	169.06	80,475
UAT	Attic, Unfinished	0	776	78	26.18	20,314
UUS	Upper Story, Unfinished	0	168	143	221.68	37,242
WDK	Wood Deck	0	683	0	0.00	0
Ttl Gross Liv / Lease Area		2,468	7,789	2,689		700,313

