

| CURRENT OWNER | | TOPO | UTILITIES | STRT / ROAD | LOCATION | CURRENT ASSESSMENT | | | |
|---|--|----------------|---|-------------|----------|--------------------|------|----------|----------|
| HARPER, KRISTEN L 34 EMERALD LANE MARSTONS MIL MA 02648 | | 2 Above Street | 6 Septic | 1 Paved | | Description | Code | Assessed | Assessed |
| | | | 4 Gas | | | RESIDNTL | 1010 | 338,700 | 338,700 |
| | | | 2 Public Water | | | RES LAND | 1010 | 156,200 | 156,200 |
| SUPPLEMENTAL DATA | | | | | | | | | |
| Alt Prcl ID Split Zonin BID Parcel ResExpt Q YES: #DL 1 LOT 415 #DL 2 GIS ID F_948084_2709655 | | | Plan Ref. Land Ct# 30751-I #SR Life Estate PP STATU Assoc Pid# | | | Total | | 494,900 | 494,900 |

801
 FY2024
 BARNSTABLE, MA
VISION

| RECORD OF OWNERSHIP | | BK-VOL/PAGE | SALE DATE | Q/U | V/I | SALE PRIC | VC | PREVIOUS ASSESSMENTS (HISTORY) | | | | | | |
|--------------------------------|--|-------------|-----------|------------|-----|-----------|---------|--------------------------------|-------|-------|----------|-------|------|----------|
| HARPER, KRISTEN L | | D140828 | 0 | 09-10-2020 | U | I | 0 | 1F | Year | Code | Assessed | Year | Code | Assessed |
| HARPER, JAMES T JR & KRISTEN L | | C173631 | 0 | 07-06-2004 | Q | I | 315,000 | 00 | 2023 | 1010 | 337,900 | 2022 | 1010 | 287,200 |
| FERNALD, LAWRENCE & DEBORAH | | C136064 | 0 | 01-15-1995 | Q | I | 132,000 | 00 | | 1010 | 142,000 | 2021 | 1010 | 105,200 |
| PEREIRA, MICHAEL D & SUSAN I | | C101861 | 0 | 06-15-1985 | Q | I | 83,900 | 00 | | | | | 1010 | 2,800 |
| DAVIS, GLENN F & KRISTIN J | | C63568 | 0 | 12-27-1974 | U | | 0 | | Total | | 479,900 | Total | | 392,400 |
| | | Total | | | | | | | | Total | 359,100 | | | |

| EXEMPTIONS | | | OTHER ASSESSMENTS | | | | | |
|------------|------|-----------------------|-------------------|------|-------------|--------|--------|----------|
| Year | Code | Description | Amount | Code | Description | Number | Amount | Comm Int |
| 2011 | 5C | RESIDENTIAL EXEMPTION | 0.00 | | | | | |
| Total | | | 0.00 | | | | | |

This signature acknowledges a visit by a Data Collector or Assessor

| ASSESSING NEIGHBORHOOD | | | |
|------------------------|-----------|---|---------|
| Nbhd | Nbhd Name | B | Tracing |
| 0105 | | | MARSTM |

| APPRAISED VALUE SUMMARY | |
|-------------------------------|---------|
| Appraised Bldg. Value (Card) | 289,900 |
| Appraised Xf (B) Value (Bldg) | 45,200 |
| Appraised Ob (B) Value (Bldg) | 3,600 |
| Appraised Land Value (Bldg) | 156,200 |
| Special Land Value | 0 |
| Total Appraised Parcel Value | 494,900 |
| Valuation Method | C |
| Total Appraised Parcel Value | 494,900 |

| NOTES | | | | | | | |
|-------|--|--|--|--|--|--|--|
| | | | | | | | |

| BUILDING PERMIT RECORD | | | | | | | | VISIT / CHANGE HISTORY | | | | | | |
|------------------------|------------|------|-------------|--------|------------|--------|------------|------------------------|------------|----|------|----|----|----------------------------|
| Permit Id | Issue Date | Type | Description | Amount | Insp Date | % Comp | Date Comp | Comments | Date | Id | Type | Is | Cd | Purpost/Result |
| B32030 | 06-01-1988 | AD | Addition | 5,575 | 01-15-1989 | 100 | 12-31-1989 | | 12-06-2022 | SR | 01 | | 03 | Cycl Insp Comp |
| B30082 | 10-02-1986 | AD | Addition | 2,700 | 01-15-1987 | 100 | 12-31-1987 | | 05-15-2020 | LS | | | FR | Field Review |
| B30082A | 10-01-1986 | AD | Addition | 0 | 01-15-1987 | 100 | 12-31-1987 | | 05-03-2017 | SR | 02 | | 14 | Cyclical Inspection |
| B28437 | 09-02-1985 | AD | Addition | 8,000 | 01-15-1986 | 100 | 12-31-1986 | | 08-10-2005 | PT | 02 | | 01 | Meas/Est |
| B28437A | 09-01-1985 | AD | Addition | 0 | 01-15-1986 | 100 | 12-31-1986 | | 03-23-1999 | DD | 01 | | 00 | Meas/Listed-Interior Acces |
| B19060 | 03-01-1977 | DW | Dwelling | 0 | 01-15-1978 | 100 | 12-31-1978 | | 03-15-1989 | ML | 01 | | 00 | Meas/Listed-Interior Acces |

| LAND LINE VALUATION SECTION | | | | | | | | | | | | | | | | | |
|-----------------------------|----------|----------------|------|----|------------|------------|------------------------|---------|------------|-------|-------|-----------|------------------|--------------------|------------|------------|---------|
| B | Use Code | Description | Zone | LA | Land Units | Unit Price | Size Adj | AC Disc | Site Index | Cond. | Nbhd. | Nbhd. Adj | Notes | Location Adjustmen | Adj Unit P | Land Value | |
| 1 | 1010 | Single Fam M-0 | RF | 3 | 0.470 | AC | 176,344.00 | 1.88432 | 1.0000 | 5 | 1.00 | 0105 | 1.000 | | 1.0000 | 332,285 | 156,200 |
| Total Card Land Units | | | | | 0.47 | AC | Parcel Total Land Area | | | | | 0.47 | Total Land Value | | | 156,200 | |

| CONSTRUCTION DETAIL | | | CONSTRUCTION DETAIL (CONTINUED) | | |
|---------------------|------|----------------|---------------------------------|------|-------------|
| Element | Cd | Description | Element | Cd | Description |
| Style | 05 | Saltbox | | | |
| Model | 01 | Residential | | | |
| Grade: | C | Average | | | |
| Stories | 1.75 | 1 3/4 Stories | | | |
| Exterior Wall 1 | 11 | Clapboard | | | |
| Exterior Wall 2 | | | | | |
| RooF Structure | 03 | Gable/Hip | | | |
| RooF Cover | 03 | Asph/F Gls/Cmp | | | |
| Interior Wall 1 | 05 | Drywall | | | |
| Interior Wall 2 | | | | | |
| Interior Floor 1 | 09 | Pine/Soft Wood | | | |
| Interior Floor 2 | | | | | |
| Heat Fuel | 03 | Gas | | | |
| Heat Type | 05 | Hot Water | | | |
| AC Type | 01 | None | | | |
| Bedrooms | 03 | 3 Bedrooms | | | |
| Full Baths | 2 | | | | |
| Half Baths | 0 | | | | |
| Extra Fixtures | | | | | |
| Total Rooms | 9 | 9 Rooms | | | |
| Bath Style | | | | | |
| Kitchen Style | | | | | |
| Occupancy | | | | | |
| Usrflid 105 | | | | | |
| Accessory Apt | | | | | |
| Foundation Alt | 01 | Poured Conc. | | | |
| Rms Prts | | | | | |
| Bath Split | 20 | 2 Full-0 Half | | | |
| | | | CONDO DATA | | |
| | | | Parcel Id | C | Ownr 0.0 |
| | | | | B | S |
| | | | Adjust Type | Code | Description |
| | | | Condo Flr | | Factor% |
| | | | Condo Unit | | |
| | | | COST / MARKET VALUATION | | |
| | | | Building Value New | | 357,922 |
| | | | Year Built | | 1977 |
| | | | Effective Year Built | | 1994 |
| | | | Depreciation Code | | A |
| | | | Remodel Rating | | |
| | | | Year Remodeled | | |
| | | | Depreciation % | | 19 |
| | | | Functional Obsol | | 0 |
| | | | External Obsol | | 0 |
| | | | Trend Factor | | 1 |
| | | | Condition | | |
| | | | Condition % | | |
| | | | Percent Good | | 81 |
| | | | RCNLD | | 289,900 |
| | | | Dep % Ovr | | |
| | | | Dep Ovr Comment | | |
| | | | Misc Imp Ovr | | |
| | | | Misc Imp Ovr Comment | | |
| | | | Cost to Cure Ovr | | |
| | | | Cost to Cure Ovr Comment | | |

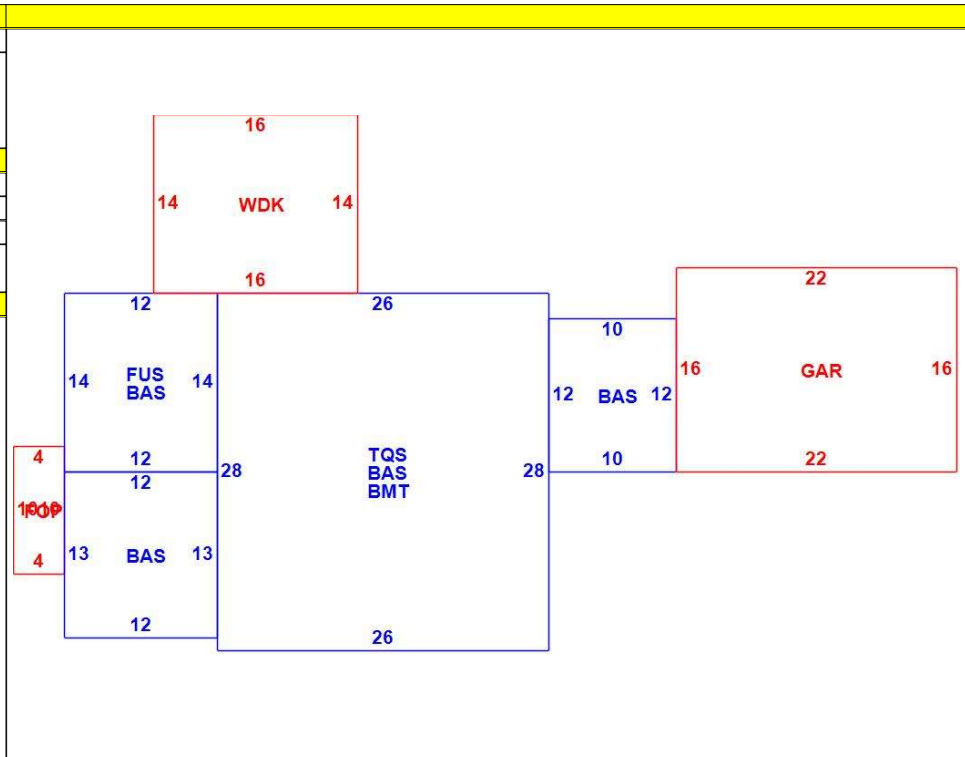

| OB - OUTBUILDING & YARD ITEMS(L) / XF - BUILDING EXTRA FEATURES(B) | | | | | | | | | | |
|--|-----------------|-----|-------|------------|--------|----------|------|-------|------------|-------------|
| Code | Description | L/B | Units | Unit Price | Yr Blt | Cond. Cd | % Gd | Grade | Grade Adj. | Appr. Value |
| FPL2 | Fireplace 1.5 s | B | 1 | 6000.00 | 1996 | | 81 | | 0.00 | 4,900 |
| BFA | Bsmt Fin-Avg | B | 600 | 17.36 | 1996 | | 81 | | 0.00 | 8,400 |
| WDC | Wood Decking | L | 224 | 20.00 | 1997 | | 56 | | 0.00 | 2,800 |
| FOP | Open Porch-ro | B | 40 | 55.00 | 1996 | | 81 | | 0.00 | 2,400 |
| GAR | Attached Gara | B | 352 | 40.00 | 1996 | | 81 | | 0.00 | 12,000 |
| BMT | Basement-Unfi | B | 728 | 26.01 | 1996 | | 81 | | 0.00 | 17,500 |
| SHED | Shed | L | 80 | 18.00 | 1997 | | 56 | | 0.00 | 800 |

| BUILDING SUB-AREA SUMMARY SECTION | | | | | | |
|-----------------------------------|---------------------|-------------|------------|----------|-----------|----------------|
| Code | Description | Living Area | Floor Area | Eff Area | Unit Cost | Undeprec Value |
| BAS | First Floor | 1,172 | 1,172 | 1,172 | 197.42 | 231,376 |
| BMT | Basement Area | 0 | 728 | 0 | 0.00 | 0 |
| FOP | Open Porch | 0 | 40 | 0 | 0.00 | 0 |
| FUS | Upper Story | 168 | 168 | 168 | 197.42 | 33,167 |
| GAR | Attached Garage | 0 | 352 | 0 | 0.00 | 0 |
| TQS | Three Quarter Story | 473 | 728 | 473 | 128.27 | 93,380 |
| WDK | Wood Deck | 0 | 224 | 0 | 0.00 | 0 |
| Ttl Gross Liv / Lease Area | | 1,813 | 3,412 | 1,813 | | 357,923 |

