

| CURRENT OWNER | | | | TOPO | UTILITIES | STRT / ROAD | LOCATION | CURRENT ASSESSMENT | | | | 801 FY2024 BARNSTABLE, MA VISION | |
|-------------------------|--|--|--|-----------------|-----------|-------------|----------|--------------------|------|----------|----------|--|-----------|
| SCHLEGEL, PAUL F | | | | | | | | Description | Code | Assessed | Assessed | | |
| 2525 SE 12 STREET | | | | | | | | RESIDNTL | 1010 | 966,300 | 966,300 | | |
| POMPANO BEA FL 33062 | | | | | | | | RES LAND | 1010 | 176,300 | 176,300 | | |
| SUPPLEMENTAL DATA | | | | | | | | Total | | | | 1,142,600 | 1,142,600 |
| Alt Prcl ID | | | | Plan Ref. 470/7 | | | | | | | | | |
| Split Zonin | | | | Land Ct# | | | | | | | | | |
| BID Parcel | | | | #SR | | | | | | | | | |
| ResExpt Q NO APP: | | | | Life Estate | | | | | | | | | |
| #DL 1 LOT 2 | | | | PP STATU | | | | | | | | | |
| #DL 2 | | | | Assoc Pid# | | | | | | | | | |
| GIS ID F_947444_2712739 | | | | | | | | | | | | | |

| RECORD OF OWNERSHIP | | | | BK-VOL/PAGE | SALE DATE | Q/U | V/I | SALE PRIC | VC | PREVIOUS ASSESSMENTS (HISTORY) | | | | | | | | | | |
|---------------------------------|--|--|--|-------------|-----------|------------|-----|-----------|-----------|--------------------------------|------|-------|----------|-----------|-------|----------|---------|-------|----------|---------|
| SCHLEGEL, PAUL F | | | | 34410 | 219 | 08-25-2021 | Q | I | 1,070,000 | 00 | Year | Code | Assessed | Year | Code | Assessed | Year | Code | Assessed | |
| LALLIER, MICHAEL R TR | | | | 15249 | 0090 | 06-11-2002 | U | I | 110,000 | 1P | 2023 | 1010 | 857,300 | 2022 | 1010 | 728,000 | 2021 | 1010 | 621,800 | |
| SCHAEFER, STEPHEN W & CATHERINE | | | | 7856 | 0305 | 01-15-1992 | U | V | 1 | 1A | | 1010 | 160,300 | | 1010 | 118,800 | | 1010 | 118,800 | |
| LEBEL, JOHN S & SCHAEFER, | | | | 7435 | 0159 | 02-15-1991 | U | V | 1 | 1A | | | | | | | | 1010 | 6,500 | |
| LEBEL, JOHN S & SCHAEFER, | | | | 7397 | 0100 | 12-15-1990 | U | V | 1 | 1A | | | | | | | | | | |
| Total | | | | | | | | | | | | Total | | 1,017,600 | Total | | 846,800 | Total | | 747,100 |

| EXEMPTIONS | | | | OTHER ASSESSMENTS | | | | This signature acknowledges a visit by a Data Collector or Assessor | | | | | | | | | | | | |
|------------|------|--------------------------|--------|-------------------|-------------|--------|--------|---|--|--|--|--|--|--|--|--|--|--|--|--|
| Year | Code | Description | Amount | Code | Description | Number | Amount | Comm Int | | | | | | | | | | | | |
| 2023 | N5C | NO RESIDENTIAL EXEMPTION | 0.00 | | | | | | | | | | | | | | | | | |
| Total | | | 0.00 | | | | | | | | | | | | | | | | | |

| ASSESSING NEIGHBORHOOD | | | | APPRAISED VALUE SUMMARY | | | | | | | | | | | | |
|--|-----------|--|---|-------------------------|--------|--|--|--|--|--|--|--|--|--|--|--|
| Nbhd | Nbhd Name | | B | Tracing | Batch | | | | | | | | | | | |
| 0105 | | | | | MARSTM | | | | | | | | | | | |
| NOTES | | | | | | | | | | | | | | | | |
| Appraised Bldg. Value (Card) 860,800 | | | | | | | | | | | | | | | | |
| Appraised Xf (B) Value (Bldg) 99,000 | | | | | | | | | | | | | | | | |
| Appraised Ob (B) Value (Bldg) 6,500 | | | | | | | | | | | | | | | | |
| Appraised Land Value (Bldg) 176,300 | | | | | | | | | | | | | | | | |
| Special Land Value 0 | | | | | | | | | | | | | | | | |
| Total Appraised Parcel Value 1,142,600 | | | | | | | | | | | | | | | | |
| Valuation Method C | | | | | | | | | | | | | | | | |
| Total Appraised Parcel Value 1,142,600 | | | | | | | | | | | | | | | | |

| BUILDING PERMIT RECORD | | | | | | | | | VISIT / CHANGE HISTORY | | | | | | |
|------------------------|------------|------|-------------|---------|------------|--------|------------|----------|------------------------|----|------|----|----|-------------------|--|
| Permit Id | Issue Date | Type | Description | Amount | Insp Date | % Comp | Date Comp | Comments | Date | Id | Type | Is | Cd | Purpost/Result | |
| 58861 | 03-07-2002 | DW | Dwelling | 224,832 | 03-02-2005 | 100 | 06-30-2007 | | 01-04-2022 | BM | 03 | | 16 | In Office Review | |
| | | | | | | | | | 05-20-2020 | LS | | | FR | Field Review | |
| | | | | | | | | | 10-18-2019 | CK | 03 | | 16 | In Office Review | |
| | | | | | | | | | 07-26-2019 | AC | 01 | | 03 | Cycl Insp Comp | |
| | | | | | | | | | 06-21-2018 | LH | 03 | | 16 | In Office Review | |
| | | | | | | | | | 03-28-2018 | MD | 22 | | 22 | Change of Address | |
| | | | | | | | | | 02-26-2018 | MD | 22 | | 22 | Change of Address | |

| LAND LINE VALUATION SECTION | | | | | | | | | | | | | | | | | |
|-----------------------------|----------|----------------|------|----|------------|------------|------------------------|---------|------------|-------|-------|-----------|------------------|--------------------|------------|------------|---------|
| B | Use Code | Description | Zone | LA | Land Units | Unit Price | Size Adj | AC Disc | Site Index | Cond. | Nbhd. | Nbhd. Adj | Notes | Location Adjustmen | Adj Unit P | Land Value | |
| 1 | 1010 | Single Fam M-0 | RF | 3 | 1.000 | AC | 176,344.00 | 1.00000 | 1.0000 | 5 | 1.00 | 0105 | 1.000 | | 1.0000 | 176,344 | 176,300 |
| Total Card Land Units | | | | | 1.00 | AC | Parcel Total Land Area | | | | | 1.00 | Total Land Value | | | 176,300 | |

| CONSTRUCTION DETAIL | | | CONSTRUCTION DETAIL (CONTINUED) | | |
|---------------------|-----|----------------|--------------------------------------|----|-------------|
| Element | Cd | Description | Element | Cd | Description |
| Style | 04 | Cape Cod | | | |
| Model | 01 | Residential | | | |
| Grade: | C+ | Average Plus | | | |
| Stories | 1.5 | 1 1/2 Stories | | | |
| Exterior Wall 1 | 14 | Wood Shingle | | | |
| Exterior Wall 2 | | | | | |
| Roof Structure | 03 | Gable/Hip | | | |
| Roof Cover | 03 | Asph/F Gls/Cmp | | | |
| Interior Wall 1 | 03 | Plastered | | | |
| Interior Wall 2 | | | | | |
| Interior Floor 1 | 12 | Hardwood | | | |
| Interior Floor 2 | | | | | |
| Heat Fuel | 03 | Gas | | | |
| Heat Type | 04 | Hot Air | | | |
| AC Type | 03 | Central | | | |
| Bedrooms | 03 | 3 Bedrooms | | | |
| Full Baths | 3 | | | | |
| Half Baths | 0 | | | | |
| Extra Fixtures | | | | | |
| Total Rooms | 8 | | | | |
| Bath Style | | | | | |
| Kitchen Style | | | | | |
| Occupancy | | | | | |
| Usrflid 105 | | | | | |
| Accessory Apt | | | | | |
| Foundation Alt | 01 | Poured Conc. | | | |
| Rms Prts | | | | | |
| Bath Split | 30 | 3 Full-0 Half | | | |
| | | | CONDO DATA | | |
| | | | Parcel Id | C | Owne 0.0 |
| | | | Adjust Type Code Description Factor% | | |
| | | | Condo Flr | | |
| | | | Condo Unit | | |
| | | | COST / MARKET VALUATION | | |
| | | | Building Value New | | 945,896 |
| | | | Year Built | | 2004 |
| | | | Effective Year Built | | 2008 |
| | | | Depreciation Code | | A |
| | | | Remodel Rating | | |
| | | | Year Remodeled | | |
| | | | Depreciation % | | 9 |
| | | | Functional Obsol | | 0 |
| | | | External Obsol | | 0 |
| | | | Trend Factor | | 1 |
| | | | Condition | | |
| | | | Condition % | | |
| | | | Percent Good | | 91 |
| | | | RCNLD | | 860,800 |
| | | | Dep % Ovr | | |
| | | | Dep Ovr Comment | | |
| | | | Misc Imp Ovr | | |
| | | | Misc Imp Ovr Comment | | |
| | | | Cost to Cure Ovr | | |
| | | | Cost to Cure Ovr Comment | | |

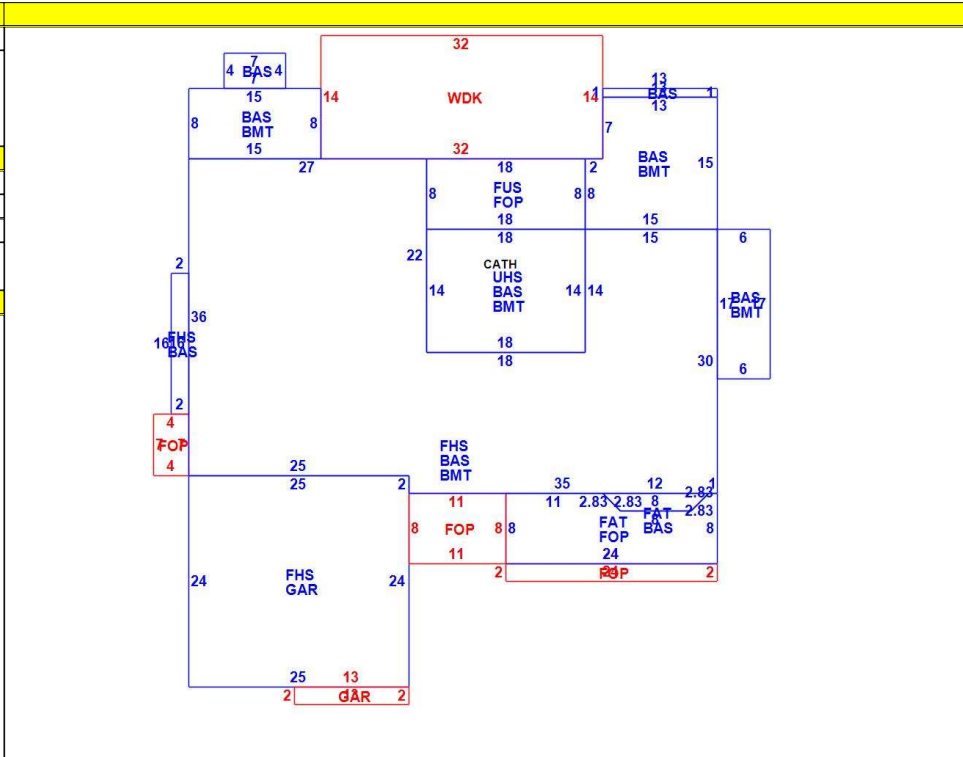

| OB - OUTBUILDING & YARD ITEMS(L) / XF - BUILDING EXTRA FEATURES(B) | | | | | | | | | | |
|--|-----------------|-----|-------|------------|--------|----------|------|-------|------------|-------------|
| Code | Description | L/B | Units | Unit Price | Yr Blt | Cond. Cd | % Gd | Grade | Grade Adj. | Appr. Value |
| FPL2 | Fireplace 1.5 s | B | 2 | 6000.00 | 2010 | | 91 | | 0.00 | 10,900 |
| WDC | Wood Decking | L | 448 | 20.00 | 2007 | | 76 | | 0.00 | 6,500 |
| FOP | Open Porch-ro | B | 480 | 55.00 | 2010 | | 91 | | 0.00 | 16,900 |
| GAR | Attached Gara | B | 626 | 40.00 | 2010 | | 91 | | 0.00 | 19,700 |
| BMT | Basement-Unfi | B | 2,399 | 26.01 | 2010 | | 91 | | 0.00 | 46,900 |
| FPLG | Gas Fireplace- | B | 2 | 2500.00 | 2010 | | 91 | | 0.00 | 4,600 |

| BUILDING SUB-AREA SUMMARY SECTION | | | | | | |
|-----------------------------------|------------------------|-------------|------------|----------|-----------|----------------|
| Code | Description | Living Area | Floor Area | Eff Area | Unit Cost | Undeprec Value |
| BAS | First Floor | 2,492 | 2,492 | 2,492 | 241.67 | 602,242 |
| BMT | Basement Area | 0 | 2,399 | 0 | 0.00 | 0 |
| FAT | Attic, Finished | 29 | 192 | 29 | 36.50 | 7,008 |
| FHS | Half Story | 1,173 | 2,346 | 1,173 | 120.84 | 283,479 |
| FOP | Open Porch | 0 | 480 | 0 | 0.00 | 0 |
| FUS | Upper Story | 144 | 144 | 144 | 241.67 | 34,800 |
| GAR | Attached Garage | 0 | 626 | 0 | 0.00 | 0 |
| UHS | Half Story, Unfinished | 0 | 252 | 76 | 72.88 | 18,367 |
| WDK | Wood Deck | 0 | 448 | 0 | 0.00 | 0 |
| Ttl Gross Liv / Lease Area | | 3,838 | 9,379 | 3,914 | | 945,896 |

