

| CURRENT OWNER | | TOPO | UTILITIES | STRT / ROAD | LOCATION | CURRENT ASSESSMENT | | | | 801 FY2024 BARNSTABLE, MA VISION | |
|--|--|---------|----------------|--|--------------|--------------------|------|-----------|-----------|--|-----------|
| MARTIGNETTI, TERESA C/O MARTIGNETTI, CARL J 500 JOHN HANCOCK ROAD TAUNTON MA 02780 | | 1 Level | 2 Public Water | 1 Paved | 7 Waterfront | Description | Code | Assessed | Assessed | | |
| | | | 6 Septic | | 1 Excel View | RESIDENTL | 1010 | 3,327,400 | 3,327,400 | | |
| | | | | | | RES LAND | 1010 | 5,260,800 | 5,260,800 | | |
| SUPPLEMENTAL DATA | | | | | | Total | | | | 8,588,200 | 8,588,200 |
| Alt Prcl ID Split Zonin BID Parcel ResExpt Q #DL 1 LOT 2 #DL 2 GIS ID F_950604_2687543 | | | | Plan Ref. 329/38 Land Ct# #SR Life Estate PP STATU Assoc Pid# | | | | | | | |

| RECORD OF OWNERSHIP | | BK-VOL/PAGE | SALE DATE | Q/U | V/I | SALE PRIC | VC | PREVIOUS ASSESSMENTS (HISTORY) | | | | | | | | |
|--|--|-------------|------------|-----|-----|-----------|----|--------------------------------|------|-----------|-------|------|-----------|-------|------|-----------|
| MARTIGNETTI, TERESA MARTIGNETTI, FERDINAND & TERESA BIRMINGHAM, PAUL J | | 14181 0256 | 08-29-2001 | U | I | 0 | 1A | Year | Code | Assessed | Year | Code | Assessed | Year | Code | Assessed |
| | | 10008 0270 | 01-15-1996 | Q | I | 1,775,000 | 00 | 2023 | 1010 | 2,571,600 | 2022 | 1010 | 2,384,200 | 2021 | 1010 | 1,895,900 |
| | | 2936 0216 | 06-18-1979 | U | | 0 | | | 1010 | 4,812,000 | | 1010 | 4,560,300 | | 1010 | 4,299,700 |
| | | | | | | | | Total | | 7,383,600 | Total | | 6,944,500 | Total | | 6,353,000 |

| EXEMPTIONS | | | | OTHER ASSESSMENTS | | | | This signature acknowledges a visit by a Data Collector or Assessor | | | | | | | | |
|------------|------|-------------|--------|-------------------|-------------|--------|--------|---|--|--|--|--|--|--|--|--|
| Year | Code | Description | Amount | Code | Description | Number | Amount | Comm Int | | | | | | | | |
| | | | | | | | | | | | | | | | | |
| Total | | | 0.00 | | | | | | | | | | | | | |

| ASSESSING NEIGHBORHOOD | | | | APPRAISED VALUE SUMMARY | | | | |
|------------------------|-----------|---|---------|-------------------------------|--|--|--|-----------|
| Nbhd | Nbhd Name | B | Tracing | Batch | | | | |
| WF14 | | | | OSTVIL | | | | |
| NOTES | | | | Appraised Bldg. Value (Card) | | | | 3,092,000 |
| | | | | Appraised Xf (B) Value (Bldg) | | | | 77,900 |
| | | | | Appraised Ob (B) Value (Bldg) | | | | 157,500 |
| | | | | Appraised Land Value (Bldg) | | | | 5,260,800 |
| | | | | Special Land Value | | | | 0 |
| | | | | Total Appraised Parcel Value | | | | 8,588,200 |
| | | | | Valuation Method | | | | C |
| | | | | Total Appraised Parcel Value | | | | 8,588,200 |

| BUILDING PERMIT RECORD | | | | | | | | | VISIT / CHANGE HISTORY | | | | | |
|------------------------|------------|------|---------------|---------|------------|--------|------------|-------------------------------|------------------------|----|------|----|----|-----------------------|
| Permit Id | Issue Date | Type | Description | Amount | Insp Date | % Comp | Date Comp | Comments | Date | Id | Type | Is | Cd | Purpost/Result |
| 16-3027 | 10-27-2016 | 804 | Addn Alt-Res | 800,000 | 03-12-2018 | 100 | 06-30-2018 | Addition (new Master Bedroom | 06-12-2020 | WD | | | 25 | NO TRESPASSING |
| 16-2802 | 10-06-2016 | 804 | Addn Alt-Res | 265,000 | 05-08-2017 | 100 | 06-30-2017 | add 3 dormers, and 4 doors to | 03-12-2018 | SR | 01 | | 02 | Bldg Permit Completed |
| 201506450 | 09-29-2015 | NS | New Siding | 65,000 | 06-30-2016 | 100 | 06-30-2016 | RESIDE REPLACEMENT WIN | 06-14-2017 | SR | 01 | | 02 | Bldg Permit Completed |
| 82069 | 02-04-2005 | RE | Remodel | 34,799 | 06-02-2006 | 100 | 01-01-2006 | KITCHEN | 11-21-2016 | AL | 22 | | 22 | Change of Address |
| 56673 | 10-24-2001 | AD | Addition | 179,712 | 01-29-2002 | 100 | 01-01-2003 | | 06-06-2016 | SR | 02 | | 03 | Cycl Insp Comp |
| B26222 | 03-01-1984 | SP | Swimming Pool | 0 | 03-15-1985 | 100 | 12-31-1985 | OS POOL | 07-07-2015 | AL | 22 | | 22 | Change of Address |
| B23751 | 01-01-1982 | DW | Dwelling | 0 | 01-15-1983 | 100 | 12-31-1983 | OS 2 ST | 04-03-2015 | JR | 03 | | 03 | Cycl Insp Comp |

| LAND LINE VALUATION SECTION | | | | | | | | | | | | | | | | | |
|-----------------------------|----------|----------------|------|----|------------|------------------------|----------|---------|------------|-------|-------|------------------|-------|--------------------|------------|------------|-----------|
| B | Use Code | Description | Zone | LA | Land Units | Unit Price | Size Adj | AC Disc | Site Index | Cond. | Nbhd. | Nbhd. Adj | Notes | Location Adjustmen | Adj Unit P | Land Value | |
| 1 | 1010 | Single Fam M-0 | RF-1 | 3 | 1.000 AC | 176,344.00 | 1.00000 | 1.0000 | 5 | 1.00 | WF14 | 28.000 | | 1.0000 | 4,937,632 | 4,937,600 | |
| 1 | 1010 | Single Fam M-0 | RF-1 | 3 | 0.810 AC | 14,250.00 | 1.00000 | 1.0000 | 0 | 1.00 | WF14 | 28.000 | | 1.0000 | 399,000 | 323,200 | |
| Total Card Land Units | | | | | 1.81 AC | Parcel Total Land Area | | | | | 1.81 | Total Land Value | | | | | 5,260,800 |

| CONSTRUCTION DETAIL | | | CONSTRUCTION DETAIL (CONTINUED) | | |
|---------------------|----|----------------|--------------------------------------|----|-------------|
| Element | Cd | Description | Element | Cd | Description |
| Style | 07 | Modern/Contemp | | | |
| Model | 01 | Residential | | | |
| Grade: | X+ | Exceptional PI | | | |
| Stories | 2 | 2 Stories | | | |
| Exterior Wall 1 | 16 | Stucco on Wood | | | |
| Exterior Wall 2 | | | | | |
| RooF Structure | 03 | Gable/Hip | | | |
| RooF Cover | 08 | Clay Tile | | | |
| Interior Wall 1 | 03 | Plastered | | | |
| Interior Wall 2 | 04 | Plywood Panel | | | |
| Interior Floor 1 | 14 | Carpet | | | |
| Interior Floor 2 | 12 | Hardwood | | | |
| Heat Fuel | 02 | Oil | | | |
| Heat Type | 04 | Hot Air | | | |
| AC Type | 03 | Central | | | |
| Bedrooms | 06 | 6 Bedrooms | | | |
| Full Baths | 6 | | | | |
| Half Baths | 1 | | | | |
| Extra Fixtures | | | | | |
| Total Rooms | 11 | 11 Rooms | | | |
| Bath Style | | | | | |
| Kitchen Style | | | | | |
| Occupancy | | | | | |
| UsrflD 105 | | | | | |
| Accessory Apt | | | | | |
| Foundation Alt | 01 | Poured Conc. | | | |
| Rms Prts | | | | | |
| Bath Split | 61 | 6 Full-1 Half | | | |
| | | | CONDO DATA | | |
| | | | Parcel Id | C | Ownr 0.0 |
| | | | Adjust Type Code Description Factor% | | |
| | | | Condo Flr | | |
| | | | Condo Unit | | |
| | | | COST / MARKET VALUATION | | |
| | | | Building Value New | | 3,143,907 |
| | | | Year Built | | 1982 |
| | | | Effective Year Built | | 2017 |
| | | | Depreciation Code | | E |
| | | | Remodel Rating | | |
| | | | Year Remodeled | | |
| | | | Depreciation % | | 2 |
| | | | Functional Obsol | | 0 |
| | | | External Obsol | | 0 |
| | | | Trend Factor | | 1 |
| | | | Condition | | |
| | | | Condition % | | |
| | | | Percent Good | | 98 |
| | | | RCNLD | | 3,092,000 |
| | | | Dep % Ovr | | |
| | | | Dep Ovr Comment | | |
| | | | Misc Imp Ovr | | |
| | | | Misc Imp Ovr Comment | | |
| | | | Cost to Cure Ovr | | |
| | | | Cost to Cure Ovr Comment | | |

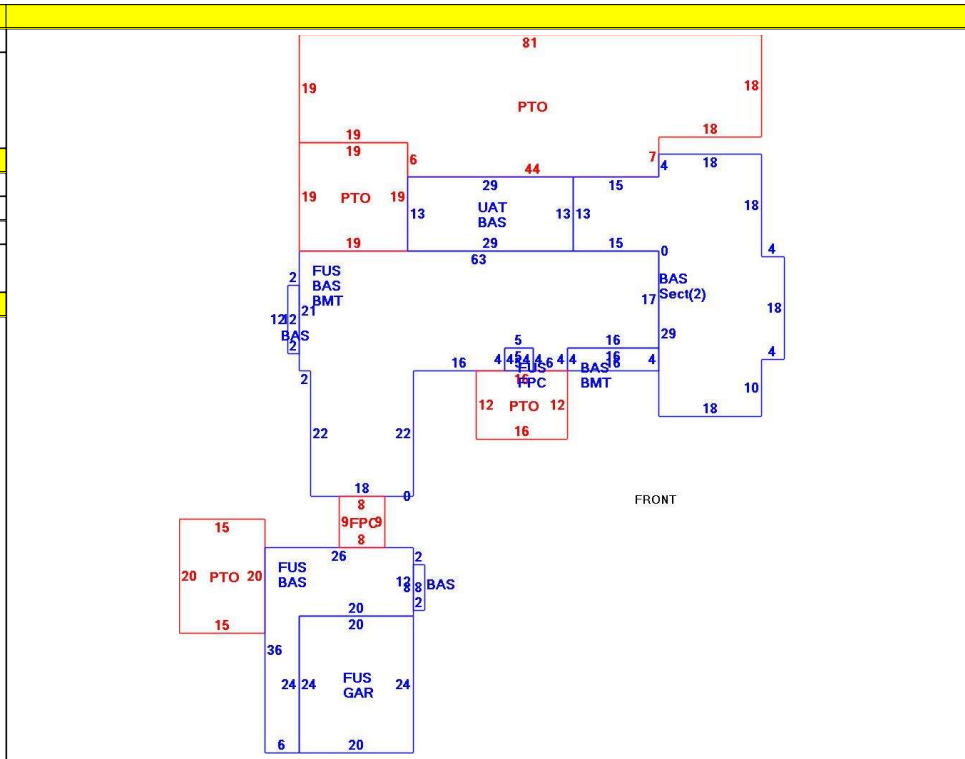

OB - OUTBUILDING & YARD ITEMS(L) / XF - BUILDING EXTRA FEATURES(B)

| Code | Description | L/B | Units | Unit Price | Yr Blt | Cond. Cd | % Gd | Grade | Grade Adj. | Appr. Value |
|------|-----------------|-----|-------|------------|--------|----------|------|-------|------------|-------------|
| FPL2 | Fireplace 1.5 s | B | 3 | 6000.00 | 2019 | | 98 | | 0.00 | 17,600 |
| SPL3 | Pool Gunite | L | 640 | 75.00 | 1984 | | 30 | 00 | 1.00 | 15,200 |
| DKHD | Dock-Heavy | L | 1 | 205000.0 | 1985 | | 32 | | 0.00 | 65,600 |
| WDC | Wood Decking | L | 120 | 20.00 | 2008 | | 78 | | 0.00 | 3,000 |
| PAT2 | Patio-Good | L | 192 | 9.94 | 2008 | | 89 | | 0.00 | 1,900 |
| GAR | Attached Gara | B | 480 | 40.00 | 2019 | | 98 | | 0.00 | 17,700 |
| BMT | Basement-Unfi | B | 1,701 | 26.01 | 2019 | | 98 | | 0.00 | 38,300 |
| PATC | Conc Pavers | L | 361 | 15.46 | 2008 | | 89 | | 0.00 | 4,900 |
| PATF | Flagstone Pav | L | 300 | 30.00 | 2008 | | 89 | | 0.00 | 8,000 |
| FOPC | Open Prch-roo | B | 92 | 55.00 | 2019 | | 98 | | 0.00 | 4,300 |

BUILDING SUB-AREA SUMMARY SECTION

| Code | Description | Living Area | Floor Area | Eff Area | Unit Cost | Undeprec Value |
|----------------------------|------------------------|-------------|------------|----------|-----------|----------------|
| BAS | First Floor | 2,572 | 2,572 | 2,572 | 499.35 | 1,284,328 |
| BMT | Basement Area | 0 | 1,699 | 0 | 0.00 | 0 |
| FPC | Open Porch Conc. Floor | 0 | 92 | 0 | 0.00 | 0 |
| FUS | Upper Story | 2,591 | 2,591 | 2,591 | 499.35 | 1,293,816 |
| GAR | Attached Garage | 0 | 480 | 0 | 0.00 | 0 |
| PTO | Patio | 0 | 2,638 | 0 | 0.00 | 0 |
| UAT | Attic, Unfinished | 0 | 377 | 38 | 50.33 | 18,975 |
| Ttl Gross Liv / Lease Area | | 5,163 | 10,449 | 5,201 | | 2,597,119 |



| CURRENT OWNER | | TOPO | UTILITIES | STRT / ROAD | LOCATION | CURRENT ASSESSMENT | | | | 801 FY2024 BARNSTABLE, MA VISION |
|---|--|--|----------------|-------------|--|--------------------|-------|-----------|-----------|--|
| MARTIGNETTI, TERESA C/O MARTIGNETTI, CARL J 500 JOHN HANCOCK ROAD TAUNTON MA 02780 | | 1 Level | 2 Public Water | 1 Paved | 7 Waterfront | Description | Code | Assessed | Assessed | |
| | | | 6 Septic | | 1 Excel View | RESIDNTL | 1010 | 3,327,400 | 3,327,400 | |
| SUPPLEMENTAL DATA | | | | | | RES LAND | 1010 | 5,260,800 | 5,260,800 | |
| | | Alt Prcl ID Split Zonin BID Parcel ResExpt Q #DL 1 LOT 2 #DL 2 GIS ID F_950604_2687543 | | | Plan Ref. 329/38 Land Ct# #SR Life Estate PP STATU Assoc Pid# | | Total | | 8,588,200 | 8,588,200 |

| RECORD OF OWNERSHIP | | BK-VOL/PAGE | SALE DATE | Q/U | V/I | SALE PRIC | VC | PREVIOUS ASSESSMENTS (HISTORY) | | | | | |
|---------------------|--|-------------|-----------|-----|-----|-----------|----|--------------------------------|------|-----------|-------|------|-----------|
| | | | | | | | | Year | Code | Assessed | Year | Code | Assessed |
| | | | | | | | | 2023 | 1010 | 2,571,600 | 2022 | 1010 | 2,384,200 |
| | | | | | | | | | 1010 | 4,812,000 | | 1010 | 4,560,300 |
| | | | | | | | | | | | 2021 | 1010 | 1,895,900 |
| | | | | | | | | | | | | 1010 | 4,299,700 |
| | | | | | | | | | | | | 1010 | 157,400 |
| | | | | | | | | Total | | 7,383,600 | Total | | 6,944,500 |
| | | | | | | | | Total | | | Total | | 6,353,000 |

| EXEMPTIONS | | | OTHER ASSESSMENTS | | | | APPRAISED VALUE SUMMARY | | | | | |
|------------|------|-------------|-------------------|------|-------------|--------|-------------------------|----------|---|--|-----------|--|
| Year | Code | Description | Amount | Code | Description | Number | Amount | Comm Int | This signature acknowledges a visit by a Data Collector or Assessor | | | |
| | | | | | | | | | APPRAISED VALUE SUMMARY | | | |
| Total | | | | | | | | | Appraised Bldg. Value (Card) | | 3,092,000 | |
| | | | | | | | | | Appraised Xf (B) Value (Bldg) | | 77,900 | |
| | | | | | | | | | Appraised Ob (B) Value (Bldg) | | 157,500 | |
| | | | | | | | | | Appraised Land Value (Bldg) | | 5,260,800 | |
| | | | | | | | | | Special Land Value | | 0 | |
| | | | | | | | | | Total Appraised Parcel Value | | 8,588,200 | |
| | | | | | | | | | Valuation Method | | C | |
| | | | | | | | | | Total Appraised Parcel Value | | 8,588,200 | |

| BUILDING PERMIT RECORD | | | | | | | | VISIT / CHANGE HISTORY | | | | | | |
|------------------------|------------|------|-------------|--------|-----------|--------|-----------|------------------------|------|----|------|----|----|----------------|
| Permit Id | Issue Date | Type | Description | Amount | Insp Date | % Comp | Date Comp | Comments | Date | Id | Type | Is | Cd | Purpost/Result |
| | | | | | | | | | | | | | | |

| LAND LINE VALUATION SECTION | | | | | | | | | | | | | | | | |
|-----------------------------|----------|-------------|------|----|------------------------|------------|----------|---------|------------|------------------|-------|-----------|-------|--------------------|------------|------------|
| B | Use Code | Description | Zone | LA | Land Units | Unit Price | Size Adj | AC Disc | Site Index | Cond. | Nbhd. | Nbhd. Adj | Notes | Location Adjustmen | Adj Unit P | Land Value |
| | | | | | | | | | | | | | | | | |
| Total Card Land Units | | | | | Parcel Total Land Area | | | | | Total Land Value | | | | | | |

| CONSTRUCTION DETAIL | | | | | | CONSTRUCTION DETAIL (CONTINUED) | | | | | |
|--|-----------------|----------------|------------|------------|-----------|---------------------------------|------|-------------|------------|-------------|-----|
| Element | Cd | Description | | | | Element | Cd | Description | | | |
| Style | 07 | Modern/Contemp | | | | | | | | | |
| Model | 01 | Residential | | | | | | | | | |
| Grade: | X+ | Exceptional PI | | | | | | | | | |
| Stories | 2 | 2 Stories | | | | | | | | | |
| Exterior Wall 1 | 16 | Stucco on Wood | | | | CONDO DATA | | | | | |
| Exterior Wall 2 | | | | | | Parcel Id | | C | | Owne | 0.0 |
| Roof Structure | 03 | Gable/Hip | | | | | | | B | | S |
| Roof Cover | 08 | Clay Tile | | | | Adjust Type | Code | Description | | Factor% | |
| Interior Wall 1 | 03 | Plastered | | | | Condo Flr | | | | | |
| Interior Wall 2 | 04 | Plywood Panel | | | | Condo Unit | | | | | |
| Interior Floor 1 | 14 | Carpet | | | | COST / MARKET VALUATION | | | | | |
| Interior Floor 2 | 12 | Hardwood | | | | Building Value New | | | | | |
| Heat Fuel | 02 | Oil | | | | Year Built | | | | | |
| Heat Type | 04 | Hot Air | | | | Effective Year Built | | | | | |
| AC Type | 03 | Central | | | | Depreciation Code | | | | | |
| Bedrooms | 06 | 6 Bedrooms | | | | Remodel Rating | | | | | |
| Full Baths | 6 | | | | | Year Remodeled | | | | | |
| Half Baths | 1 | | | | | Depreciation % | | | | | |
| Extra Fixtures | | | | | | Functional Obsol | | | | | |
| Total Rooms | 11 | 11 Rooms | | | | External Obsol | | | | | |
| Bath Style | | | | | | Trend Factor | | | | | |
| Kitchen Style | | | | | | Condition | | | | | |
| Occupancy | | | | | | Condition % | | | | | |
| Usrflid 105 | | | | | | Percent Good | | | | | |
| Accessory Apt | | | | | | RCNLD | | | | | |
| Foundation Alt | 01 | Poured Conc. | | | | Dep % Ovr | | | | | |
| Rms Prts | | | | | | Dep Ovr Comment | | | | | |
| Bath Split | 61 | 6 Full-1 Half | | | | Misc Imp Ovr | | | | | |
| | | | | | | Misc Imp Ovr Comment | | | | | |
| | | | | | | Cost to Cure Ovr | | | | | |
| | | | | | | Cost to Cure Ovr Comment | | | | | |
| OB - OUTBUILDING & YARD ITEMS(L) / XF - BUILDING EXTRA FEATURES(B) | | | | | | | | | | | |
| Code | Description | L/B | Units | Unit Price | Yr Blt | Cond. Cd | % Gd | Grade | Grade Adj. | Appr. Value | |
| SHD2 | Shed w/Elec | L | 192 | 26.00 | 2008 | | 78 | | 0.00 | 3,900 | |
| STRS | Stairs to Water | L | 45 | 122.52 | 1985 | | 32 | B+ | 1.40 | 2,500 | |
| SPH2 | Pool Heater 50 | L | 1 | 3081.00 | 2000 | | 62 | | 0.00 | 1,900 | |
| FNP1 | FENCE CHAI | L | 189 | 15.90 | 1984 | | 30 | B+ | 1.40 | 1,300 | |
| FNG1 | Gate 4'x3'w | L | 1 | 301.53 | 1984 | | 30 | B+ | 1.40 | 100 | |
| PAT1 | Patio- Average | L | 1,604 | 5.89 | 1984 | | 65 | | 0.00 | 5,200 | |
| PATF | Flagstone Pav | L | 1,785 | 30.00 | 2018 | | 99 | | 0.00 | 44,000 | |
| BUILDING SUB-AREA SUMMARY SECTION | | | | | | | | | | | |
| Code | Description | Living Area | Floor Area | Eff Area | Unit Cost | Undeprec Value | | | | | |
| | | | | | | | | | | | |
| Ttl Gross Liv / Lease Area | | | | | | | | | | | |

| CURRENT OWNER | | TOPO | | UTILITIES | | STRT / ROAD | | LOCATION | | CURRENT ASSESSMENT | | | | 801 FY2024 BARNSTABLE, MA VISION | | | | | | |
|---|------------|-------------------|---------------|-------------------|------------------|---------------|------------------------|---|------------|------------------------|-------|--|------------------|--|-----------------------|-----------------------|--------------|------------------------|------------------------|-----------|
| MARTIGNETTI, TERESA C/O MARTIGNETTI, CARL J 500 JOHN HANCOCK ROAD TAUNTON MA 02780 | | 1 | Level | 2 | Public Water | 1 | Paved | 7 | Waterfront | Description | Code | Assessed | Assessed | | | RESIDENTL RES LAND | 1010 1010 | 3,327,400 5,260,800 | 3,327,400 5,260,800 | |
| | | 6 | Septic | | | | | | | | | | | | | | | | | |
| | | SUPPLEMENTAL DATA | | | | | | | | | | | | | | | | | | |
| Alt Prcl ID | | | | | Plan Ref. 329/38 | | | | | Total | | 8,588,200 | 8,588,200 | | | | | | | |
| Split Zonin | | | | | Land Ct# | | | | | | | | | | | | | | | |
| BID Parcel | | | | | #SR | | | | | | | | | | | | | | | |
| ResExpt Q | | | | | Life Estate | | | | | | | | | | | | | | | |
| #DL 1 LOT 2 | | | | | PP STATU | | | | | | | | | | | | | | | |
| #DL 2 | | | | | Assoc Pid# | | | | | | | | | | | | | | | |
| GIS ID F_950604_2687543 | | | | | | | | | | | | | | | | | | | | |
| RECORD OF OWNERSHIP | | BK-VOL/PAGE | | SALE DATE | | Q/U | | V/I | | SALE PRIC | | VC | | PREVIOUS ASSESSMENTS (HISTORY) | | | | | | |
| MARTIGNETTI, TERESA MARTIGNETTI, FERDINAND & TERESA BIRMINGHAM, PAUL J | | 14181 | 0256 | 08-29-2001 | | U | I | | | 0 | 1A | Year | Code | Assessed | Year | Code | Assessed | Year | Code | Assessed |
| | | 10008 | 0270 | 01-15-1996 | | Q | I | 1,775,000 | | 00 | | 2023 | 1010 | 2,571,600 | 2022 | 1010 | 2,384,200 | 2021 | 1010 | 1,895,900 |
| | | 2936 | 0216 | 06-18-1979 | | U | | 0 | | | | | 1010 | 4,812,000 | | 1010 | 4,560,300 | | 1010 | 4,299,700 |
| | | Total | | | | | | | | | | Total | | Total | | Total | | Total | | |
| | | 0.00 | | | | | | | | | | 7,383,600 | | 6,944,500 | | 6,353,000 | | | | |
| EXEMPTIONS | | | | OTHER ASSESSMENTS | | | | This signature acknowledges a visit by a Data Collector or Assessor | | | | | | | | | | | | |
| Year | Code | Description | | Amount | | Code | Description | Number | Amount | Comm Int | | | | | | | | | | |
| Total | | | | 0.00 | | | | | | | | APPRAISED VALUE SUMMARY | | | | | | | | |
| | | | | | | | | | | | | Appraised Bldg. Value (Card) 3,092,000 | | | | | | | | |
| | | | | | | | | | | | | Appraised Xf (B) Value (Bldg) 77,900 | | | | | | | | |
| | | | | | | | | | | | | Appraised Ob (B) Value (Bldg) 157,500 | | | | | | | | |
| | | | | | | | | | | | | Appraised Land Value (Bldg) 5,260,800 | | | | | | | | |
| | | | | | | | | | | | | Special Land Value 0 | | | | | | | | |
| | | | | | | | | | | | | Total Appraised Parcel Value 8,588,200 | | | | | | | | |
| | | | | | | | | | | | | Valuation Method C | | | | | | | | |
| | | | | | | | | | | | | Total Appraised Parcel Value 8,588,200 | | | | | | | | |
| BUILDING PERMIT RECORD | | | | | | | | | | VISIT / CHANGE HISTORY | | | | | | | | | | |
| Permit Id | Issue Date | Type | Description | Amount | Insp Date | % Comp | Date Comp | Comments | | Date | Id | Type | Is | Cd | Purpost/Result | | | | | |
| 16-3027 | 10-27-2016 | 804 | Addn Alt-Res | 800,000 | 03-12-2018 | 100 | 06-30-2018 | Addition (new Master Bedroom | | 06-12-2020 | WD | | | 25 | NO TRESPASSING | | | | | |
| 16-2802 | 10-06-2016 | 804 | Addn Alt-Res | 265,000 | 05-08-2017 | 100 | 06-30-2017 | add 3 dormers, and 4 doors to | | 03-12-2018 | SR | 01 | | 02 | Bldg Permit Completed | | | | | |
| 201506450 | 09-29-2015 | NS | New Siding | 65,000 | 06-30-2016 | 100 | 06-30-2016 | RESIDE REPLACEMENT WIN | | 06-14-2017 | SR | 01 | | 02 | Bldg Permit Completed | | | | | |
| 82069 | 02-04-2005 | RE | Remodel | 34,799 | 06-02-2006 | 100 | 01-01-2006 | KITCHEN | | 11-21-2016 | AL | 22 | | 22 | Change of Address | | | | | |
| 56673 | 10-24-2001 | AD | Addition | 179,712 | 01-29-2002 | 100 | 01-01-2003 | | | 06-06-2016 | SR | 02 | | 03 | Cycl Insp Comp | | | | | |
| B26222 | 03-01-1984 | SP | Swimming Pool | 0 | 03-15-1985 | 100 | 12-31-1985 | OS POOL | | 07-07-2015 | AL | 22 | | 22 | Change of Address | | | | | |
| B23751 | 01-01-1982 | DW | Dwelling | 0 | 01-15-1983 | 100 | 12-31-1983 | OS 2 ST | | 04-03-2015 | JR | 03 | | 03 | Cycl Insp Comp | | | | | |
| LAND LINE VALUATION SECTION | | | | | | | | | | | | | | | | | | | | |
| B | Use Code | Description | Zone | LA | Land Units | Unit Price | Size Adj | AC Disc | Site Index | Cond. | Nbhd. | Nbhd. Adj | Notes | | | Location Adjustmen | | Adj Unit P | Land Value | |
| 1 | 1010 | Single Fam M-0 | RF-1 | 3 | 1.000 | AC 176,344.00 | 1.00000 | 1.0000 | 5 | 1.00 | WF14 | 28.000 | | | | 1.0000 | 4,937,632 | 4,937,600 | | |
| 1 | 1010 | Single Fam M-0 | RF-1 | 3 | 0.810 | AC 14,250.00 | 1.00000 | 1.0000 | 0 | 1.00 | WF14 | 28.000 | | | | 1.0000 | 399,000 | 323,200 | | |
| Total Card Land Units | | | | | 1.81 | AC | Parcel Total Land Area | | | | | 1.81 | Total Land Value | | | | | 5,260,800 | | |

CONSTRUCTION DETAIL CONSTRUCTION DETAIL (CONTINUED)

| Element | Cd | Description | Element | Cd | Description |
|------------------|----|----------------|---------|----|-------------|
| Style | 07 | Modern/Contemp | | | |
| Model | 01 | Residential | | | |
| Grade: | X+ | Exceptional PI | | | |
| Stories | 1 | 1 Story | | | |
| Exterior Wall 1 | 16 | Stucco on Wood | | | |
| Exterior Wall 2 | | | | | |
| RooF Structure | 03 | Gable/Hip | | | |
| RooF Cover | 08 | Clay Tile | | | |
| Interior Wall 1 | 03 | Plastered | | | |
| Interior Wall 2 | 04 | Plywood Panel | | | |
| Interior Floor 1 | 14 | Carpet | | | |
| Interior Floor 2 | 12 | Hardwood | | | |
| Heat Fuel | 02 | Oil | | | |
| Heat Type | 04 | Hot Air | | | |
| AC Type | 03 | Central | | | |
| Bedrooms | 01 | 1 Bedroom | | | |
| Full Baths | 0 | | | | |
| Half Baths | 0 | | | | |
| Extra Fixtures | | | | | |
| Total Rooms | | | | | |
| Bath Style | | | | | |
| Kitchen Style | | | | | |
| Occupancy | | | | | |
| UsrflD 105 | | | | | |
| Accessory Apt | | | | | |
| Foundation Alt | | | | | |
| Rms Prts | | | | | |
| Bath Split | | | | | |

| CONDO DATA | | | | |
|-------------|------|-------------|---------|----------|
| Parcel Id | | C | | Ownr 0.0 |
| | | | B | S |
| Adjust Type | Code | Description | Factor% | |
| Condo Flr | | | | |
| Condo Unit | | | | |

| COST / MARKET VALUATION | | | |
|--------------------------|--|-----------|--|
| Building Value New | | 3,143,907 | |
| Year Built | | 2016 | |
| Effective Year Built | | 2019 | |
| Depreciation Code | | E | |
| Remodel Rating | | | |
| Year Remodeled | | | |
| Depreciation % | | 0 | |
| Functional Obsol | | | |
| External Obsol | | | |
| Trend Factor | | 1 | |
| Condition | | | |
| Condition % | | | |
| Percent Good | | 100 | |
| RCNLD | | 3,092,000 | |
| Dep % Ovr | | | |
| Dep Ovr Comment | | | |
| Misc Imp Ovr | | | |
| Misc Imp Ovr Comment | | | |
| Cost to Cure Ovr | | | |
| Cost to Cure Ovr Comment | | | |

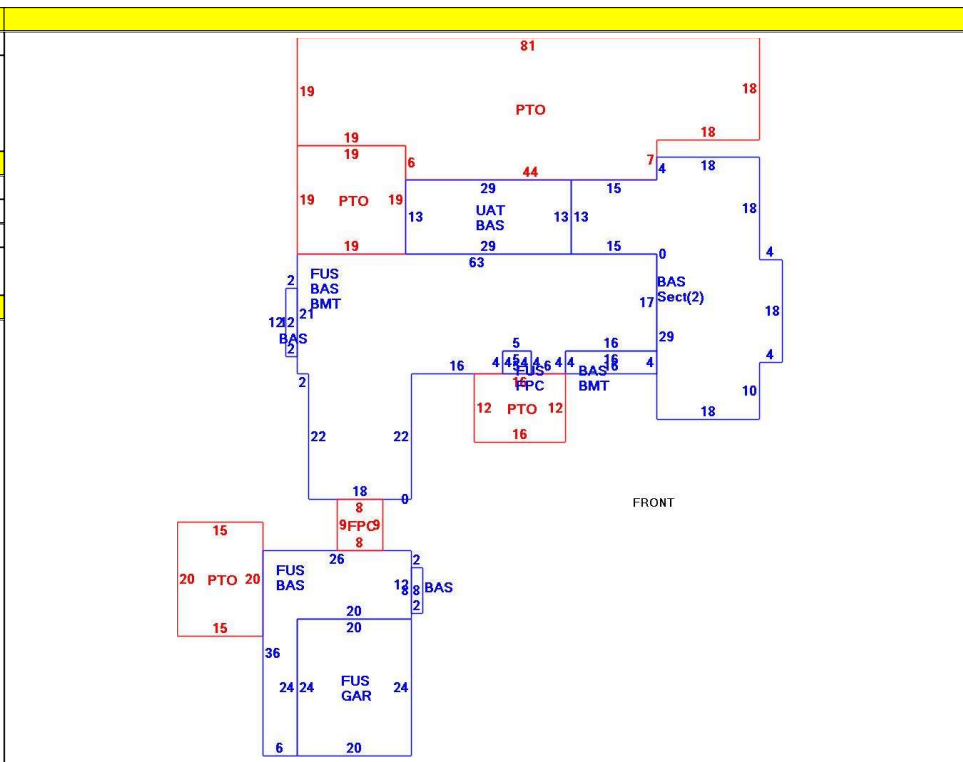

OB - OUTBUILDING & YARD ITEMS(L) / XF - BUILDING EXTRA FEATURES(B)

| Code | Description | L/B | Units | Unit Price | Yr Blt | Cond. Cd | % Gd | Grade | Grade Adj. | Appr. Value |
|------|-------------|-----|-------|------------|--------|----------|------|-------|------------|-------------|
| | | | | | | | | | | |
| | | | | | | | | | | |
| | | | | | | | | | | |
| | | | | | | | | | | |
| | | | | | | | | | | |
| | | | | | | | | | | |
| | | | | | | | | | | |
| | | | | | | | | | | |
| | | | | | | | | | | |
| | | | | | | | | | | |
| | | | | | | | | | | |

BUILDING SUB-AREA SUMMARY SECTION

| Code | Description | Living Area | Floor Area | Eff Area | Unit Cost | Undeprec Value |
|----------------------------|-------------|-------------|------------|----------|-----------|----------------|
| BAS | First Floor | 1,095 | 1,095 | 1,095 | 499.35 | 546,788 |
| Ttl Gross Liv / Lease Area | | 1,095 | 1,095 | 1,095 | | 546,788 |

