

CURRENT OWNER		TOPO	UTILITIES	STRT / ROAD	LOCATION	CURRENT ASSESSMENT			
MAZHEIKA, ANDREI & SVIATLANA  128 WINDING COVE ROAD  MARSTONS MIL MA 02648		1 Level	2 Public Water			Description RESIDENTL RES LAND	Code 1010 1010	Assessed 608,500 237,900	Assessed 608,500 237,900
			4 Gas	1 Paved					
			6 Septic						
SUPPLEMENTAL DATA									
Alt Prcl ID		Split Zonin		Plan Ref. 272/29-F2					
BID Parcel		ResExpt Q YES:		Land Ct#					
#DL 1 LOT 91		#DL 2		Life Estate					
GIS ID F_951614_2698052		Assoc Pid#							
						Total	846,400	846,400	

801  
 FY2024  
 BARNSTABLE, MA  
**VISION**

RECORD OF OWNERSHIP		BK-VOL/PAGE	SALE DATE	Q/U	V/I	SALE PRIC	VC	PREVIOUS ASSESSMENTS (HISTORY)					
MAZHEIKA, ANDREI & SVIATLANA		32025 0252	05-16-2019	Q	I	575,000	00	Year	Code	Assessed	Year	Code	Assessed
ELDRIDGE, NANCY R TR		32025 0247	02-20-2019	U	I	0	1F	2023	1010	539,400	2022	1010	457,700
ROCKETT, ANNE E TR ANNE E ROCKET		23521 0069	03-12-2009	U	I	1	1F		1010	216,300		1010	148,800
ROCKETT, ANNE E		18828 0328	07-15-2004	U	I	10	1A					1010	10,000
ROCKETT, ANNE E TR		13139 0167	07-21-2000	U	I	1	1A						
						Total	755,700	Total	606,500	Total	545,600		

EXEMPTIONS			OTHER ASSESSMENTS					
Year	Code	Description	Amount	Code	Description	Number	Amount	Comm Int
2022	5C	RESIDENTIAL EXEMPTION	0.00					
Total			0.00					

This signature acknowledges a visit by a Data Collector or Assessor

ASSESSING NEIGHBORHOOD			
Nbhd	Nbhd Name	B	Tracing
0108			MARSTM

APPRAISED VALUE SUMMARY	
Appraised Bldg. Value (Card)	546,300
Appraised Xf (B) Value (Bldg)	52,200
Appraised Ob (B) Value (Bldg)	10,000
Appraised Land Value (Bldg)	237,900
Special Land Value	0
Total Appraised Parcel Value	846,400
Valuation Method	C
Total Appraised Parcel Value	846,400

NOTES								

BUILDING PERMIT RECORD									VISIT / CHANGE HISTORY					
Permit Id	Issue Date	Type	Description	Amount	Insp Date	% Comp	Date Comp	Comments	Date	Id	Type	Is	Cd	Purpost/Result
20-95	01-13-2020	833	Shd-Res-under	0	08-19-2020	100	06-30-2020	new shed 12 x 16	01-19-2022	AS	03		16	In Office Review
B30311	12-01-1986	DW	Dwelling	160,000	01-15-1988	100	12-31-1988	MM 11/2 S	08-19-2020	RB	02		02	Bldg Permit Completed
									06-01-2020	DM			FR	Field Review
									02-19-2020	SAF			20	Sale Review
									01-09-2020	CK	03		16	In Office Review
									05-15-2019	SR	02		03	Cycl Insp Comp
									01-14-2019	RB	22		22	Change of Address

LAND LINE VALUATION SECTION																	
B	Use Code	Description	Zone	LA	Land Units	Unit Price	Size Adj	AC Disc	Site Index	Cond.	Nbhd.	Nbhd. Adj	Notes	Location Adjustmen	Adj Unit P	Land Value	
1	1010	Single Fam M-0	RF	3	0.700	AC	176,344.00	1.37675	1.0000	5	1.00	0107	1.400		1.0000	339,903.0	237,900
Total Card Land Units					0.70	AC	Parcel Total Land Area					0.70	Total Land Value			237,900	

CONSTRUCTION DETAIL			CONSTRUCTION DETAIL (CONTINUED)		
Element	Cd	Description	Element	Cd	Description
Style	04	Cape Cod			
Model	01	Residential			
Grade:	C+	Average Plus			
Stories	1.75	1 3/4 Stories			
Exterior Wall 1	14	Wood Shingle			
Exterior Wall 2	11	Clapboard			
Roof Structure	03	Gable/Hip			
Roof Cover	03	Asph/F Gls/Cmp			
Interior Wall 1	05	Drywall			
Interior Wall 2					
Interior Floor 1	14	Carpet			
Interior Floor 2	12	Hardwood			
Heat Fuel	03	Gas			
Heat Type	04	Hot Air			
AC Type	03	Central			
Bedrooms	03	3 Bedrooms			
Full Baths	2				
Half Baths	1				
Extra Fixtures					
Total Rooms	8				
Bath Style					
Kitchen Style					
Occupancy					
Usrflid 105					
Accessory Apt					
Foundation Alt	01	Poured Conc.			
Rms Prts					
Bath Split	21	2 Full-1 Half			

CONDO DATA				
Parcel Id		C		Owne 0.0
			B	S
Adjust Type	Code	Description	Factor%	
Condo Flr				
Condo Unit				

COST / MARKET VALUATION		
Building Value New		650,380
Year Built		1986
Effective Year Built		1999
Depreciation Code		A
Remodel Rating		
Year Remodeled		
Depreciation %		16
Functional Obsol		0
External Obsol		0
Trend Factor		1
Condition		
Condition %		
Percent Good		84
RCNLD		546,300
Dep % Ovr		
Dep Ovr Comment		
Misc Imp Ovr		
Misc Imp Ovr Comment		
Cost to Cure Ovr		
Cost to Cure Ovr Comment		

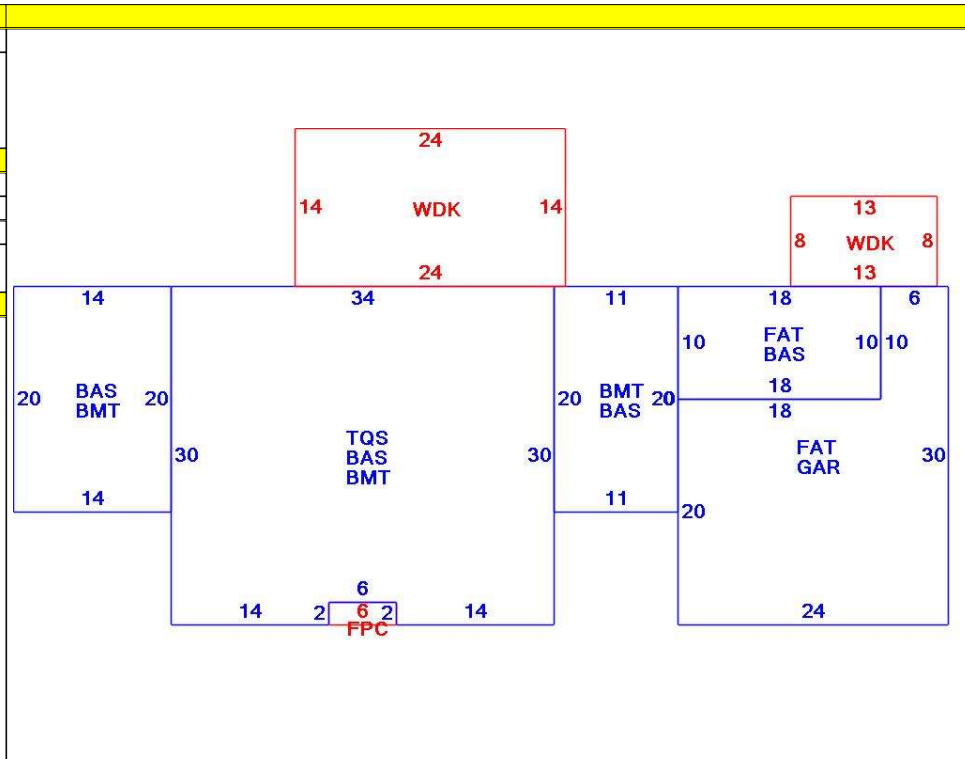

OB - OUTBUILDING & YARD ITEMS(L) / XF - BUILDING EXTRA FEATURES(B)										
Code	Description	L/B	Units	Unit Price	Yr Blt	Cond. Cd	% Gd	Grade	Grade Adj.	Appr. Value
FPL2	Fireplace 1.5 s	B	1	6000.00	2001		84		0.00	5,000
WDC	Wood Decking	L	440	20.00	1999		60		0.00	5,000
FOPC	Open Prch-roo	B	12	55.00	2001		84		0.00	900
GAR	Attached Gara	B	540	40.00	2001		84		0.00	16,400
BMT	Basement-Unfi	B	1,508	26.01	2001		84		0.00	29,900
SHD2	Shed w/Elec	L	192	26.00	2020		100		0.00	5,000

BUILDING SUB-AREA SUMMARY SECTION						
Code	Description	Living Area	Floor Area	Eff Area	Unit Cost	Undeprec Value
BAS	First Floor	1,688	1,688	1,688	265.35	447,916
BMT	Basement Area	0	1,508	0	0.00	0
FAT	Attic, Finished	108	720	108	39.80	28,658
FPC	Open Porch Conc. Floor	0	12	0	0.00	0
GAR	Attached Garage	0	540	0	0.00	0
TQS	Three Quarter Story	655	1,008	655	172.43	173,806
WDK	Wood Deck	0	440	0	0.00	0
Ttl Gross Liv / Lease Area		2,451	5,916	2,451		650,380

