

| CURRENT OWNER | | TOPO | UTILITIES | STRT / ROAD | LOCATION | CURRENT ASSESSMENT | | | | | | |
|---|--|-------------------------|--------------|-------------|--------------|--------------------|-------|-------------------------------------|----------------------|--------------------------------|--------------------------------|--|
| MALCHIODI, DANIEL L & KAREN M T DANIEL MALCHIODI 2021 TRUST 153 WINDING COVE ROAD | | 2 | Above Street | 2 | Public Water | 1 | Paved | Description RESIDNTL RES LAND | Code 1010 1010 | Assessed 439,800 232,100 | Assessed 439,800 232,100 | |
| | | 4 | Gas | | | | | | | | | |
| | | 6 | Septic | | | | | | | | | |
| SUPPLEMENTAL DATA | | | | | | | | | | | | |
| MARSTONS MIL MA 02648 | | Alt Prcl ID | | | | Plan Ref. 272/29 | | Total 671,900 671,900 | | | | |
| | | Split Zonin | | | | Land Ct# | | | | | | |
| | | BID Parcel | | | | #SR | | | | | | |
| | | ResExpt Q YES: | | | | Life Estate | | | | | | |
| | | #DL 1 LOT 71 | | | | PP STATU | | | | | | |
| | | #DL 2 | | | | Assoc Pid# | | | | | | |
| | | GIS ID F_951964_2697847 | | | | | | | | | | |

801
 FY2024
 BARNSTABLE, MA

VISION

| RECORD OF OWNERSHIP | | BK-VOL/PAGE | SALE DATE | Q/U | V/I | SALE PRIC | VC | PREVIOUS ASSESSMENTS (HISTORY) | | | | | | | | |
|-----------------------------------|--|-------------|------------|-----|-----|-----------|----|--------------------------------|------|----------|---------|------|----------|---------|------|----------|
| MALCHIODI, DANIEL L & KAREN M TRS | | 34651 206 | 11-10-2021 | U | I | 1 | 1F | Year | Code | Assessed | Year | Code | Assessed | Year | Code | Assessed |
| MALCHIODI, DANIEL L & KAREN M | | 18017 0349 | 12-10-2003 | U | I | 0 | 1F | 2023 | 1010 | 383,100 | 2022 | 1010 | 330,600 | 2021 | 1010 | 267,600 |
| MALCHIODI, DANIEL L & KAREN M TRS | | 17308 0183 | 07-22-2003 | U | I | 0 | 1F | | 1010 | 211,000 | | 1010 | 145,100 | | 1010 | 147,400 |
| MALCHIODI, DANIEL L & KAREN M | | 15556 0319 | 09-05-2002 | U | I | 1 | 1F | | | | | | | | 1010 | 4,100 |
| MALCHIODI, KAREN M & DANIEL L | | 15556 0299 | 09-05-2002 | U | I | 1 | 1F | | | | | | | | | |
| Total | | | | | | | | 594,100 | | Total | 475,700 | | Total | 419,100 | | |

| EXEMPTIONS | | | | OTHER ASSESSMENTS | | | | This signature acknowledges a visit by a Data Collector or Assessor | | | | | | | | | | | | |
|------------|------|-----------------------|--------|-------------------|-------------|--------|--------|---|--|--|--|--|--|--|--|--|--|--|--|--|
| Year | Code | Description | Amount | Code | Description | Number | Amount | Comm Int | | | | | | | | | | | | |
| 2023 | 5C | RESIDENTIAL EXEMPTION | 0.00 | | | | | | | | | | | | | | | | | |
| Total | | | 0.00 | | | | | | | | | | | | | | | | | |

| ASSESSING NEIGHBORHOOD | | | | APPRAISED VALUE SUMMARY | | | | |
|------------------------|-----------|---|---------|-------------------------|--|--|--|--|
| Nbhd | Nbhd Name | B | Tracing | Batch | | | | |
| 0108 | | | MARSTM | | | | | |

| NOTES | | | | | | | | | | | | APPRAISED VALUE SUMMARY | | | |
|-------|--|--|--|--|--|--|--|--|--|--|--|-------------------------------|---------|--|--|
| | | | | | | | | | | | | Appraised Bldg. Value (Card) | 385,800 | | |
| | | | | | | | | | | | | Appraised Xf (B) Value (Bldg) | 49,900 | | |
| | | | | | | | | | | | | Appraised Ob (B) Value (Bldg) | 4,100 | | |
| | | | | | | | | | | | | Appraised Land Value (Bldg) | 232,100 | | |
| | | | | | | | | | | | | Special Land Value | 0 | | |
| | | | | | | | | | | | | Total Appraised Parcel Value | 671,900 | | |
| | | | | | | | | | | | | Valuation Method | C | | |
| | | | | | | | | | | | | Total Appraised Parcel Value | 671,900 | | |

| BUILDING PERMIT RECORD | | | | | | | | VISIT / CHANGE HISTORY | | | | | | | |
|------------------------|--------------------------|-----------|----------------------------|------------|------------|------------|------------|--|--|----------------------------|----------------------|----|----------------------------|--|--|
| Permit Id | Issue Date | Type | Description | Amount | Insp Date | % Comp | Date Comp | Comments | Date | Id | Type | Is | Cd | Purpost/Result | |
| EXPR-21-1 B21538 | 09-28-2021 08-01-1979 | 835 DW | Sid/Wind/Roof/ Dwelling | 4,799 0 | 01-15-1980 | 100 100 | 12-31-1980 | Air sealing , insulate bulkhead MM 1 STOR | 07-22-2022 06-01-2020 07-07-2016 10-05-2005 05-09-1999 | JO DM KM PT FS | 02 02 01 01 | | 16 FR 03 01 00 | In Office Review Field Review Cycl Insp Comp Meas/Est Meas/Listed-Interior Acces | |

| LAND LINE VALUATION SECTION | | | | | | | | | | | | | | | | | |
|-----------------------------|----------|----------------|------|----|------------|------------|------------------------|---------|------------|-------|-------|-----------|------------------|--------------------|------------|------------|---------|
| B | Use Code | Description | Zone | LA | Land Units | Unit Price | Size Adj | AC Disc | Site Index | Cond. | Nbhd. | Nbhd. Adj | Notes | Location Adjustmen | Adj Unit P | Land Value | |
| 1 | 1010 | Single Fam M-0 | RF | 3 | 0.610 AC | 176,344.00 | 1.54133 | 1.0000 | 5 | 1.00 | 0107 | 1.400 | | 1.0000 | 380,532.7 | 232,100 | |
| Total Card Land Units | | | | | 0.61 | AC | Parcel Total Land Area | | | | | 0.61 | Total Land Value | | | | 232,100 |

| CONSTRUCTION DETAIL | | | CONSTRUCTION DETAIL (CONTINUED) | | |
|---------------------|----|----------------|---------------------------------|----|-------------|
| Element | Cd | Description | Element | Cd | Description |
| Style | 01 | Ranch | | | |
| Model | 01 | Residential | | | |
| Grade: | C+ | Average Plus | | | |
| Stories | 1 | 1 Story | | | |
| Exterior Wall 1 | 11 | Clapboard | | | |
| Exterior Wall 2 | 14 | Wood Shingle | | | |
| Roof Structure | 03 | Gable/Hip | | | |
| Roof Cover | 03 | Asph/F Gls/Cmp | | | |
| Interior Wall 1 | 05 | Drywall | | | |
| Interior Wall 2 | | | | | |
| Interior Floor 1 | 14 | Carpet | | | |
| Interior Floor 2 | 12 | Hardwood | | | |
| Heat Fuel | 03 | Gas | | | |
| Heat Type | 05 | Hot Water | | | |
| AC Type | 03 | Central | | | |
| Bedrooms | 03 | 3 Bedrooms | | | |
| Full Baths | 2 | | | | |
| Half Baths | 0 | | | | |
| Extra Fixtures | | | | | |
| Total Rooms | 6 | 6 Rooms | | | |
| Bath Style | | | | | |
| Kitchen Style | | | | | |
| Occupancy | | | | | |
| Usrflid 105 | | | | | |
| Accessory Apt | | | | | |
| Foundation Alt | 01 | Poured Conc. | | | |
| Rms Prts | | | | | |
| Bath Split | 20 | 2 Full-0 Half | | | |

| CONDO DATA | | | |
|-------------|------|-------------|---------|
| Parcel Id | C | Owne | 0.0 |
| Adjust Type | Code | Description | Factor% |
| Condo Flr | | | |
| Condo Unit | | | |

| COST / MARKET VALUATION | |
|--------------------------|---------|
| Building Value New | 476,274 |
| Year Built | 1979 |
| Effective Year Built | 1995 |
| Depreciation Code | A |
| Remodel Rating | |
| Year Remodeled | |
| Depreciation % | 19 |
| Functional Obsol | 0 |
| External Obsol | 0 |
| Trend Factor | 1 |
| Condition | |
| Condition % | |
| Percent Good | 81 |
| RCNLD | 385,800 |
| Dep % Ovr | |
| Dep Ovr Comment | |
| Misc Imp Ovr | |
| Misc Imp Ovr Comment | |
| Cost to Cure Ovr | |
| Cost to Cure Ovr Comment | |

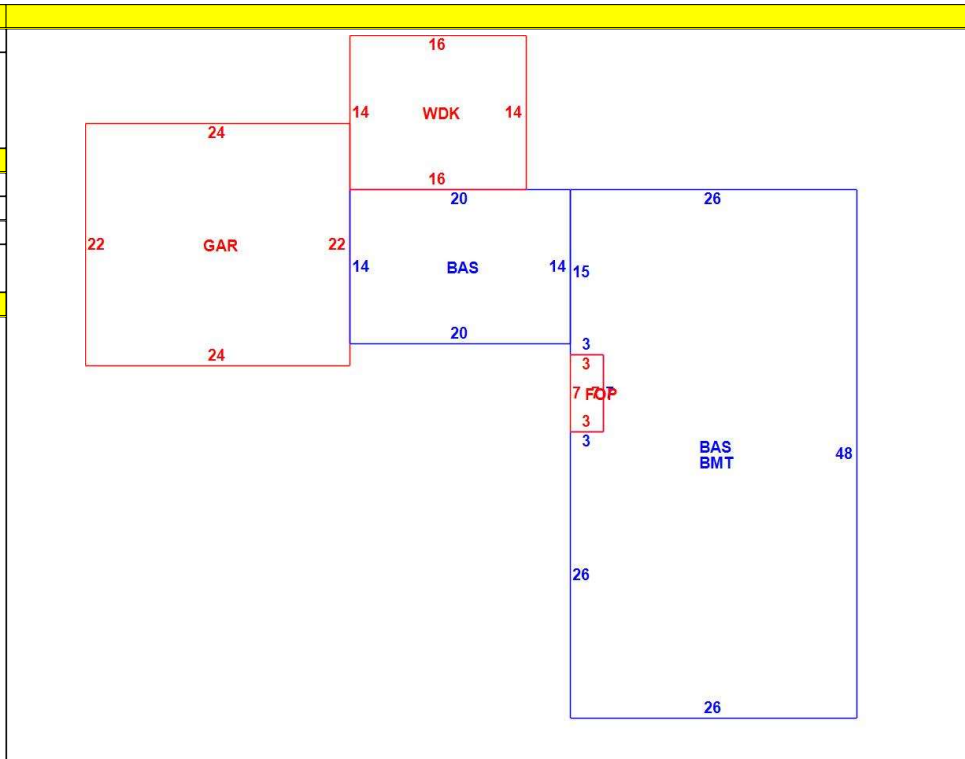

| OB - OUTBUILDING & YARD ITEMS(L) / XF - BUILDING EXTRA FEATURES(B) | | | | | | | | | | |
|--|-----------------|-----|-------|------------|--------|----------|------|-------|------------|-------------|
| Code | Description | L/B | Units | Unit Price | Yr Blt | Cond. Cd | % Gd | Grade | Grade Adj. | Appr. Value |
| FPL1 | Fireplace 1 sto | B | 2 | 5000.00 | 1997 | | 81 | | 0.00 | 8,100 |
| WDC | Deck comp w | L | 224 | 28.00 | 1998 | | 58 | | 0.00 | 4,100 |
| FOP | Open Porch-ro | B | 21 | 55.00 | 1997 | | 81 | | 0.00 | 1,500 |
| GAR | Attached Gara | B | 528 | 40.00 | 1997 | | 81 | | 0.00 | 15,600 |
| BMT | Basement-Unfi | B | 1,227 | 26.01 | 1997 | | 81 | | 0.00 | 24,700 |

| BUILDING SUB-AREA SUMMARY SECTION | | | | | | |
|-----------------------------------|-----------------|-------------|------------|----------|-----------|----------------|
| Code | Description | Living Area | Floor Area | Eff Area | Unit Cost | Undeprec Value |
| BAS | First Floor | 1,507 | 1,507 | 1,507 | 316.04 | 476,274 |
| BMT | Basement Area | 0 | 1,227 | 0 | 0.00 | 0 |
| FOP | Open Porch | 0 | 21 | 0 | 0.00 | 0 |
| GAR | Attached Garage | 0 | 528 | 0 | 0.00 | 0 |
| WDC | Wood Deck | 0 | 224 | 0 | 0.00 | 0 |
| Ttl Gross Liv / Lease Area | | 1,507 | 3,507 | 1,507 | | 476,274 |

