

CURRENT OWNER		TOPO	UTILITIES	STRT / ROAD	LOCATION	CURRENT ASSESSMENT			
ZHAUROV, YURIY & ZHAUROVA, IRE ZHAUROVA, LUBA 38 LARCRIDGE LN  ASHLAND MA 01721		2   Above Street	2   Public Water			Description RESIDENTL RES LAND	Code 1010 1010	Assessed 551,100 179,600	Assessed 551,100 179,600
		4   Gas	1   Paved						
		6   Septic							
SUPPLEMENTAL DATA									
Alt Prcl ID Split Zonin BID Parcel ResExpt Q INFO: #DL 1 LOT 27 #DL 2 GIS ID F_951085_2697051					Plan Ref. 337/1 Land Ct# #SR Life Estate PP STATU Assoc Pid#				
Total							730,700	730,700	

801  
 FY2024  
 BARNSTABLE, MA  
**VISION**

RECORD OF OWNERSHIP		BK-VOL/PAGE	SALE DATE	Q/U	V/I	SALE PRIC	VC	PREVIOUS ASSESSMENTS (HISTORY)					
ZHAUROV, YURIY & ZHAUROVA, IRENE	35399	029	09-30-2022	U	I	571,266	1A	Year	Code	Assessed	Year	Code	Assessed
TENIR LLC	35328	155	08-25-2022	Q	I	700,000	00	2023	1010	489,700	2022	1010	417,200
ALEXANDER, RAYMOND TR	35328	151	02-13-2022	U	I	0	1F		1010	177,500		1010	126,200
ALEXANDER, RAYMOND & GLORIA TRS	15767	0097	10-21-2002	U	I	1	1F					1010	4,600
ALEXANDER, RAYMOND R & GLORIA P	11801	0199	10-30-1998	Q	I	240,000	00	Total		667,200	Total		543,400
								Total		483,300	Total		483,300

EXEMPTIONS				OTHER ASSESSMENTS				This signature acknowledges a visit by a Data Collector or Assessor									
Year	Code	Description	Amount	Code	Description	Number	Amount	Comm	Int								
2023	N5C	NO RESIDENTIAL EXEMPTION	0.00														
Total			0.00														

ASSESSING NEIGHBORHOOD				APPRAISED VALUE SUMMARY					
Nbhd	Nbhd Name	B	Tracing	Batch					
0106			MARSTM						
NOTES								Appraised Bldg. Value (Card)	485,700
								Appraised Xf (B) Value (Bldg)	60,800
								Appraised Ob (B) Value (Bldg)	4,600
								Appraised Land Value (Bldg)	179,600
								Special Land Value	0
								Total Appraised Parcel Value	730,700
								Valuation Method	C
								Total Appraised Parcel Value	730,700

BUILDING PERMIT RECORD									VISIT / CHANGE HISTORY					
Permit Id	Issue Date	Type	Description	Amount	Insp Date	% Comp	Date Comp	Comments	Date	Id	Type	Is	Cd	Purpost/Result
EXPR-22-1	12-15-2022	835	Sid/Wind/Roof/	12,568		100		Weatherization and air sealin	12-01-2022	BM	22		22	Change of Address
201206511	10-22-2012	NW	New Windows	900	06-30-2013	100	06-30-2013	REPLC 1 WIND .29 U VALUE	07-28-2021	JD	03		16	In Office Review
201105091	09-21-2011	NW	New Windows	3,000	06-30-2012	100	06-30-2012	REPLC 5 WINDS .32 U VALU	07-17-2020	LH	03		16	In Office Review
54557	07-16-2001	RE	Remodel	11,000	12-03-2001	100	01-01-2002	FAM RM OVER GAR	06-01-2020	DM			FR	Field Review
B24567	11-01-1982	DW	Dwelling	0	01-15-1983	100	06-30-1983	MM 1 STOR	08-14-2019	JD	03		16	In Office Review
									07-23-2018	LH	03		16	In Office Review
									07-07-2017	JL	03		16	In Office Review

LAND LINE VALUATION SECTION																	
B	Use Code	Description	Zone	LA	Land Units	Unit Price	Size Adj	AC Disc	Site Index	Cond.	Nbhd.	Nbhd. Adj	Notes	Location Adjustmen	Adj Unit P	Land Value	
1	1010	Single Fam M-0	RF	3	0.470	AC	176,344.00	1.88432	1.0000	5	1.00	0106	1.150		1.0000	382,137.4	179,600
Total Card Land Units					0.47	AC	Parcel Total Land Area					0.47	Total Land Value			179,600	

CONSTRUCTION DETAIL			CONSTRUCTION DETAIL (CONTINUED)		
Element	Cd	Description	Element	Cd	Description
Style	04	Cape Cod			
Model	01	Residential			
Grade:	C	Average			
Stories	1.25	1 1/4 Stories			
Exterior Wall 1	14	Wood Shingle			
Exterior Wall 2	11	Clapboard			
RooF Structure	03	Gable/Hip			
RooF Cover	03	Asph/F Gls/Cmp			
Interior Wall 1	05	Drywall			
Interior Wall 2					
Interior Floor 1	14	Carpet			
Interior Floor 2	12	Hardwood			
Heat Fuel	02	Oil			
Heat Type	05	Hot Water			
AC Type	03	Central			
Bedrooms	03	3 Bedrooms			
Full Baths	2				
Half Baths	1				
Extra Fixtures					
Total Rooms	8	8 Rooms			
Bath Style					
Kitchen Style					
Occupancy					
Usrflid 105					
Accessory Apt					
Foundation Alt	01	Poured Conc.			
Rms Prts					
Bath Split	21	2 Full-1 Half			

CONDO DATA			
Parcel Id		C	Owne 0.0
		B	S
Adjust Type	Code	Description	Factor%
Condo Flr			
Condo Unit			

COST / MARKET VALUATION	
Building Value New	585,229
Year Built	1982
Effective Year Built	1997
Depreciation Code	A
Remodel Rating	
Year Remodeled	
Depreciation %	17
Functional Obsol	0
External Obsol	0
Trend Factor	1
Condition	
Condition %	
Percent Good	83
RCNLD	485,700
Dep % Ovr	
Dep Ovr Comment	
Misc Imp Ovr	
Misc Imp Ovr Comment	
Cost to Cure Ovr	
Cost to Cure Ovr Comment	

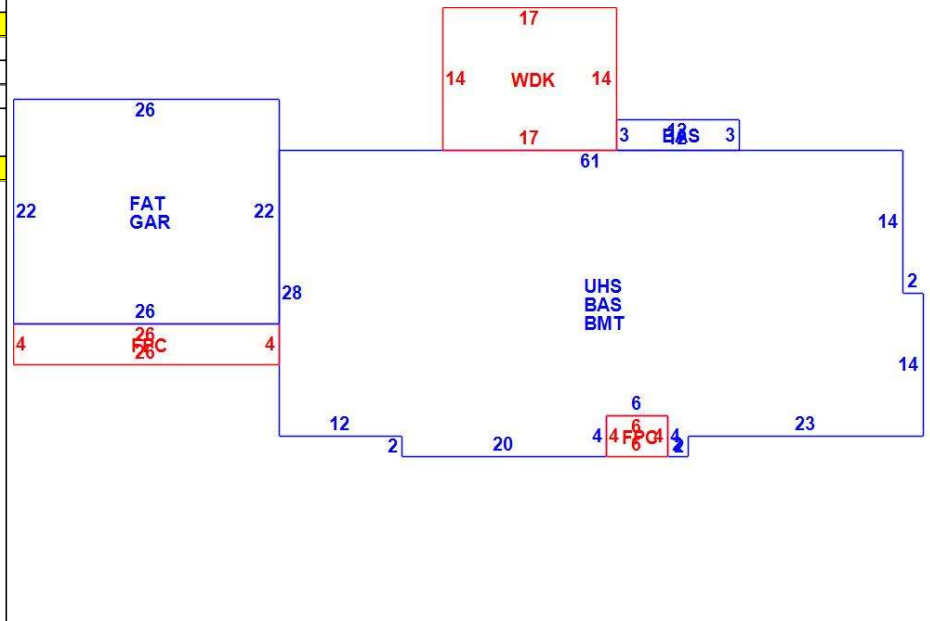

OB - OUTBUILDING & YARD ITEMS(L) / XF - BUILDING EXTRA FEATURES(B)										
Code	Description	L/B	Units	Unit Price	Yr Blt	Cond. Cd	% Gd	Grade	Grade Adj.	Appr. Value
FPL1	Fireplace 1 sto	B	1	5000.00	1999		83		0.00	4,200
FPO	Ext FP Openin	B	1	2000.00	1999		83		0.00	1,700
WDC	Wood Decking	L	238	20.00	2013		88		0.00	4,600
FOPC	Open Prch-roo	B	128	55.00	1999		83		0.00	4,500
GAR	Attached Gara	B	572	40.00	1999		83		0.00	16,900
BMT	Basement-Unfi	B	1,768	26.01	1999		83		0.00	33,500

BUILDING SUB-AREA SUMMARY SECTION						
Code	Description	Living Area	Floor Area	Eff Area	Unit Cost	Undeprec Value
BAS	First Floor	1,804	1,804	1,804	241.83	436,261
BMT	Basement Area	0	1,768	0	0.00	0
FAT	Attic, Finished	86	572	86	36.36	20,797
FPC	Open Porch Conc. Floor	0	128	0	0.00	0
GAR	Attached Garage	0	572	0	0.00	0
UHS	Half Story, Unfinished	0	1,768	530	72.49	128,170
WDK	Wood Deck	0	238	0	0.00	0
Ttl Gross Liv / Lease Area		1,890	6,850	2,420		585,228

