

| CURRENT OWNER | | TOPO | | UTILITIES | | STRT / ROAD | | LOCATION | | CURRENT ASSESSMENT | | | | 801 FY2024 BARNSTABLE, MA VISION | | | | | |
|---|------------|------------------|-------------|-------------------|--------------|-------------|------------------------|---|------------|-------------------------------|-------|-------------------------|------------------|--|--------------------|--------------------------------|-----------------------|--------------------|--------------------|
| LLOYD, BOARDMAN TR BOARDMAN LLOYD TRUST 210 ALLANDALE ROAD APT 3A CHESTNUT HIL MA 02467 | | 1 | Level | 6 | Septic | 1 | Paved | | | Description | Code | Assessed | Assessed | | | RESIDENTL RES LAND | 1010 1010 | 692,200 204,600 | 692,200 204,600 |
| | | | | 4 | Gas | | | | | | | | | | | | | | |
| | | | | 2 | Public Water | | | | | | | | | | | | | | |
| SUPPLEMENTAL DATA | | | | | | | | | | Total | | | | 896,800 | 896,800 | | | | |
| Alt Prcl ID | | Split Zonin | | Plan Ref. | | 349/53 | | | | | | | | | | | | | |
| BID Parcel | | ResExpt Q | | Land Ct# | | #SR | | | | | | | | | | | | | |
| #DL 1 | | LOT 50 | | Life Estate | | PP STATU | | A:Active | | | | | | | | | | | |
| #DL 2 | | | | Assoc Pid# | | | | | | | | | | | | | | | |
| GIS ID | | F_949990_2706614 | | | | | | | | | | | | | | | | | |
| RECORD OF OWNERSHIP | | | | BK-VOL/PAGE | | SALE DATE | | Q/U | | V/I | | SALE PRIC | | VC | | PREVIOUS ASSESSMENTS (HISTORY) | | | |
| LLOYD, BOARDMAN TR ROMEISER, DAVID E & PRISCILLA ROMEISER, DAVID BRUNE, STEPHEN S & BARBARA RYAN, JAMES A | | | | 21956 | 0215 | 04-19-2007 | Q | I | 635,000 | 00 | Year | Code | Assessed | Year | Code | Assessed | Year | Code | Assessed |
| | | | | 10095 | 0184 | 03-15-1996 | U | I | 1 | A | 2023 | 1010 | 615,500 | 2022 | 1010 | 525,000 | 2021 | 1010 | 449,500 |
| | | | | 5084 | 0240 | 05-15-1986 | Q | V | 90,000 | U | | 1010 | 202,400 | | 1010 | 144,400 | | 1010 | 144,400 |
| | | | | 4600 | 0140 | 06-15-1985 | Q | V | 50,000 | U | | | | | | | | 1010 | 5,600 |
| | | | | 3343 | 0340 | 08-14-1981 | Q | | 15,600 | U | | | | | | | | | |
| Total | | | | | | | | | | Total | | 817,900 | Total | | 669,400 | Total | | 599,500 | |
| EXEMPTIONS | | | | OTHER ASSESSMENTS | | | | This signature acknowledges a visit by a Data Collector or Assessor | | | | | | | | | | | |
| Year | Code | Description | | Amount | | Code | Description | | Number | Amount | | Comm Int | | | | | | | |
| | | | | | | | | | | | | | | | | | | | |
| Total | | | | 0.00 | | | | | | | | | | | | | | | |
| ASSESSING NEIGHBORHOOD | | | | | | | | | | | | APPRAISED VALUE SUMMARY | | | | | | | |
| Nbhd | | Nbhd Name | | B | | Tracing | | Batch | | Appraised Bldg. Value (Card) | | | | 606,000 | | | | | |
| 0106 | | | | | | | | MARSTM | | Appraised Xf (B) Value (Bldg) | | | | 80,600 | | | | | |
| | | | | | | | | Appraised Ob (B) Value (Bldg) | | | | 5,600 | | | | | | | |
| | | | | | | | | Appraised Land Value (Bldg) | | | | 204,600 | | | | | | | |
| | | | | | | | | Special Land Value | | | | 0 | | | | | | | |
| | | | | | | | | Total Appraised Parcel Value | | | | 896,800 | | | | | | | |
| | | | | | | | | Valuation Method | | | | C | | | | | | | |
| | | | | | | | | Total Appraised Parcel Value | | | | 896,800 | | | | | | | |
| BUILDING PERMIT RECORD | | | | | | | | | | | | VISIT / CHANGE HISTORY | | | | | | | |
| Permit Id | Issue Date | Type | Description | Amount | Insp Date | % Comp | Date Comp | Comments | | | | Date | Id | Type | Is | Cd | Purpost/Result | | |
| 19-4226 | 12-23-2019 | 822 | Insulation | 5,323 | | 100 | | 10" layer Cellulose Open Attic, | | | | 05-15-2020 | LS | | | FR | Field Review | | |
| 201002090 | 05-14-2010 | WD | Wood Deck | 3,660 | 08-30-2010 | 100 | 06-30-2011 | REBLD PART OF EXIST DEC | | | | 05-05-2020 | SR | 02 | | 03 | Cycl Insp Comp | | |
| 200905210 | 10-27-2009 | FP | Fireplace | 10,000 | 10-20-2010 | 100 | 06-30-2011 | REMOVE & REPL 2 CHIMNE | | | | 07-30-2018 | KM | 22 | | 22 | Change of Address | | |
| 200705144 | 08-17-2007 | WD | Wood Deck | 2,200 | 06-30-2008 | 100 | 06-30-2008 | 6X10 WDK, DOOR, SKYLTS | | | | 12-27-2010 | RB | 03 | | 02 | Bldg Permit Completed | | |
| 200703663 | 07-25-2007 | RE | Remodel | 32,000 | 10-18-2007 | 100 | 06-30-2007 | GARAGE | | | | 10-20-2010 | MK | 02 | | 52 | New Construction | | |
| B30614 | 04-01-1987 | DW | Dwelling | 100,000 | 01-15-1989 | 100 | 12-31-1989 | MM 2 STOR | | | | 08-30-2010 | MK | 02 | | 52 | New Construction | | |
| | | | | | | | | | | | | 10-18-2007 | PT | 02 | | 14 | Cyclical Inspection | | |
| LAND LINE VALUATION SECTION | | | | | | | | | | | | | | | | | | | |
| B | Use Code | Description | Zone | LA | Land Units | Unit Price | Size Adj | AC Disc | Site Index | Cond. | Nbhd. | Nbhd. Adj | Notes | | Location Adjustmen | | Adj Unit P | Land Value | |
| 1 | 1010 | Single Fam M-0 | RF | 3 | 1.000 | AC | 176,344.00 | 1.00000 | 1.0000 | 5 | 1.00 | 0106 | 1.150 | BOG FRONT | | 1.0000 | 202,795.6 | 202,800 | |
| 1 | 1010 | Single Fam M-0 | RF | 3 | 0.110 | AC | 14,250.00 | 1.00000 | 1.0000 | 0 | 1.00 | 0106 | 1.150 | | | 1.0000 | 16,387.5 | 1,800 | |
| Total Card Land Units | | | | | 1.11 | AC | Parcel Total Land Area | | | | | 1.11 | Total Land Value | | | | | 204,600 | |

| CONSTRUCTION DETAIL | | | CONSTRUCTION DETAIL (CONTINUED) | | |
|---------------------|------|----------------|---------------------------------|----|-------------|
| Element | Cd | Description | Element | Cd | Description |
| Style | 04 | Cape Cod | | | |
| Model | 01 | Residential | | | |
| Grade: | C+ | Average Plus | | | |
| Stories | 1.75 | 1 3/4 Stories | | | |
| Exterior Wall 1 | 14 | Wood Shingle | | | |
| Exterior Wall 2 | 11 | Clapboard | | | |
| RooF Structure | 03 | Gable/Hip | | | |
| RooF Cover | 03 | Asph/F Gls/Cmp | | | |
| Interior Wall 1 | 05 | Drywall | | | |
| Interior Wall 2 | | | | | |
| Interior Floor 1 | 14 | Carpet | | | |
| Interior Floor 2 | 12 | Hardwood | | | |
| Heat Fuel | 02 | Oil | | | |
| Heat Type | 05 | Hot Water | | | |
| AC Type | 03 | Central | | | |
| Bedrooms | 04 | 4 Bedrooms | | | |
| Full Baths | 2 | | | | |
| Half Baths | 1 | | | | |
| Extra Fixtures | | | | | |
| Total Rooms | 9 | | | | |
| Bath Style | | | | | |
| Kitchen Style | | | | | |
| Occupancy | | | | | |
| Usrflid 105 | | | | | |
| Accessory Apt | | | | | |
| Foundation Alt | 01 | Poured Conc. | | | |
| Rms Prts | | | | | |
| Bath Split | 21 | 2 Full-1 Half | | | |

| CONDO DATA | | | | |
|-------------|------|-------------|---------|---|
| Parcel Id | C | Owne | 0.0 | |
| | | | B | S |
| Adjust Type | Code | Description | Factor% | |
| Condo Flr | | | | |
| Condo Unit | | | | |

| COST / MARKET VALUATION | |
|--------------------------|---------|
| Building Value New | 712,932 |
| Year Built | 1988 |
| Effective Year Built | 2000 |
| Depreciation Code | A |
| Remodel Rating | |
| Year Remodeled | |
| Depreciation % | 15 |
| Functional Obsol | 0 |
| External Obsol | 0 |
| Trend Factor | 1 |
| Condition | |
| Condition % | |
| Percent Good | 85 |
| RCNLD | 606,000 |
| Dep % Ovr | |
| Dep Ovr Comment | |
| Misc Imp Ovr | |
| Misc Imp Ovr Comment | |
| Cost to Cure Ovr | |
| Cost to Cure Ovr Comment | |

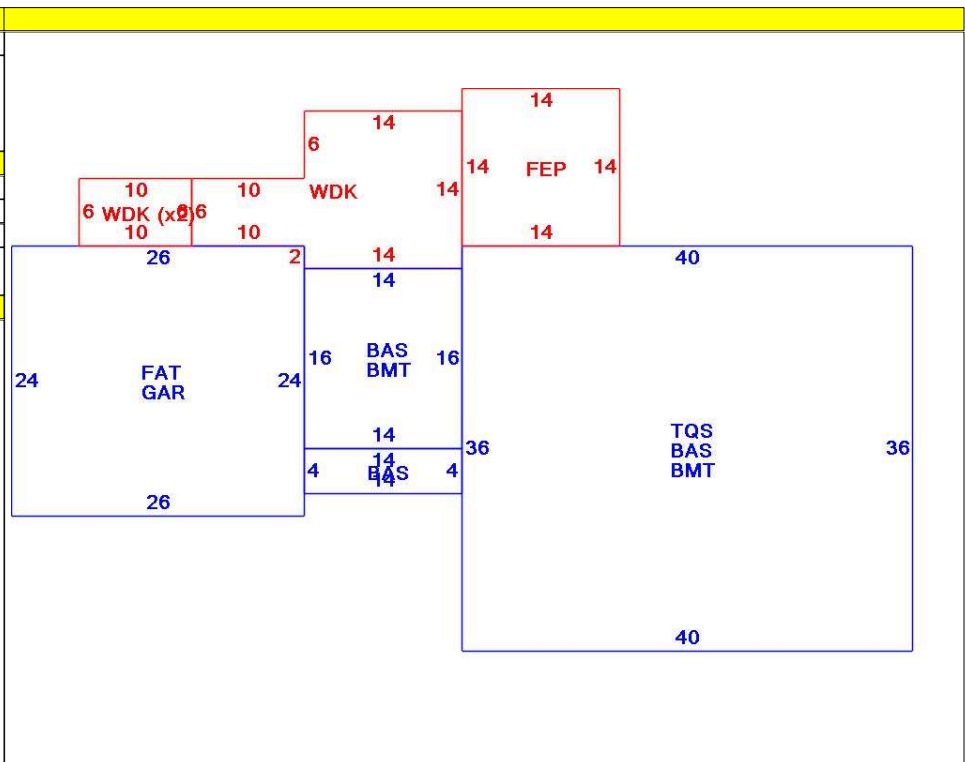

| OB - OUTBUILDING & YARD ITEMS(L) / XF - BUILDING EXTRA FEATURES(B) | | | | | | | | | | |
|--|-----------------|-----|-------|------------|--------|----------|------|-------|------------|-------------|
| Code | Description | L/B | Units | Unit Price | Yr Blt | Cond. Cd | % Gd | Grade | Grade Adj. | Appr. Value |
| FPL2 | Fireplace 1.5 s | B | 2 | 6000.00 | 2002 | | 85 | | 0.00 | 10,200 |
| BFA | Bsmt Fin-Avg | B | 600 | 17.36 | 2002 | | 85 | | 0.00 | 8,900 |
| WDC | Wood Decking | L | 376 | 20.00 | 2000 | | 62 | | 0.00 | 4,500 |
| GAR | Attached Gara | B | 624 | 40.00 | 2002 | | 85 | | 0.00 | 18,400 |
| BMT | Basement-Unfi | B | 1,664 | 26.01 | 2002 | | 85 | | 0.00 | 32,600 |
| FEP | Enclosed porc | B | 196 | 70.00 | 2002 | | 85 | | 0.00 | 10,500 |
| SHED | Shed | L | 120 | 18.00 | 1995 | | 52 | | 0.00 | 1,100 |

| BUILDING SUB-AREA SUMMARY SECTION | | | | | | |
|-----------------------------------|---------------------|-------------|------------|----------|-----------|----------------|
| Code | Description | Living Area | Floor Area | Eff Area | Unit Cost | Undeprec Value |
| BAS | First Floor | 1,720 | 1,720 | 1,720 | 259.25 | 445,907 |
| BMT | Basement Area | 0 | 1,664 | 0 | 0.00 | 0 |
| FAT | Attic, Finished | 94 | 624 | 94 | 39.05 | 24,369 |
| FEP | Enclosed Porch | 0 | 196 | 0 | 0.00 | 0 |
| GAR | Attached Garage | 0 | 624 | 0 | 0.00 | 0 |
| TQS | Three Quarter Story | 936 | 1,440 | 936 | 168.51 | 242,656 |
| WDK | Wood Deck | 0 | 376 | 0 | 0.00 | 0 |
| Ttl Gross Liv / Lease Area | | 2,750 | 6,644 | 2,750 | | 712,932 |

