

CONSTRUCTION DETAIL			CONSTRUCTION DETAIL (CONTINUED)		
Element	Cd	Description	Element	Cd	Description
Style	04	Cape Cod			
Model	01	Residential			
Grade:	C+	Average Plus			
Stories	1.5	1 1/2 Stories			
Exterior Wall 1	11	Clapboard			
Exterior Wall 2					
RooF Structure	03	Gable/Hip			
RooF Cover	03	Asph/F Gls/Cmp			
Interior Wall 1	03	Plastered			
Interior Wall 2					
Interior Floor 1	12	Hardwood			
Interior Floor 2					
Heat Fuel	03	Gas			
Heat Type	04	Hot Air			
AC Type	03	Central			
Bedrooms	03	3 Bedrooms			
Full Baths	2				
Half Baths	1				
Extra Fixtures					
Total Rooms	7	7 Rooms			
Bath Style					
Kitchen Style					
Occupancy					
Usrflid 105					
Accessory Apt					
Foundation Alt	01	Poured Conc.			
Rms Prts					
Bath Split	21	2 Full-1 Half			

CONDO DATA			
Parcel Id	C	Owne	0.0
Adjust Type	Code	Description	Factor%
Condo Flr			
Condo Unit			

COST / MARKET VALUATION	
Building Value New	695,698
Year Built	1999
Effective Year Built	2005
Depreciation Code	A
Remodel Rating	
Year Remodeled	
Depreciation %	11
Functional Obsol	0
External Obsol	0
Trend Factor	1
Condition	
Condition %	
Percent Good	89
RCNLD	619,200
Dep % Ovr	
Dep Ovr Comment	
Misc Imp Ovr	
Misc Imp Ovr Comment	
Cost to Cure Ovr	
Cost to Cure Ovr Comment	

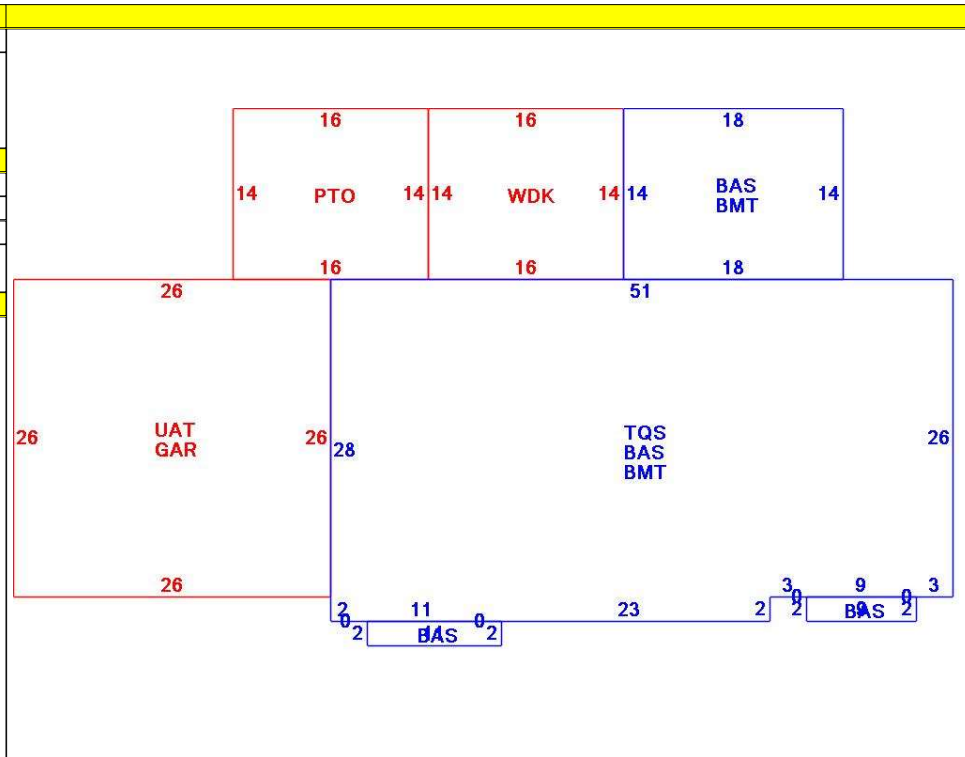

OB - OUTBUILDING & YARD ITEMS(L) / XF - BUILDING EXTRA FEATURES(B)										
Code	Description	L/B	Units	Unit Price	Yr Blt	Cond. Cd	% Gd	Grade	Grade Adj.	Appr. Value
WDC	Wood Decking	L	224	20.00	2005		72		0.00	3,600
PAT2	Patio-Good	L	224	9.94	2005		86		0.00	2,100
GAR	Attached Gara	B	676	40.00	2007		89		0.00	20,400
BMT	Basement-Unfi	B	1,650	26.01	2007		89		0.00	33,900
FPLG	Gas Fireplace-	B	1	2500.00	2007		89		0.00	2,200

BUILDING SUB-AREA SUMMARY SECTION						
Code	Description	Living Area	Floor Area	Eff Area	Unit Cost	Undeprec Value
BAS	First Floor	1,690	1,690	1,690	260.85	440,843
BMT	Basement Area	0	1,650	0	0.00	0
GAR	Attached Garage	0	676	0	0.00	0
PTO	Patio	0	224	0	0.00	0
TQS	Three Quarter Story	909	1,398	909	169.61	237,116
UAT	Attic, Unfinished	0	676	68	26.24	17,738
WDK	Wood Deck	0	224	0	0.00	0
Ttl Gross Liv / Lease Area		2,599	6,538	2,667		695,697

