

CURRENT OWNER				TOPO	UTILITIES	STRT / ROAD	LOCATION	CURRENT ASSESSMENT				
ZUBATY, THOMAS M & CYNTHIA G								Description	Code	Assessed	Assessed	801 FY2024 BARNSTABLE, MA
206 TURTLEBACK ROAD								RESIDNTL	1010	730,900	730,900	
MARSTONS MIL MA 02648								RES LAND	1010	176,400	176,400	VISION
Alt Prcl ID Split Zonin BID Parcel ResExpt Q YES: #DL 1 LOT 342 #DL 2 GIS ID F_949432_2709810				Plan Ref. Land Ct# 30751-F #SR Life Estate PP STATU Assoc Pid#				Total		907,300	907,300	

RECORD OF OWNERSHIP		BK-VOL/PAGE	SALE DATE	Q/U	V/I	SALE PRIC	VC	PREVIOUS ASSESSMENTS (HISTORY)								
ZUBATY, THOMAS M & CYNTHIA G	C198522	0	10-24-2012	Q	I	135,000	00	Year	Code	Assessed	Year	Code	Assessed	Year	Code	Assessed
BARNETT, SUMNER M & ADELLE S TRS	C146519	0	11-14-1997	U	V	0	1A	2023	1010	627,700	2022	1010	546,100	2021	1010	446,500
BARNETT, ADELLE S	C129340	0	02-15-1993	U	V	1	F		1010	160,400		1010	118,900		1010	118,900
BARNETT, SUMNER M & ADELLE	C85789	0	06-12-1981	U		0		Total		788,100	Total		665,000	Total		569,800

EXEMPTIONS				OTHER ASSESSMENTS				This signature acknowledges a visit by a Data Collector or Assessor										
Year	Code	Description	Amount	Code	Description	Number	Amount	Comm Int										
2017	5C	RESIDENTIAL EXEMPTION	0.00															
Total			0.00															

ASSESSING NEIGHBORHOOD				APPRAISED VALUE SUMMARY						
Nbhd	Nbhd Name	B	Tracing	Batch						
0105			MARSTM							
NOTES				Appraised Bldg. Value (Card)						649,600
				Appraised Xf (B) Value (Bldg)						76,900
				Appraised Ob (B) Value (Bldg)						4,400
				Appraised Land Value (Bldg)						176,400
				Special Land Value						0
				Total Appraised Parcel Value						907,300
				Valuation Method						C
				Total Appraised Parcel Value						907,300

BUILDING PERMIT RECORD								VISIT / CHANGE HISTORY							
Permit Id	Issue Date	Type	Description	Amount	Insp Date	% Comp	Date Comp	Comments	Date	Id	Type	Is	Cd	Purpost/Result	
201403684	10-16-2014	DW	Dwelling	216,125	06-26-2015	100	06-30-2015	CONSTRUCT A NEW ONE ST	05-15-2020	LS			FR	Field Review	
									07-06-2016	GC	03		16	In Office Review	
									02-03-2016	AL	22		22	Change of Address	
									07-01-2015	SR	01		02	Bldg Permit Completed	
									07-25-2013	JR	03		20	Sale Review	
									03-07-2013	DR	22		22	Change of Address	
									10-26-2005	PT	04		46	Vacant Lot	

LAND LINE VALUATION SECTION																
B	Use Code	Description	Zone	LA	Land Units	Unit Price	Size Adj	AC Disc	Site Index	Cond.	Nbhd.	Nbhd. Adj	Notes	Location Adjustmen	Adj Unit P	Land Value
1	1010	Single Fam M-0	RF	3	1.000	AC 176,344.00	1.00000	1.0000	5	1.00	0105	1.000		1.0000	176,344	176,300
1	1010	Single Fam M-0	RF	3	0.010	AC 14,250.00	1.00000	1.0000	0	1.00	0105	1.000		1.0000	14,250	100
Total Card Land Units					1.01	AC	Parcel Total Land Area					1.01	Total Land Value			176,400

CONSTRUCTION DETAIL			CONSTRUCTION DETAIL (CONTINUED)		
Element	Cd	Description	Element	Cd	Description
Style	01	Ranch			
Model	01	Residential			
Grade:	C+	Average Plus			
Stories	1	1 Story			
Exterior Wall 1	25	Vinyl Siding			
Exterior Wall 2					
Roof Structure	03	Gable/Hip			
Roof Cover	03	Asph/F Gls/Cmp			
Interior Wall 1	05	Drywall			
Interior Wall 2					
Interior Floor 1	12	Hardwood			
Interior Floor 2	14	Carpet			
Heat Fuel	03	Gas			
Heat Type	04	Hot Air			
AC Type	03	Central			
Bedrooms	03	3 Bedrooms			
Full Baths	2				
Half Baths	1				
Extra Fixtures					
Total Rooms	7				
Bath Style					
Kitchen Style					
Occupancy					
Usrflid 105					
Accessory Apt					
Foundation Alt	01	Poured Conc.			
Rms Prts					
Bath Split	21	2 Full-1 Half			

CONDO DATA				
Parcel Id		C	Owne	0.0
			B	S
Adjust Type	Code	Description	Factor%	
Condo Flr				
Condo Unit				

COST / MARKET VALUATION	
Building Value New	683,835
Year Built	2014
Effective Year Built	2013
Depreciation Code	A
Remodel Rating	
Year Remodeled	
Depreciation %	5
Functional Obsol	0
External Obsol	0
Trend Factor	1
Condition	
Condition %	
Percent Good	95
RCNLD	649,600
Dep % Ovr	
Dep Ovr Comment	
Misc Imp Ovr	
Misc Imp Ovr Comment	
Cost to Cure Ovr	
Cost to Cure Ovr Comment	

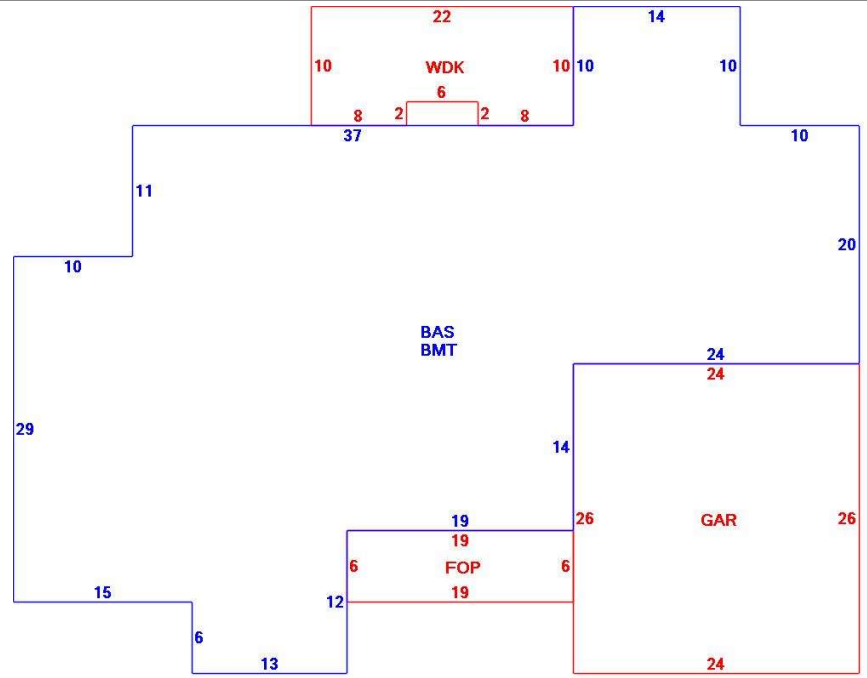

OB - OUTBUILDING & YARD ITEMS(L) / XF - BUILDING EXTRA FEATURES(B)										
Code	Description	L/B	Units	Unit Price	Yr Blt	Cond. Cd	% Gd	Grade	Grade Adj.	Appr. Value
FPLG	Gas Fireplace	B	1	2500.00	2016		95		0.00	2,400
WDC	Wood Decking	L	208	20.00	2014		90		0.00	4,400
BMT	Basement-Unfi	B	2,354	26.01	2016		95		0.00	48,200
GAR	Attached Gara	B	624	40.00	2016		95		0.00	20,500
FOP	Open Porch-ro	B	114	55.00	2016		95		0.00	5,800

BUILDING SUB-AREA SUMMARY SECTION						
Code	Description	Living Area	Floor Area	Eff Area	Unit Cost	Undeprec Value
BAS	First Floor	2,354	2,354	2,354	290.50	683,835
BMT	Basement Area	0	2,354	0	0.00	0
FOP	Open Porch	0	114	0	0.00	0
GAR	Attached Garage	0	624	0	0.00	0
WDC	Wood Deck	0	208	0	0.00	0
Ttl Gross Liv / Lease Area		2,354	5,654	2,354		683,835



06/26/2015