

| CURRENT OWNER | | TOPO | UTILITIES | STRT / ROAD | LOCATION | CURRENT ASSESSMENT | | | | | | | | |
|--|--|------|--------------|-------------|--------------|--|-------|-------|---------------|-------------|------|-----------|----------|--|
| HANAFIN, TERESA M 239 REGENCY DRIVE MARSTONS MIL MA 02648-1115 | | 3 | Below Street | 6 | Septic | 1 | Paved | 1 | Lake/Pond Fro | Description | Code | Assessed | Assessed | 801 FY2024 BARNSTABLE, MA VISION |
| | | | | 5 | Well | | | 1 | Excel View | RESIDNTL | 1010 | 860,800 | 860,800 | |
| | | | | 2 | Public Water | | | | | RES LAND | 1010 | 541,700 | 541,700 | |
| SUPPLEMENTAL DATA | | | | | | | | | | | | | | |
| Alt Prcl ID Split Zonin BID Parcel ResExpt Q YES: #DL 1 LOT 17 #DL 2 GIS ID F_951356_2711082 | | | | | | Plan Ref. Land Ct# 16427-D (SH 3) #SR Life Estate PP STATU Assoc Pid# | | Total | | 1,402,500 | | 1,402,500 | | |

| RECORD OF OWNERSHIP | | BK-VOL/PAGE | SALE DATE | Q/U | V/I | SALE PRIC | VC | PREVIOUS ASSESSMENTS (HISTORY) | | | | | | | | | |
|-----------------------------------|--|-------------|-----------|------------|-----|-----------|---------|--------------------------------|-----------|------|----------|------|-----------|----------|-------|------|----------|
| HANAFIN, TERESA M | | C204833 | 0 | 10-30-2014 | Q | I | 590,000 | 00 | Year | Code | Assessed | Year | Code | Assessed | Year | Code | Assessed |
| SAKELLARIDES, LUCY H ESTATE OF | | #D12573 | 0 | 10-29-2014 | U | I | 0 | 1A | 2023 | 1010 | 754,200 | 2022 | 1010 | 655,900 | 2021 | 1010 | 507,800 |
| SAKELLARIDES, LUCY H | | #D11894 | 0 | 04-19-2012 | U | I | 0 | 1 | | 1010 | 638,300 | | 1010 | 360,100 | | 1010 | 384,100 |
| SAKELLARIDES, HARILAOS T & LUCY H | | C117850 | 0 | 06-15-1989 | U | I | 450,000 | A | | | | | | | | 1010 | 37,700 |
| SUTPHIN, NILES O & MARGARET M | | C106237 | 0 | 05-15-1986 | Q | I | 155,000 | U | | | | | | | | | |
| Total | | | | | | | | | 1,392,500 | | Total | | 1,016,000 | | Total | | 929,600 |

| EXEMPTIONS | | | | OTHER ASSESSMENTS | | | | This signature acknowledges a visit by a Data Collector or Assessor | | | | | | | | | | |
|------------|------|-----------------------|--------|-------------------|-------------|--------|--------|---|--|--|--|--|--|--|--|--|--|--|
| Year | Code | Description | Amount | Code | Description | Number | Amount | Comm Int | | | | | | | | | | |
| 2021 | 5C | RESIDENTIAL EXEMPTION | 0.00 | | | | | | | | | | | | | | | |
| Total | | | 0.00 | | | | | | | | | | | | | | | |

| ASSESSING NEIGHBORHOOD | | | | APPRAISED VALUE SUMMARY | | | | | | | | | | | | | |
|-------------------------------|-----------|--|---|-------------------------|--|--------|--|--|--|-----------|--|--|--|--|--|--|--|
| Nbhd | Nbhd Name | | B | Tracing | | Batch | | | | | | | | | | | |
| 0111 | | | | | | MARSTM | | | | | | | | | | | |
| NOTES | | | | | | | | | | | | | | | | | |
| | | | | | | | | | | | | | | | | | |
| Appraised Bldg. Value (Card) | | | | | | | | | | 723,400 | | | | | | | |
| Appraised Xf (B) Value (Bldg) | | | | | | | | | | 99,700 | | | | | | | |
| Appraised Ob (B) Value (Bldg) | | | | | | | | | | 37,700 | | | | | | | |
| Appraised Land Value (Bldg) | | | | | | | | | | 541,700 | | | | | | | |
| Special Land Value | | | | | | | | | | 0 | | | | | | | |
| Total Appraised Parcel Value | | | | | | | | | | 1,402,500 | | | | | | | |
| Valuation Method | | | | | | | | | | C | | | | | | | |
| Total Appraised Parcel Value | | | | | | | | | | 1,402,500 | | | | | | | |

| BUILDING PERMIT RECORD | | | | | | | | VISIT / CHANGE HISTORY | | | | | | | |
|------------------------|------------|------|----------------|---------|------------|--------|------------|------------------------------|------------|----|------|----|----|-----------------------|--|
| Permit Id | Issue Date | Type | Description | Amount | Insp Date | % Comp | Date Comp | Comments | Date | Id | Type | Is | Cd | Purpost/Result | |
| 16-2938 | 10-11-2016 | 839 | Solar Panel-Re | 23,000 | | 0 | | CANCELLED - Install solar pa | 01-22-2021 | PK | 03 | | 16 | In Office Review | |
| 201403489 | 09-02-2014 | FB | Finish Basemen | 42,000 | 10-22-2014 | 100 | 06-30-2015 | FB LIVRM, PLAYRM, OFFICE, | 05-13-2020 | LS | | | FR | Field Review | |
| B34419 | 06-01-1991 | SP | Swimming Pool | 15,000 | 01-15-1992 | 100 | 06-30-1992 | MM SW.POO | 10-31-2017 | SR | 02 | | 03 | Cycl Insp Comp | |
| B33118 | 08-01-1989 | SP | Swimming Pool | 14,000 | 01-15-1992 | 100 | 06-30-1992 | MM SW.POO | 08-06-2015 | JR | 03 | | 20 | Sale Review | |
| B30953 | 07-01-1987 | DW | Dwelling | 200,000 | 01-15-1989 | 100 | 06-30-1989 | MM LOT 17 | 06-23-2015 | AL | 22 | | 22 | Change of Address | |
| | | | | | | | | | 01-13-2015 | MW | 02 | | 02 | Bldg Permit Completed | |
| | | | | | | | | | 04-23-2014 | JR | 03 | | 16 | In Office Review | |

| LAND LINE VALUATION SECTION | | | | | | | | | | | | | | | | | |
|-----------------------------|----------|----------------|------|----|------------|------------|------------------------|---------|------------|-------|-------|-----------|------------------|--------------------|------------|------------|---------|
| B | Use Code | Description | Zone | LA | Land Units | Unit Price | Size Adj | AC Disc | Site Index | Cond. | Nbhd. | Nbhd. Adj | Notes | Location Adjustmen | Adj Unit P | Land Value | |
| 1 | 1010 | Single Fam M-0 | RF | 3 | 1.000 | AC | 176,344.00 | 1.00000 | 1.0000 | 5 | 1.00 | 0111 | 3.050 | MYSTIC LAKE | 1.0000 | 537,849.2 | 537,800 |
| 1 | 1010 | Single Fam M-0 | RF | 3 | 0.090 | AC | 14,250.00 | 1.00000 | 1.0000 | 0 | 1.00 | 0111 | 3.050 | | 1.0000 | 43,462.5 | 3,900 |
| Total Card Land Units | | | | | 1.09 | AC | Parcel Total Land Area | | | | | 1.09 | Total Land Value | | | 541,700 | |

| CONSTRUCTION DETAIL | | | CONSTRUCTION DETAIL (CONTINUED) | | |
|---------------------|----|----------------|---------------------------------|----|-------------|
| Element | Cd | Description | Element | Cd | Description |
| Style | 01 | Ranch | | | |
| Model | 01 | Residential | | | |
| Grade: | B- | Custom Minus | | | |
| Stories | 1 | 1 Story | | | |
| Exterior Wall 1 | 11 | Clapboard | | | |
| Exterior Wall 2 | | | | | |
| Roof Structure | 03 | Gable/Hip | | | |
| Roof Cover | 03 | Asph/F Gls/Cmp | | | |
| Interior Wall 1 | 05 | Drywall | | | |
| Interior Wall 2 | | | | | |
| Interior Floor 1 | 11 | Ceram Clay Til | | | |
| Interior Floor 2 | 12 | Hardwood | | | |
| Heat Fuel | 02 | Oil | | | |
| Heat Type | 04 | Hot Air | | | |
| AC Type | 03 | Central | | | |
| Bedrooms | 03 | 3 Bedrooms | | | |
| Full Baths | 2 | | | | |
| Half Baths | 1 | | | | |
| Extra Fixtures | | | | | |
| Total Rooms | 6 | | | | |
| Bath Style | | | | | |
| Kitchen Style | | | | | |
| Occupancy | | | | | |
| Usrflid 105 | | | | | |
| Accessory Apt | | | | | |
| Foundation Alt | 01 | Poured Conc. | | | |
| Rms Prts | | | | | |
| Bath Split | 21 | 2 Full-1 Half | | | |

| CONDO DATA | | | | |
|-------------|------|-------------|---------|----------|
| Parcel Id | | C | | Owne 0.0 |
| | | | B | S |
| Adjust Type | Code | Description | Factor% | |
| Condo Flr | | | | |
| Condo Unit | | | | |

| COST / MARKET VALUATION | | |
|--------------------------|--|---------|
| Building Value New | | 861,146 |
| Year Built | | 1987 |
| Effective Year Built | | 1999 |
| Depreciation Code | | A |
| Remodel Rating | | |
| Year Remodeled | | |
| Depreciation % | | 16 |
| Functional Obsol | | 0 |
| External Obsol | | 0 |
| Trend Factor | | 1 |
| Condition | | |
| Condition % | | |
| Percent Good | | 84 |
| RCNLD | | 723,400 |
| Dep % Ovr | | |
| Dep Ovr Comment | | |
| Misc Imp Ovr | | |
| Misc Imp Ovr Comment | | |
| Cost to Cure Ovr | | |
| Cost to Cure Ovr Comment | | |

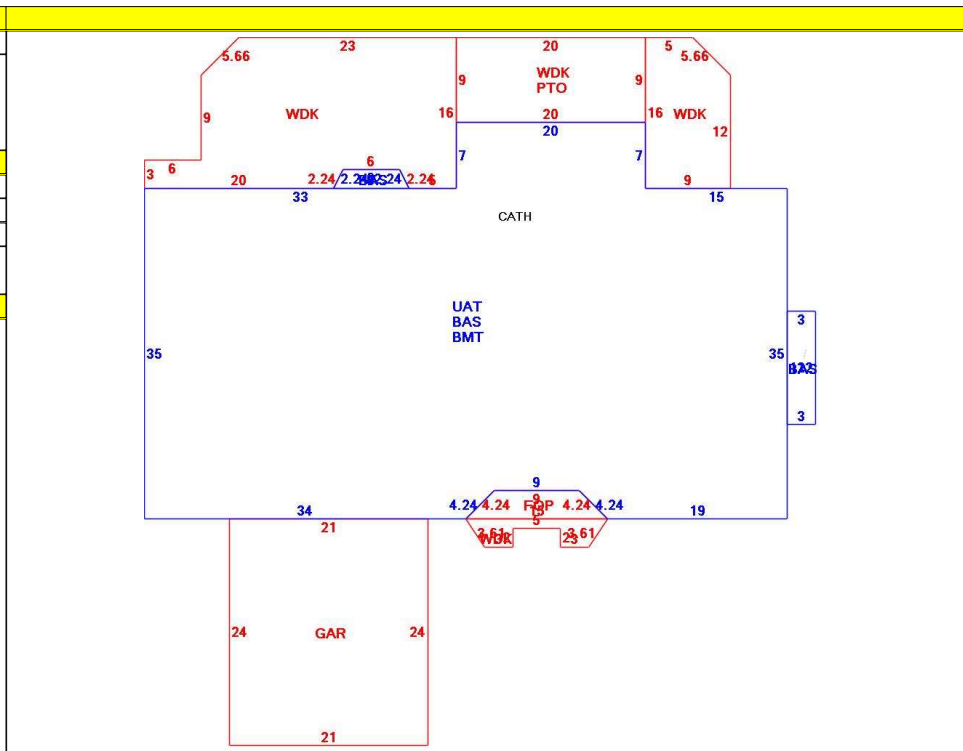

| OB - OUTBUILDING & YARD ITEMS(L) / XF - BUILDING EXTRA FEATURES(B) | | | | | | | | | | |
|--|----------------|-----|-------|------------|--------|----------|------|-------|------------|-------------|
| Code | Description | L/B | Units | Unit Price | Yr Blt | Cond. Cd | % Gd | Grade | Grade Adj. | Appr. Value |
| FPLG | Gas Fireplace- | B | 1 | 2500.00 | 2001 | | 84 | | 0.00 | 2,100 |
| BFA1 | Bsmt Fin-Goo | B | 1,285 | 32.56 | 2001 | | 84 | | 0.00 | 35,100 |
| SPL3 | Pool Gunite | L | 432 | 75.00 | 1989 | | 40 | 00 | 1.00 | 15,200 |
| WDC | Wood Decking | L | 744 | 20.00 | 2014 | | 90 | | 0.00 | 12,200 |
| PATF | Flagstone Pav | L | 180 | 30.00 | 2000 | | 81 | | 0.00 | 4,900 |
| FOP | Open Porch-ro | B | 36 | 55.00 | 2001 | | 84 | | 0.00 | 2,300 |
| GAR | Attached Gara | B | 504 | 40.00 | 2001 | | 84 | | 0.00 | 15,600 |
| BMT | Basement-Unfi | B | 2,484 | 26.01 | 2001 | | 84 | | 0.00 | 44,600 |
| PAT1 | Patio- Average | L | 1,120 | 5.89 | 1989 | | 70 | | 0.00 | 4,100 |
| WDC | Wood Decking | L | 29 | 20.00 | 2000 | | 62 | | 0.00 | 1,300 |

| BUILDING SUB-AREA SUMMARY SECTION | | | | | | |
|-----------------------------------|-------------------|-------------|------------|----------|-----------|----------------|
| Code | Description | Living Area | Floor Area | Eff Area | Unit Cost | Undeprec Value |
| BAS | First Floor | 2,534 | 2,534 | 2,534 | 309.54 | 784,380 |
| BMT | Basement Area | 0 | 2,484 | 0 | 0.00 | 0 |
| FOP | Open Porch | 0 | 36 | 0 | 0.00 | 0 |
| GAR | Attached Garage | 0 | 504 | 0 | 0.00 | 0 |
| PTO | Patio | 0 | 180 | 0 | 0.00 | 0 |
| UAT | Attic, Unfinished | 0 | 2,484 | 248 | 30.90 | 76,766 |
| WDK | Wood Deck | 0 | 773 | 0 | 0.00 | 0 |
| Ttl Gross Liv / Lease Area | | 2,534 | 8,995 | 2,782 | | 861,146 |



8.9.2017