

CURRENT OWNER			TOPO	UTILITIES	STRT / ROAD	LOCATION	CURRENT ASSESSMENT				
TEHAN, THOMAS J			1 Level	6 Septic	1 Paved		Description	Code	Assessed	Assessed	801 FY2024 BARNSTABLE, MA
12 CRANBERRY LANE				4 Gas			RESIDNTL	1010	333,300	333,300	
PEMBROKE MA 02359				2 Public Water			RES LAND	1010	157,200	157,200	
			SUPPLEMENTAL DATA								
			Alt Prcl ID Split Zonin BID Parcel ResExpt Q #DL 1 LOT 27 #DL 2 GIS ID F_949564_2711746		Plan Ref. Land Ct# 37712-B #SR Life Estate THOMAS J TEHA PP STATU Assoc Pid#		Total		490,500	490,500	VISION

RECORD OF OWNERSHIP		BK-VOL/PAGE	SALE DATE	Q/U	V/I	SALE PRIC	VC	PREVIOUS ASSESSMENTS (HISTORY)								
TEHAN, THOMAS J	C192703	0	10-19-2010	U	I	1	1A	Year	Code	Assessed	Year	Code	Assessed	Year	Code	Assessed
TEHAN, THOMAS J	C169281	0	05-27-2003	Q	I	270,000	00	2023	1010	288,100	2022	1010	252,700	2021	1010	206,300
CORRIGAN, ELLEN B & AINSWORTH J & CORRIGAN, ELLEN B	C132249	0	12-15-1993	U	I	1	A		1010	142,900			105,800		1010	105,800
DENNIS STAR CONSTRUCTION CORPO	C115932	0	11-15-1988	Q	I	138,000	U								1010	2,900
	C91728	0	05-15-1983	U	V	57,120	N	Total		431,000	Total		358,500	Total		315,000

EXEMPTIONS				OTHER ASSESSMENTS			
Year	Code	Description	Amount	Code	Description	Number	Amount
Total			0.00				

ASSESSING NEIGHBORHOOD			
Nbhd	Nbhd Name	B	Tracing
0105			MARSTM

NOTES			
This signature acknowledges a visit by a Data Collector or Assessor			
APPRAISED VALUE SUMMARY			
Appraised Bldg. Value (Card)			284,800
Appraised Xf (B) Value (Bldg)			45,600
Appraised Ob (B) Value (Bldg)			2,900
Appraised Land Value (Bldg)			157,200
Special Land Value			0
Total Appraised Parcel Value			490,500
Valuation Method			C
Total Appraised Parcel Value			490,500

BUILDING PERMIT RECORD									VISIT / CHANGE HISTORY					
Permit Id	Issue Date	Type	Description	Amount	Insp Date	% Comp	Date Comp	Comments	Date	Id	Type	Is	Cd	Purpost/Result
B31269	10-01-1987	DW	Dwelling	50,000	03-15-1989	100	06-30-1989	MM 1 STOR	05-13-2020	LS			FR	Field Review
									03-11-2015	SR	02		03	Cycl Insp Comp
									11-15-2012	DR	22		22	Change of Address
									11-01-2005	PT	02		01	Meas/Est
									02-23-2004	GB			03	Cycl Insp Comp
									11-10-2003	PT	02		01	Meas/Est
									03-19-1999	DD	01		00	Meas/Listed-Interior Acces

LAND LINE VALUATION SECTION																
B	Use Code	Description	Zone	LA	Land Units	Unit Price	Size Adj	AC Disc	Site Index	Cond.	Nbhd.	Nbhd. Adj	Notes	Location Adjustmen	Adj Unit P	Land Value
1	1010	Single Fam M-0	RF	3	0.500	AC	176,344.00	1.78240	1.0000	5	1.00	0105	1.000		1.0000	314,315.5
Total Card Land Units					0.50	AC	Parcel Total Land Area					0.50	Total Land Value			157,200

CONSTRUCTION DETAIL			CONSTRUCTION DETAIL (CONTINUED)		
Element	Cd	Description	Element	Cd	Description
Style	01	Ranch			
Model	01	Residential			
Grade:	C	Average			
Stories	1	1 Story			
Exterior Wall 1	14	Wood Shingle			
Exterior Wall 2					
RooF Structure	03	Gable/Hip			
RooF Cover	03	Asph/F Gls/Cmp			
Interior Wall 1	05	Drywall			
Interior Wall 2					
Interior Floor 1	14	Carpet			
Interior Floor 2	05	Vinyl/Asphalt			
Heat Fuel	03	Gas			
Heat Type	05	Hot Water			
AC Type	01	None			
Bedrooms	02	2 Bedrooms			
Full Baths	1				
Half Baths	1				
Extra Fixtures					
Total Rooms	4	4 Rooms			
Bath Style					
Kitchen Style					
Occupancy					
Usrflid 105					
Accessory Apt					
Foundation Alt	01	Poured Conc.			
Rms Prts					
Bath Split	11	1 Full-1 Half			

CONDO DATA			
Parcel Id		C	Owne 0.0
		B	S
Adjust Type	Code	Description	Factor%
Condo Flr			
Condo Unit			

COST / MARKET VALUATION	
Building Value New	335,108
Year Built	1988
Effective Year Built	2000
Depreciation Code	A
Remodel Rating	
Year Remodeled	
Depreciation %	15
Functional Obsol	0
External Obsol	0
Trend Factor	1
Condition	
Condition %	
Percent Good	85
RCNLD	284,800
Dep % Ovr	
Dep Ovr Comment	
Misc Imp Ovr	
Misc Imp Ovr Comment	
Cost to Cure Ovr	
Cost to Cure Ovr Comment	

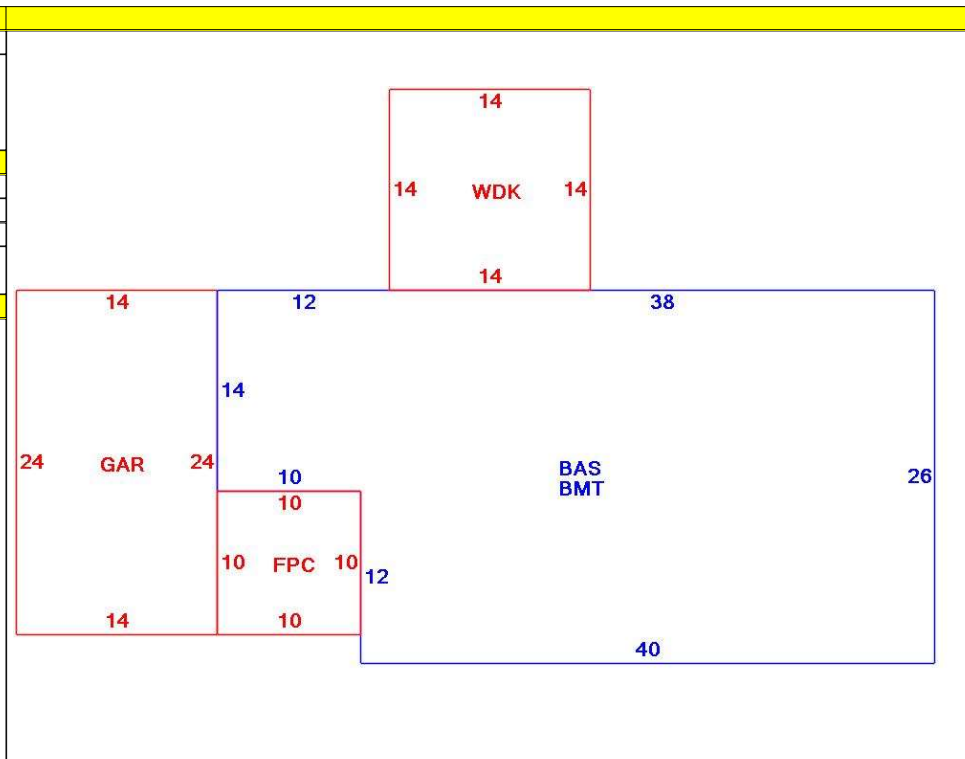

OB - OUTBUILDING & YARD ITEMS(L) / XF - BUILDING EXTRA FEATURES(B)										
Code	Description	L/B	Units	Unit Price	Yr Blt	Cond. Cd	% Gd	Grade	Grade Adj.	Appr. Value
FPL1	Fireplace 1 sto	B	1	5000.00	2002		85		0.00	4,300
WDC	Wood Decking	L	196	20.00	2000		62		0.00	2,900
FOPC	Open Prch-roo	B	100	55.00	2002		85		0.00	3,900
GAR	Attached Gara	B	336	40.00	2002		85		0.00	12,200
BMT	Basement-Unfi	B	1,180	26.01	2002		85		0.00	25,200

BUILDING SUB-AREA SUMMARY SECTION						
Code	Description	Living Area	Floor Area	Eff Area	Unit Cost	Undeprec Value
BAS	First Floor	1,180	1,180	1,180	283.99	335,108
BMT	Basement Area	0	1,180	0	0.00	0
FPC	Open Porch Conc. Floor	0	100	0	0.00	0
GAR	Attached Garage	0	336	0	0.00	0
WDC	Wood Deck	0	196	0	0.00	0
Ttl Gross Liv / Lease Area		1,180	2,992	1,180		335,108

