

| CURRENT OWNER   |  | TOPO        | UTILITIES      | STRT / ROAD       | LOCATION     | CURRENT ASSESSMENT |           |           |           |
|---|--|-------------|----------------|-------------------|--------------|--------------------|-----------|-----------|-----------|
| JENKINS, JOSEPH R TR<br>SOUTH BLUFF REALTY TRUST OF 1<br>116 FLANDERS ROAD SUITE 1100<br><br>WESTBOROUGH MA 01581 |  | 1 Level     | 6 Septic       | 1 Paved           | 7 Waterfront | Description        | Code      | Assessed  | Assessed  |
|   |  |             | 2 Public Water |                   | 1 Excel View | RESIDENTL          | 1090      | 2,509,800 | 2,509,800 |
| <b>SUPPLEMENTAL DATA</b>  |  |             |                |                   |              | RES LAND           | 1090      | 5,336,600 | 5,336,600 |
| Alt Prcl ID   |  | Split Zonin |                | Plan Ref.         |              | <b>VISION</b>      |           |           |           |
| BID Parcel  |  | ResExpt Q   |                | Land Ct# 15354-52 |              |                    |           |           |           |
| #DL 1 LOT 21  |  | #DL 2       |                | Life Estate       |              |                    |           |           |           |
| GIS ID F_952630_2684820   |  | Assoc Pid#  |                | PP STATU          |              |                    |           |           |           |
|   |  |             |                |                   |              | Total              | 7,846,400 | 7,846,400 |           |

| RECORD OF OWNERSHIP                                 |  | BK-VOL/PAGE | SALE DATE | Q/U        | V/I | SALE PRIC | VC        | PREVIOUS ASSESSMENTS (HISTORY) |           |           |           |      |      |           |
|---|--|-------------|-----------|------------|-----|-----------|-----------|--------------------------------|-----------|-----------|-----------|------|------|-----------|
| JENKINS, JOSEPH R TR<br>PHEENEY, HERBERT S & PAMELA |  | C145119     | 0         | 07-09-1997 | Q   | I         | 5,140,000 | 00                             | Year      | Code      | Assessed  | Year | Code | Assessed  |
|   |  | C69522      | 0         | 01-05-1977 | U   |           | 0         |                                | 2023      | 1090      | 2,173,400 | 2022 | 1090 | 1,853,700 |
|   |  |             |           |            |     |           |           |                                | 1090      | 4,887,800 |           | 2021 | 1090 | 4,389,100 |
|   |  |             |           |            |     |           |           |                                | 1090      |           |           |      | 1090 | 313,200   |
|   |  |             |           |            |     | Total     | 7,061,200 | Total                          | 6,508,800 | Total     | 5,893,900 |      |      |           |

| EXEMPTIONS |      |             |        | OTHER ASSESSMENTS |             |        |        |
|------------|------|-------------|--------|-------------------|-------------|--------|--------|
| Year       | Code | Description | Amount | Code              | Description | Number | Amount |
|            |      |             | 0.00   |                   |             |        |        |
| Total      |      |             | 0.00   |                   |             |        |        |

| ASSESSING NEIGHBORHOOD |           |   |         |
|------------------------|-----------|---|---------|
| Nbhd                   | Nbhd Name | B | Tracing |
| WF14                   |           |   | OSTVIL  |

| NOTES |  |  |  |
|-------|--|--|--|
|       |  |  |  |

| BUILDING PERMIT RECORD |            |      |                |         |            |        |            |                                   | VISIT / CHANGE HISTORY |    |      |    |    |                       |
|------------------------|------------|------|----------------|---------|------------|--------|------------|-----------------------------------|------------------------|----|------|----|----|-----------------------|
| Permit Id              | Issue Date | Type | Description    | Amount  | Insp Date  | % Comp | Date Comp  | Comments                          | Date                   | Id | Type | Is | Cd | Purpost/Result        |
| BLDR-21-11             | 09-30-2021 | 809  | Deck           | 30,000  |            | 0      |            | Rebuild existing deteriorated w   | 05-11-2022             | SR | 01   |    | 02 | Bldg Permit Completed |
| EXPR-21-1              | 08-23-2021 | 835  | Sid/Wind/Roof/ | 21,000  | 06-30-2022 | 100    | 06-30-2022 | Remove existing red cedar roo     | 05-18-2021             | SR | 01   |    | 13 | CALL BACK             |
| SM-21-21               | 03-25-2021 | 834  | Sheet Metal    | 10,000  | 06-30-2021 | 100    | 06-30-2021 | installation of (1) new air syste | 06-12-2020             | WD |      |    | 25 | NO TRESPASSING        |
| TB-20-2580             | 12-16-2020 | 804  | Addn Alt-Res   | 500,000 | 05-11-2022 | 100    | 06-30-2022 | Extend second floor gable out     | 07-17-2019             | CK | 22   |    | 22 | Change of Address     |
| 20-3003                | 10-14-2020 | 835  | Sid/Wind/Roof/ | 150,000 | 06-30-2021 | 100    | 06-30-2021 | Remove and replace red cedar      | 04-04-2016             | SR | 01   |    | 02 | Bldg Permit Completed |
| 201508343              | 12-08-2015 | AD   | Addition       | 20,000  | 03-30-2016 | 100    | 06-30-2016 | ADD A 12X14 SHED ROOF A           | 05-26-2015             | SR | 01   |    | 02 | Bldg Permit Completed |
| 201308095              | 11-15-2013 | RA   | Remodel-Additi | 48,000  | 05-18-2015 | 100    | 06-30-2015 | ADDN TO POOL HSE 10X12-           | 06-12-2014             | MW | 01   |    | 13 | CALL BACK             |

| LAND LINE VALUATION SECTION |          |                 |      |    |            |               |                        |         |            |       |       |           |                  |                    |            |            |
|-----------------------------|----------|-----------------|------|----|------------|---------------|------------------------|---------|------------|-------|-------|-----------|------------------|--------------------|------------|------------|
| B                           | Use Code | Description     | Zone | LA | Land Units | Unit Price    | Size Adj               | AC Disc | Site Index | Cond. | Nbhd. | Nbhd. Adj | Notes            | Location Adjustmen | Adj Unit P | Land Value |
| 1                           | 1090     | Multi Hses M-01 | RF-1 | 3  | 1.000      | AC 176,344.00 | 1.00000                | 1.0000  | 5          | 1.00  | WF14  | 28.000    |                  | 1.0000             | 4,937,632  | 4,937,600  |
| Total Card Land Units       |          |                 |      |    | 1.00       | AC            | Parcel Total Land Area |         |            |       |       | 2.00      | Total Land Value |                    |            | 4,937,600  |

| CONSTRUCTION DETAIL |    |                | CONSTRUCTION DETAIL (CONTINUED) |    |             |
|---------------------|----|----------------|---------------------------------|----|-------------|
| Element             | Cd | Description    | Element                         | Cd | Description |
| Style               | 06 | Conventional   |                                 |    |             |
| Model               | 01 | Residential    |                                 |    |             |
| Grade:              | B+ | Custom Plus    |                                 |    |             |
| Stories             | 2  | 2 Stories      |                                 |    |             |
| Exterior Wall 1     | 14 | Wood Shingle   |                                 |    |             |
| Exterior Wall 2     | 11 | Clapboard      |                                 |    |             |
| RooF Structure      | 03 | Gable/Hip      |                                 |    |             |
| RooF Cover          | 10 | Wood Shingle   |                                 |    |             |
| Interior Wall 1     | 03 | Plastered      |                                 |    |             |
| Interior Wall 2     |    |                |                                 |    |             |
| Interior Floor 1    | 09 | Pine/Soft Wood |                                 |    |             |
| Interior Floor 2    | 14 | Carpet         |                                 |    |             |
| Heat Fuel           | 02 | Oil            |                                 |    |             |
| Heat Type           | 04 | Hot Air        |                                 |    |             |
| AC Type             | 03 | Central        |                                 |    |             |
| Bedrooms            | 06 | 6 Bedrooms     |                                 |    |             |
| Full Baths          | 5  |                |                                 |    |             |
| Half Baths          | 2  |                |                                 |    |             |
| Extra Fixtures      |    |                |                                 |    |             |
| Total Rooms         | 13 | 13 Rooms       |                                 |    |             |
| Bath Style          |    |                |                                 |    |             |
| Kitchen Style       |    |                |                                 |    |             |
| Occupancy           |    |                |                                 |    |             |
| Usrflid 105         | 2  |                |                                 |    |             |
| Accessory Apt       |    |                |                                 |    |             |
| Foundation Alt      | 01 | Poured Conc.   |                                 |    |             |
| Rms Prts            |    |                |                                 |    |             |
| Bath Split          | 52 | 5 Full-2 Half  |                                 |    |             |

| CONDO DATA  |      |             |         |          |
|-------------|------|-------------|---------|----------|
| Parcel Id   |      | C           |         | Owne 0.0 |
| Adjust Type | Code | Description | Factor% |          |
| Condo Flr   |      |             |         |          |
| Condo Unit  |      |             |         |          |

| COST / MARKET VALUATION  |           |
|--------------------------|-----------|
| Building Value New       | 2,141,436 |
| Year Built               | 1923      |
| Effective Year Built     | 1984      |
| Depreciation Code        | G         |
| Remodel Rating           |           |
| Year Remodeled           |           |
| Depreciation %           | 27        |
| Functional Obsol         | 0         |
| External Obsol           | 0         |
| Trend Factor             | 1         |
| Condition                |           |
| Condition %              |           |
| Percent Good             | 73        |
| RCNLD                    | 1,563,200 |
| Dep % Ovr                |           |
| Dep Ovr Comment          |           |
| Misc Imp Ovr             |           |
| Misc Imp Ovr Comment     |           |
| Cost to Cure Ovr         |           |
| Cost to Cure Ovr Comment |           |

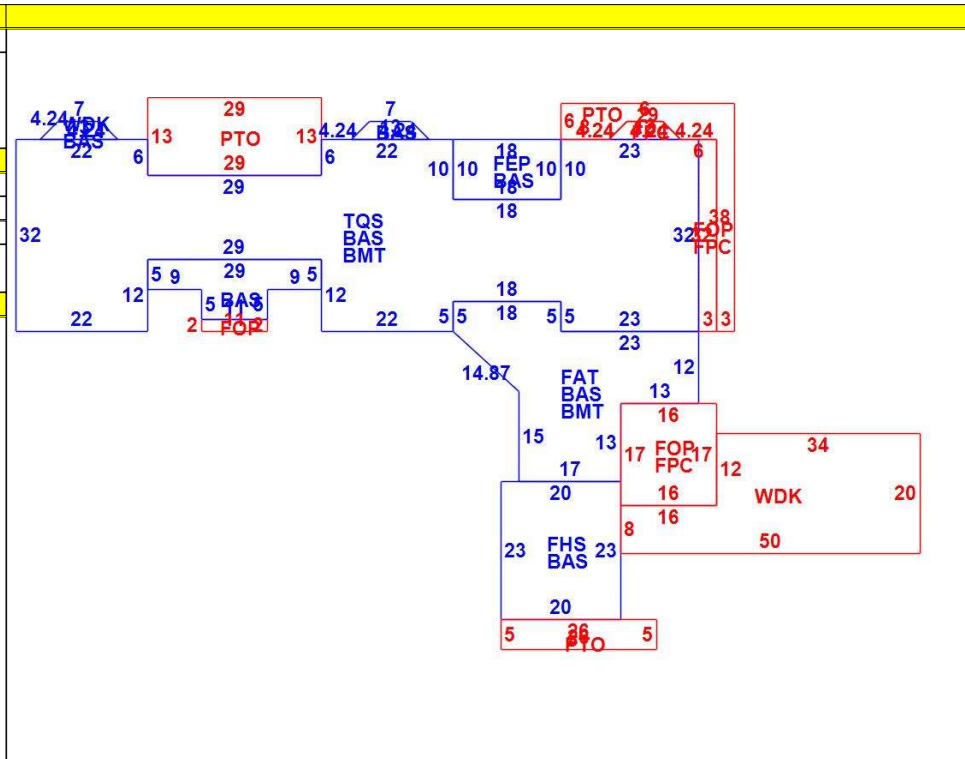

**OB - OUTBUILDING & YARD ITEMS(L) / XF - BUILDING EXTRA FEATURES(B)**

| Code | Description     | L/B | Units | Unit Price | Yr Blt | Cond. Cd | % Gd | Grade | Grade Adj. | Appr. Value |
|------|-----------------|-----|-------|------------|--------|----------|------|-------|------------|-------------|
| FPL3 | Fireplace 2 sto | B   | 2     | 7000.00    | 1984   |          | 73   |       | 0.00       | 10,200      |
| FPO  | Ext FP Openin   | B   | 1     | 2000.00    | 1984   |          | 73   |       | 0.00       | 1,500       |
| DKHD | Dock-Heavy      | L   | 1     | 205000.0   | 1994   |          | 50   |       | 0.00       | 102,500     |
| BHS1 | Beach Hse - A   | L   | 792   | 172.80     | 1980   |          | 61   | A     | 1.58       | 131,900     |
| FGR7 | Gar w/Lft Goo   | L   | 576   | 70.00      | 1999   |          | 80   | 00    | 1.00       | 32,300      |
| PAT2 | Patio-Good      | L   | 377   | 9.94       | 1996   |          | 77   |       | 0.00       | 2,900       |
| FOP  | Open Porch-ro   | B   | 87    | 55.00      | 1984   |          | 73   |       | 0.00       | 3,700       |
| BMT  | Basement-Unfi   | B   | 3,582 | 26.01      | 1984   |          | 73   |       | 0.00       | 53,800      |
| GEN  | Emergency Ge    | L   | 1     | 5550.00    | 1997   |          | 56   |       | 0.00       | 3,100       |
| FPL1 | Fireplace 1 sto | B   | 1     | 5000.00    | 1984   |          | 73   |       | 0.00       | 3,700       |

**BUILDING SUB-AREA SUMMARY SECTION**

| Code                       | Description            | Living Area | Floor Area | Eff Area | Unit Cost | Undeprec Value |
|----------------------------|------------------------|-------------|------------|----------|-----------|----------------|
| BAS                        | First Floor            | 4,482       | 4,482      | 4,482    | 320.55    | 1,436,702      |
| BMT                        | Basement Area          | 0           | 3,582      | 0        | 0.00      | 0              |
| FAT                        | Attic, Finished        | 109         | 726        | 109      | 48.13     | 34,940         |
| FEP                        | Enclosed Porch         | 0           | 180        | 0        | 0.00      | 0              |
| FHS                        | Half Story             | 230         | 460        | 230      | 160.27    | 73,726         |
| FOP                        | Open Porch             | 0           | 390        | 0        | 0.00      | 0              |
| FPC                        | Open Porch Conc. Floor | 0           | 395        | 0        | 0.00      | 0              |
| PTO                        | Patio                  | 0           | 750        | 0        | 0.00      | 0              |
| TQS                        | Three Quarter Story    | 1,856       | 2,856      | 1,856    | 208.31    | 594,940        |
| WDK                        | Wood Deck              | 0           | 838        | 0        | 0.00      | 0              |
| Ttl Gross Liv / Lease Area |                        | 6,677       | 14,659     | 6,677    |           | 2,140,308      |



| CURRENT OWNER  |  | TOPO   | UTILITIES      | STRT / ROAD | LOCATION     | CURRENT ASSESSMENT |      |           |           | 801<br>FY2024<br>BARNSTABLE, MA<br><br><b>VISION</b> |
|--|--|--|----------------|-------------|--------------|--------------------|------|-----------|-----------|--|
| JENKINS, JOSEPH R TR<br>SOUTH BLUFF REALTY TRUST OF 1<br>116 FLANDERS ROAD SUITE 1100<br><br>WESTBOROUG MA 01581 |  | 1 Level  | 6 Septic       | 1 Paved     | 7 Waterfront | Description        | Code | Assessed  | Assessed  |  |
|  |  |  | 2 Public Water |             | 1 Excel View | RESIDNTL           | 1090 | 2,509,800 | 2,509,800 |  |
| <b>SUPPLEMENTAL DATA</b>   |  |  |                |             |              | RES LAND           | 1090 | 5,336,600 | 5,336,600 |  |
| Alt Prcl ID<br>Split Zonin<br>BID Parcel<br>ResExpt Q<br>#DL 1 LOT 21<br>#DL 2<br>GIS ID F_952630_2684820        |  | Plan Ref.<br>Land Ct# 15354-52<br>#SR<br>Life Estate<br>PP STATU<br>Assoc Pid# |                |             |              | Total              |      | 7,846,400 | 7,846,400 |  |

| RECORD OF OWNERSHIP |  | BK-VOL/PAGE | SALE DATE | Q/U | V/I | SALE PRIC | VC | PREVIOUS ASSESSMENTS (HISTORY) |      |           |       |      |           |
|---------------------|--|-------------|-----------|-----|-----|-----------|----|--------------------------------|------|-----------|-------|------|-----------|
|                     |  |             |           |     |     |           |    | Year                           | Code | Assessed  | Year  | Code | Assessed  |
|                     |  |             |           |     |     |           |    | 2023                           | 1090 | 2,173,400 | 2022  | 1090 | 1,853,700 |
|                     |  |             |           |     |     |           |    |                                | 1090 | 4,887,800 |       | 1090 | 4,655,100 |
|                     |  |             |           |     |     |           |    |                                | 1090 |           | 2021  | 1090 | 313,200   |
|                     |  |             |           |     |     |           |    | Total                          |      | 7,061,200 | Total |      | 6,508,800 |
|                     |  |             |           |     |     |           |    | Total                          |      |           | Total |      | 5,893,900 |

| EXEMPTIONS                    |           |             | OTHER ASSESSMENTS |         |             |        |        | APPRAISED VALUE SUMMARY                |   |  |  |  |  |
|-------------------------------|-----------|-------------|-------------------|---------|-------------|--------|--------|--|---|--|--|--|--|
| Year                          | Code      | Description | Amount            | Code    | Description | Number | Amount | Comm Int                               | This signature acknowledges a visit by a Data Collector or Assessor |  |  |  |  |
|                               |           |             |                   |         |             |        |        |  | Appraised Bldg. Value (Card) 2,089,500                              |  |  |  |  |
| Total                         |           |             |                   |         |             |        |        |  | Appraised Xf (B) Value (Bldg) 102,200                               |  |  |  |  |
| <b>ASSESSING NEIGHBORHOOD</b> |           |             |                   |         |             |        |        | Appraised Ob (B) Value (Bldg) 318,100  |   |  |  |  |  |
| Nbhd                          | Nbhd Name |             | B                 | Tracing |             | Batch  |        | Appraised Land Value (Bldg) 5,336,600  |   |  |  |  |  |
| WF14                          |           |             |                   |         |             | OSTVIL |        | Special Land Value 0                   |   |  |  |  |  |
| <b>NOTES</b>                  |           |             |                   |         |             |        |        | Total Appraised Parcel Value 7,846,400 |   |  |  |  |  |
|                               |           |             |                   |         |             |        |        | Valuation Method C                     |   |  |  |  |  |
|                               |           |             |                   |         |             |        |        | Total Appraised Parcel Value 7,846,400 |   |  |  |  |  |

| BUILDING PERMIT RECORD |            |      |             |        |           |        |           | VISIT / CHANGE HISTORY |      |    |      |    |    |                |
|------------------------|------------|------|-------------|--------|-----------|--------|-----------|------------------------|------|----|------|----|----|----------------|
| Permit Id              | Issue Date | Type | Description | Amount | Insp Date | % Comp | Date Comp | Comments               | Date | Id | Type | Is | Cd | Purpost/Result |
|                        |            |      |             |        |           |        |           |                        |      |    |      |    |    |                |

| LAND LINE VALUATION SECTION |          |             |      |    |                        |            |          |         |            |                  |       |           |       |                    |            |            |
|-----------------------------|----------|-------------|------|----|------------------------|------------|----------|---------|------------|------------------|-------|-----------|-------|--------------------|------------|------------|
| B                           | Use Code | Description | Zone | LA | Land Units             | Unit Price | Size Adj | AC Disc | Site Index | Cond.            | Nbhd. | Nbhd. Adj | Notes | Location Adjustmen | Adj Unit P | Land Value |
|                             |          |             |      |    |                        |            |          |         |            |                  |       |           |       |                    |            |            |
| Total Card Land Units       |          |             |      |    | Parcel Total Land Area |            |          |         |            | Total Land Value |       |           |       |                    |            |            |

| CONSTRUCTION DETAIL   |                 |                |            |            |           | CONSTRUCTION DETAIL (CONTINUED) |      |             |            |             |  |
|---|-----------------|----------------|------------|------------|-----------|---------------------------------|------|-------------|------------|-------------|--|
| Element   | Cd              | Description    |            |            |           | Element                         | Cd   | Description |            |             |  |
| Style   | 06              | Conventional   |            |            |           |                                 |      |             |            |             |  |
| Model   | 01              | Residential    |            |            |           |                                 |      |             |            |             |  |
| Grade:  | B+              | Custom Plus    |            |            |           |                                 |      |             |            |             |  |
| Stories   | 2               | 2 Stories      |            |            |           |                                 |      |             |            |             |  |
| Exterior Wall 1   | 14              | Wood Shingle   |            |            |           | <b>CONDO DATA</b>               |      |             |            |             |  |
| Exterior Wall 2   | 11              | Clapboard      |            |            |           | Parcel Id                       |      | C           | Ownr       | 0.0         |  |
| Roof Structure  | 03              | Gable/Hip      |            |            |           |                                 |      | B           | S          |             |  |
| Roof Cover  | 10              | Wood Shingle   |            |            |           | Adjust Type                     | Code | Description | Factor%    |             |  |
| Interior Wall 1   | 03              | Plastered      |            |            |           | Condo Flr                       |      |             |            |             |  |
| Interior Wall 2   |                 |                |            |            |           | Condo Unit                      |      |             |            |             |  |
| Interior Floor 1  | 09              | Pine/Soft Wood |            |            |           | <b>COST / MARKET VALUATION</b>  |      |             |            |             |  |
| Interior Floor 2  | 14              | Carpet         |            |            |           | Building Value New              |      |             |            |             |  |
| Heat Fuel   | 02              | Oil            |            |            |           | Year Built                      |      |             |            |             |  |
| Heat Type   | 04              | Hot Air        |            |            |           | Effective Year Built            |      |             |            |             |  |
| AC Type   | 03              | Central        |            |            |           | Depreciation Code               |      |             |            |             |  |
| Bedrooms  | 06              | 6 Bedrooms     |            |            |           | Remodel Rating                  |      |             |            |             |  |
| Full Baths  | 5               |                |            |            |           | Year Remodeled                  |      |             |            |             |  |
| Half Baths  | 2               |                |            |            |           | Depreciation %                  |      |             |            |             |  |
| Extra Fixtures  |                 |                |            |            |           | Functional Obsol                |      |             |            |             |  |
| Total Rooms   | 13              | 13 Rooms       |            |            |           | External Obsol                  |      |             |            |             |  |
| Bath Style  |                 |                |            |            |           | Trend Factor                    |      |             |            |             |  |
| Kitchen Style   |                 |                |            |            |           | Condition                       |      |             |            |             |  |
| Occupancy   |                 |                |            |            |           | Condition %                     |      |             |            |             |  |
| Usrflid 105   | 2               |                |            |            |           | Percent Good                    |      |             |            |             |  |
| Accessory Apt   |                 |                |            |            |           | RCNLD                           |      |             |            |             |  |
| Foundation Alt  | 01              | Poured Conc.   |            |            |           | Dep % Ovr                       |      |             |            |             |  |
| Rms Prts  |                 |                |            |            |           | Dep Ovr Comment                 |      |             |            |             |  |
| Bath Split  | 52              | 5 Full-2 Half  |            |            |           | Misc Imp Ovr                    |      |             |            |             |  |
|   |                 |                |            |            |           | Misc Imp Ovr Comment            |      |             |            |             |  |
|   |                 |                |            |            |           | Cost to Cure Ovr                |      |             |            |             |  |
|   |                 |                |            |            |           | Cost to Cure Ovr Comment        |      |             |            |             |  |
| <b>OB - OUTBUILDING &amp; YARD ITEMS(L) / XF - BUILDING EXTRA FEATURES(B)</b> |                 |                |            |            |           |                                 |      |             |            |             |  |
| Code  | Description     | L/B            | Units      | Unit Price | Yr Blt    | Cond. Cd                        | % Gd | Grade       | Grade Adj. | Appr. Value |  |
| PAT1  | Patio- Average  | L              | 130        | 5.89       | 2011      |                                 | 92   | C           | 0.00       | 800         |  |
| STRS  | Stairs to Water | L              | 34         | 122.52     | 1994      |                                 | 50   | C           | 1.00       | 2,100       |  |
| WDC   | Wood Decking    | L              | 30         | 20.00      | 1997      |                                 | 56   |             | 0.00       | 1,200       |  |
| WDC   | Wood Deck w/    | L              | 808        | 18.00      | 1997      |                                 | 56   |             | 0.00       | 7,400       |  |
| WDC   | Wood Deck w/    | L              | 312        | 18.00      | 1990      |                                 | 42   |             | 0.00       | 2,300       |  |
| SHD3  | Shed-High Qu    | L              | 180        | 25.00      | 1999      |                                 | 80   |             | 0.00       | 3,600       |  |
| SHD3  | Shed-High Qu    | L              | 154        | 25.00      | 2015      |                                 | 96   |             | 0.00       | 3,700       |  |
| FEP   | Enclosed porc   | B              | 180        | 70.00      | 1984      |                                 | 73   |             | 0.00       | 8,600       |  |
| PATF  | Flagstone Pav   | L              | 243        | 30.00      | 2020      |                                 | 100  |             | 0.00       | 7,700       |  |
| FOPC  | Open Prch-roo   | B              | 395        | 55.00      | 1984      |                                 | 73   |             | 0.00       | 10,900      |  |
| <b>BUILDING SUB-AREA SUMMARY SECTION</b>                                      |                 |                |            |            |           |                                 |      |             |            |             |  |
| Code  | Description     | Living Area    | Floor Area | Eff Area   | Unit Cost | Undeprec Value                  |      |             |            |             |  |
|   |                 |                |            |            |           |                                 |      |             |            |             |  |
| Ttl Gross Liv / Lease Area  |                 |                |            |            |           |                                 |      |             |            |             |  |

| CURRENT OWNER   |  | TOPO  | UTILITIES  | STRT / ROAD | LOCATION     | CURRENT ASSESSMENT |           |           |           |
|---|--|---|--|-------------|--------------|--------------------|-----------|-----------|-----------|
| JENKINS, JOSEPH R TR<br>SOUTH BLUFF REALTY TRUST OF 1<br>116 FLANDERS ROAD SUITE 1100 |  | 1 Level   | 6 Septic   | 1 Paved     | 7 Waterfront | Description        | Code      | Assessed  | Assessed  |
|   |  |   | 2 Public Water   |             | 1 Excel View | RESIDNTL           | 1090      | 2,509,800 | 2,509,800 |
| WESTBOROUG MA 01581   |  | <b>SUPPLEMENTAL DATA</b>  |  |             | RES LAND     | 1090               | 5,336,600 | 5,336,600 |           |
|   |  | Alt Prcl ID<br>Split Zonin<br>BID Parcel<br>ResExpt Q<br>#DL 1 LOT 21<br>#DL 2<br>GIS ID F_952630_2684820 | Plan Ref.<br>Land Ct# 15354-52<br>#SR<br>Life Estate<br>PP STATU<br>Assoc Pid# | Total       |              | 7,846,400          | 7,846,400 |           |           |

801  
 FY2024  
 BARNSTABLE, MA

**VISION**

| RECORD OF OWNERSHIP |  | BK-VOL/PAGE | SALE DATE | Q/U | V/I | SALE PRIC | VC | PREVIOUS ASSESSMENTS (HISTORY) |      |           |       |      |           |
|---------------------|--|-------------|-----------|-----|-----|-----------|----|--------------------------------|------|-----------|-------|------|-----------|
|                     |  |             |           |     |     |           |    | Year                           | Code | Assessed  | Year  | Code | Assessed  |
|                     |  |             |           |     |     |           |    | 2023                           | 1090 | 2,173,400 | 2022  | 1090 | 1,853,700 |
|                     |  |             |           |     |     |           |    |                                | 1090 | 4,887,800 |       | 1090 | 4,655,100 |
|                     |  |             |           |     |     |           |    |                                | 1090 |           | 2021  | 1090 | 1,191,600 |
|                     |  |             |           |     |     |           |    |                                |      |           |       | 1090 | 4,389,100 |
|                     |  |             |           |     |     |           |    |                                |      |           |       | 1090 | 313,200   |
|                     |  |             |           |     |     |           |    | Total                          |      | 7,061,200 | Total |      | 6,508,800 |
|                     |  |             |           |     |     |           |    | Total                          |      |           | Total |      | 5,893,900 |

| EXEMPTIONS |      |             | OTHER ASSESSMENTS |      |             |        |        |          |
|------------|------|-------------|-------------------|------|-------------|--------|--------|----------|
| Year       | Code | Description | Amount            | Code | Description | Number | Amount | Comm Int |
|            |      |             |                   |      |             |        |        |          |
|            |      | Total       |                   |      |             |        |        |          |

This signature acknowledges a visit by a Data Collector or Assessor

| ASSESSING NEIGHBORHOOD |           |   |         | APPRAISED VALUE SUMMARY       |  |  |  |           |
|------------------------|-----------|---|---------|-------------------------------|--|--|--|-----------|
| Nbhd                   | Nbhd Name | B | Tracing | Batch                         |  |  |  |           |
| WF14                   |           |   |         | OSTVIL                        |  |  |  |           |
| NOTES                  |           |   |         | Appraised Bldg. Value (Card)  |  |  |  | 2,089,500 |
|                        |           |   |         | Appraised Xf (B) Value (Bldg) |  |  |  | 102,200   |
|                        |           |   |         | Appraised Ob (B) Value (Bldg) |  |  |  | 318,100   |
|                        |           |   |         | Appraised Land Value (Bldg)   |  |  |  | 5,336,600 |
|                        |           |   |         | Special Land Value            |  |  |  | 0         |
|                        |           |   |         | Total Appraised Parcel Value  |  |  |  | 7,846,400 |
|                        |           |   |         | Valuation Method              |  |  |  | C         |
|                        |           |   |         | Total Appraised Parcel Value  |  |  |  | 7,846,400 |

| BUILDING PERMIT RECORD |            |      |             |        |           |        | VISIT / CHANGE HISTORY |          |      |    |      |    |    |                |
|------------------------|------------|------|-------------|--------|-----------|--------|------------------------|----------|------|----|------|----|----|----------------|
| Permit Id              | Issue Date | Type | Description | Amount | Insp Date | % Comp | Date Comp              | Comments | Date | Id | Type | Is | Cd | Purpost/Result |
|                        |            |      |             |        |           |        |                        |          |      |    |      |    |    |                |

| LAND LINE VALUATION SECTION |          |             |      |    |                        |            |          |         |            |                  |       |           |       |                    |            |            |
|-----------------------------|----------|-------------|------|----|------------------------|------------|----------|---------|------------|------------------|-------|-----------|-------|--------------------|------------|------------|
| B                           | Use Code | Description | Zone | LA | Land Units             | Unit Price | Size Adj | AC Disc | Site Index | Cond.            | Nbhd. | Nbhd. Adj | Notes | Location Adjustmen | Adj Unit P | Land Value |
|                             |          |             |      |    |                        |            |          |         |            |                  |       |           |       |                    |            |            |
| Total Card Land Units       |          |             |      |    | Parcel Total Land Area |            |          |         |            | Total Land Value |       |           |       |                    |            |            |

| CONSTRUCTION DETAIL   |               |                |            |            |           | CONSTRUCTION DETAIL (CONTINUED) |      |             |            |             |     |
|---|---------------|----------------|------------|------------|-----------|---------------------------------|------|-------------|------------|-------------|-----|
| Element   | Cd            | Description    |            |            |           | Element                         | Cd   | Description |            |             |     |
| Style   | 06            | Conventional   |            |            |           |                                 |      |             |            |             |     |
| Model   | 01            | Residential    |            |            |           |                                 |      |             |            |             |     |
| Grade:  | B+            | Custom Plus    |            |            |           |                                 |      |             |            |             |     |
| Stories   | 2             | 2 Stories      |            |            |           |                                 |      |             |            |             |     |
| Exterior Wall 1   | 14            | Wood Shingle   |            |            |           | <b>CONDO DATA</b>               |      |             |            |             |     |
| Exterior Wall 2   | 11            | Clapboard      |            |            |           | Parcel Id                       |      | C           |            | Ownr        | 0.0 |
| Roof Structure  | 03            | Gable/Hip      |            |            |           |                                 |      |             | B          |             | S   |
| Roof Cover  | 10            | Wood Shingle   |            |            |           | Adjust Type                     | Code | Description |            | Factor%     |     |
| Interior Wall 1   | 03            | Plastered      |            |            |           | Condo Flr                       |      |             |            |             |     |
| Interior Wall 2   |               |                |            |            |           | Condo Unit                      |      |             |            |             |     |
| Interior Floor 1  | 09            | Pine/Soft Wood |            |            |           | <b>COST / MARKET VALUATION</b>  |      |             |            |             |     |
| Interior Floor 2  | 14            | Carpet         |            |            |           | Building Value New              |      |             |            |             |     |
| Heat Fuel   | 02            | Oil            |            |            |           | Year Built                      |      |             |            |             |     |
| Heat Type   | 04            | Hot Air        |            |            |           | Effective Year Built            |      |             |            |             |     |
| AC Type   | 03            | Central        |            |            |           | Depreciation Code               |      |             |            |             |     |
| Bedrooms  | 06            | 6 Bedrooms     |            |            |           | Remodel Rating                  |      |             |            |             |     |
| Full Baths  | 5             |                |            |            |           | Year Remodeled                  |      |             |            |             |     |
| Half Baths  | 2             |                |            |            |           | Depreciation %                  |      |             |            |             |     |
| Extra Fixtures  |               |                |            |            |           | Functional Obsol                |      |             |            |             |     |
| Total Rooms   | 13            | 13 Rooms       |            |            |           | External Obsol                  |      |             |            |             |     |
| Bath Style  |               |                |            |            |           | Trend Factor                    |      |             |            |             |     |
| Kitchen Style   |               |                |            |            |           | Condition                       |      |             |            |             |     |
| Occupancy   |               |                |            |            |           | Condition %                     |      |             |            |             |     |
| Usrflid 105   | 2             |                |            |            |           | Percent Good                    |      |             |            |             |     |
| Accessory Apt   |               |                |            |            |           | RCNLD                           |      |             |            |             |     |
| Foundation Alt  | 01            | Poured Conc.   |            |            |           | Dep % Ovr                       |      |             |            |             |     |
| Rms Prts  |               |                |            |            |           | Dep Ovr Comment                 |      |             |            |             |     |
| Bath Split  | 52            | 5 Full-2 Half  |            |            |           | Misc Imp Ovr                    |      |             |            |             |     |
|   |               |                |            |            |           | Misc Imp Ovr Comment            |      |             |            |             |     |
|   |               |                |            |            |           | Cost to Cure Ovr                |      |             |            |             |     |
|   |               |                |            |            |           | Cost to Cure Ovr Comment        |      |             |            |             |     |
| <b>OB - OUTBUILDING &amp; YARD ITEMS(L) / XF - BUILDING EXTRA FEATURES(B)</b> |               |                |            |            |           |                                 |      |             |            |             |     |
| Code  | Description   | L/B            | Units      | Unit Price | Yr Blt    | Cond. Cd                        | % Gd | Grade       | Grade Adj. | Appr. Value |     |
| FOP   | Open Porch-ro | B              | 303        | 55.00      | 1984      |                                 | 73   |             | 0.00       | 8,700       |     |
| <b>BUILDING SUB-AREA SUMMARY SECTION</b>                                      |               |                |            |            |           |                                 |      |             |            |             |     |
| Code  | Description   | Living Area    | Floor Area | Eff Area   | Unit Cost | Undeprec Value                  |      |             |            |             |     |
|   |               |                |            |            |           |                                 |      |             |            |             |     |
| Ttl Gross Liv / Lease Area  |               |                |            |            |           |                                 |      |             |            |             |     |

| CURRENT OWNER  |  | TOPO             |       | UTILITIES  |              | STRT / ROAD |       | LOCATION |            | CURRENT ASSESSMENT |      |           |           |
|--|--|------------------|-------|------------|--------------|-------------|-------|----------|------------|--------------------|------|-----------|-----------|
| JENKINS, JOSEPH R TR<br>SOUTH BLUFF REALTY TRUST OF 1<br>116 FLANDERS ROAD SUITE 1100<br><br>WESTBOROUG MA 01581 |  | 1                | Level | 6          | Septic       | 1           | Paved | 7        | Waterfront | Description        | Code | Assessed  | Assessed  |
|  |  |                  |       | 2          | Public Water |             |       | 1        | Excel View | RESIDNTL           | 1090 | 2,509,800 | 2,509,800 |
| <b>SUPPLEMENTAL DATA</b>   |  |                  |       |            |              |             |       |          |            | RES LAND           | 1090 | 5,336,600 | 5,336,600 |
| Alt Prcl ID  |  | Split Zonin      |       | Plan Ref.  |              | Land Ct#    |       | 15354-52 |            |                    |      |           |           |
| BID Parcel   |  | ResExpt Q        |       | #SR        |              | Life Estate |       | PP STATU |            |                    |      |           |           |
| #DL 1  |  | LOT 21           |       | Assoc Pid# |              |             |       |          |            |                    |      |           |           |
| #DL 2  |  |                  |       |            |              |             |       |          |            |                    |      |           |           |
| GIS ID   |  | F_952630_2684820 |       |            |              |             |       |          |            | Total              |      | 7,846,400 | 7,846,400 |

801  
 FY2024  
 BARNSTABLE, MA

**VISION**

| RECORD OF OWNERSHIP                                 |  | BK-VOL/PAGE |   | SALE DATE  |  | Q/U |   | V/I       |  | SALE PRIC |       | VC   |           | PREVIOUS ASSESSMENTS (HISTORY) |      |           |           |      |           |           |      |         |
|---|--|-------------|---|------------|--|-----|---|-----------|--|-----------|-------|------|-----------|--------------------------------|------|-----------|-----------|------|-----------|-----------|------|---------|
| JENKINS, JOSEPH R TR<br>PHEENEY, HERBERT S & PAMELA |  | C145119     | 0 | 07-09-1997 |  | Q   | I | 5,140,000 |  | 00        |       | Year | Code      | Assessed                       | Year | Code      | Assessed  | Year | Code      | Assessed  |      |         |
|   |  | C69522      | 0 | 01-05-1977 |  | U   |   | 0         |  |           |       | 2023 | 1090      | 2,173,400                      | 2022 | 1090      | 1,853,700 | 2021 | 1090      | 1,191,600 |      |         |
|   |  |             |   |            |  |     |   |           |  |           | 2023  | 1090 | 4,887,800 |                                | 1090 | 4,655,100 |           | 1090 | 4,389,100 |           | 1090 | 313,200 |
|   |  |             |   |            |  |     |   |           |  |           | Total |      | 7,061,200 | Total                          |      | 6,508,800 | Total     |      | 5,893,900 |           |      |         |

| EXEMPTIONS |      |             |        | OTHER ASSESSMENTS |             |        |        | This signature acknowledges a visit by a Data Collector or Assessor |  |  |  |  |  |  |  |  |  |  |  |
|------------|------|-------------|--------|-------------------|-------------|--------|--------|---|--|--|--|--|--|--|--|--|--|--|--|
| Year       | Code | Description | Amount | Code              | Description | Number | Amount | Comm Int  |  |  |  |  |  |  |  |  |  |  |  |
|            |      |             |        |                   |             |        |        |   |  |  |  |  |  |  |  |  |  |  |  |
| Total      |      |             | 0.00   |                   |             |        |        |   |  |  |  |  |  |  |  |  |  |  |  |

| ASSESSING NEIGHBORHOOD |           |   |         | APPRAISED VALUE SUMMARY |                               |  |  |           |
|------------------------|-----------|---|---------|-------------------------|-------------------------------|--|--|-----------|
| Nbhd                   | Nbhd Name | B | Tracing | Batch                   |                               |  |  |           |
| WF14                   |           |   |         | OSTVIL                  | Appraised Bldg. Value (Card)  |  |  | 2,089,500 |
|                        |           |   |         |                         | Appraised Xf (B) Value (Bldg) |  |  | 102,200   |
|                        |           |   |         |                         | Appraised Ob (B) Value (Bldg) |  |  | 318,100   |
|                        |           |   |         |                         | Appraised Land Value (Bldg)   |  |  | 5,336,600 |
|                        |           |   |         |                         | Special Land Value            |  |  | 0         |
|                        |           |   |         |                         | Total Appraised Parcel Value  |  |  | 7,846,400 |
|                        |           |   |         |                         | Valuation Method              |  |  | C         |
|                        |           |   |         |                         | Total Appraised Parcel Value  |  |  | 7,846,400 |

| NOTES     |            |      |             |        |           |        |           |          |      |    |      | VISIT / CHANGE HISTORY |    |                |  |  |  |
|-----------|------------|------|-------------|--------|-----------|--------|-----------|----------|------|----|------|------------------------|----|----------------|--|--|--|
| Permit Id | Issue Date | Type | Description | Amount | Insp Date | % Comp | Date Comp | Comments | Date | Id | Type | Is                     | Cd | Purpost/Result |  |  |  |
|           |            |      |             |        |           |        |           |          |      |    |      |                        |    |                |  |  |  |

| LAND LINE VALUATION SECTION |          |                 |      |    |            |            |           |         |            |       |       |           |        |                    |            |            |         |
|-----------------------------|----------|-----------------|------|----|------------|------------|-----------|---------|------------|-------|-------|-----------|--------|--------------------|------------|------------|---------|
| B                           | Use Code | Description     | Zone | LA | Land Units | Unit Price | Size Adj  | AC Disc | Site Index | Cond. | Nbhd. | Nbhd. Adj | Notes  | Location Adjustmen | Adj Unit P | Land Value |         |
| 2                           | 1090     | Multi Hses M-01 | RF-1 | 3  | 1.000      | AC         | 14,250.00 | 1.00000 | 1.0000     | 0     | 1.00  | WF14      | 28.000 |                    | 1.0000     | 399,000    | 399,000 |

|                       |  |  |  |  |      |    |                        |  |  |  |  |      |                  |  |  |  |  |         |
|-----------------------|--|--|--|--|------|----|------------------------|--|--|--|--|------|------------------|--|--|--|--|---------|
| Total Card Land Units |  |  |  |  | 1.00 | AC | Parcel Total Land Area |  |  |  |  | 2.00 | Total Land Value |  |  |  |  | 399,000 |
|-----------------------|--|--|--|--|------|----|------------------------|--|--|--|--|------|------------------|--|--|--|--|---------|

| CONSTRUCTION DETAIL |    |                | CONSTRUCTION DETAIL (CONTINUED) |    |             |
|---------------------|----|----------------|---------------------------------|----|-------------|
| Element             | Cd | Description    | Element                         | Cd | Description |
| Style               | 01 | Ranch          |                                 |    |             |
| Model               | 01 | Residential    |                                 |    |             |
| Grade:              | C+ | Average Plus   |                                 |    |             |
| Stories             | 1  | 1 Story        |                                 |    |             |
| Exterior Wall 1     | 08 | Wood on Sheath |                                 |    |             |
| Exterior Wall 2     |    |                |                                 |    |             |
| RooF Structure      | 03 | Gable/Hip      |                                 |    |             |
| RooF Cover          | 10 | Wood Shingle   |                                 |    |             |
| Interior Wall 1     | 05 | Drywall        |                                 |    |             |
| Interior Wall 2     |    |                |                                 |    |             |
| Interior Floor 1    | 12 | Hardwood       |                                 |    |             |
| Interior Floor 2    | 11 | Ceram Clay Til |                                 |    |             |
| Heat Fuel           | 08 | Propane        |                                 |    |             |
| Heat Type           | 04 | Hot Air        |                                 |    |             |
| AC Type             | 03 | Central        |                                 |    |             |
| Bedrooms            | 03 | 3 Bedrooms     |                                 |    |             |
| Full Baths          | 2  |                |                                 |    |             |
| Half Baths          | 0  |                |                                 |    |             |
| Extra Fixtures      |    |                |                                 |    |             |
| Total Rooms         | 5  | 5 Rooms        |                                 |    |             |
| Bath Style          |    |                |                                 |    |             |
| Kitchen Style       |    |                |                                 |    |             |
| Occupancy           |    |                |                                 |    |             |
| Usrflid 105         |    |                |                                 |    |             |
| Accessory Apt       |    |                |                                 |    |             |
| Foundation Alt      | 03 | Conc. Slab     |                                 |    |             |
| Rms Prts            |    |                |                                 |    |             |
| Bath Split          | 20 | 2 Full-0 Half  |                                 |    |             |

| CONDO DATA  |      |             |         |     |
|-------------|------|-------------|---------|-----|
| Parcel Id   |      | C           | Ownr    | 0.0 |
| Adjust Type | Code | Description | Factor% |     |
| Condo Flr   |      |             |         |     |
| Condo Unit  |      |             |         |     |

| COST / MARKET VALUATION  |         |
|--------------------------|---------|
| Building Value New       | 591,358 |
| Year Built               | 1998    |
| Effective Year Built     | 2005    |
| Depreciation Code        | A       |
| Remodel Rating           |         |
| Year Remodeled           |         |
| Depreciation %           | 11      |
| Functional Obsol         | 0       |
| External Obsol           | 0       |
| Trend Factor             | 1       |
| Condition                |         |
| Condition %              |         |
| Percent Good             | 89      |
| RCNLD                    | 526,300 |
| Dep % Ovr                |         |
| Dep Ovr Comment          |         |
| Misc Imp Ovr             |         |
| Misc Imp Ovr Comment     |         |
| Cost to Cure Ovr         |         |
| Cost to Cure Ovr Comment |         |

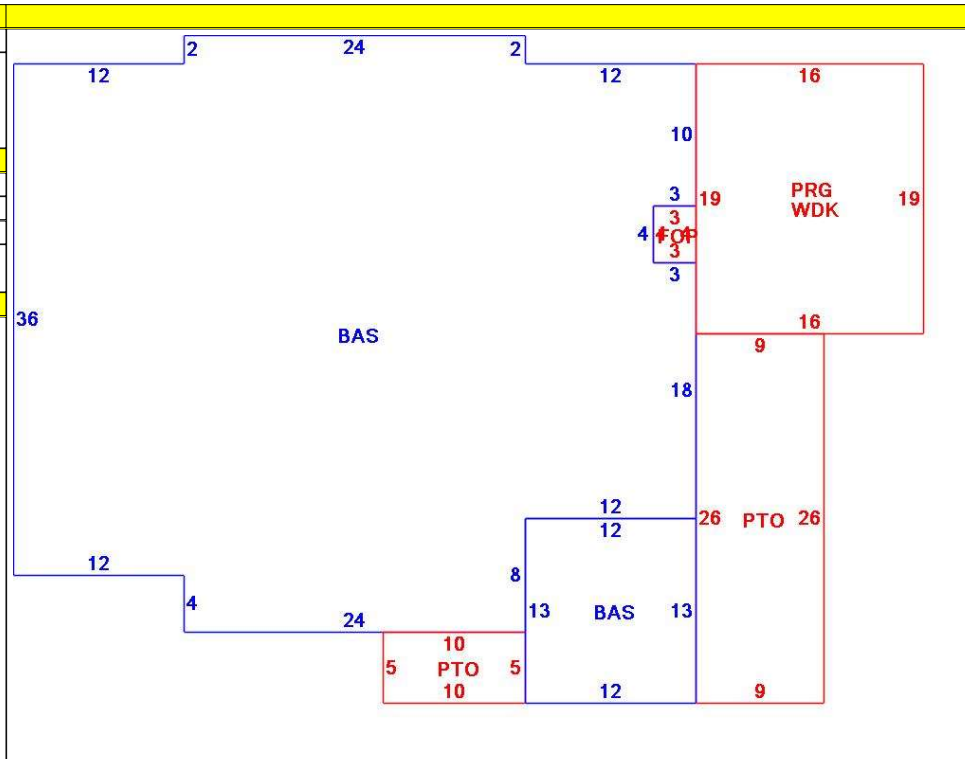

| OB - OUTBUILDING & YARD ITEMS(L) / XF - BUILDING EXTRA FEATURES(B) |                |     |       |            |        |          |      |       |            |             |
|--|----------------|-----|-------|------------|--------|----------|------|-------|------------|-------------|
| Code   | Description    | L/B | Units | Unit Price | Yr Blt | Cond. Cd | % Gd | Grade | Grade Adj. | Appr. Value |
| WDC  | Wood Deck w/   | L   | 304   | 18.00      | 2011   |          | 84   |       | 0.00       | 4,600       |
| PRG1   | Pergola-Avg    | L   | 304   | 18.00      | 2011   |          | 84   | C     | 1.00       | 4,600       |
| PAT1   | Patio- Average | L   | 50    | 5.89       | 2013   |          | 94   |       | 0.00       | 400         |
| PATF   | Flagstone Pav  | L   | 234   | 30.00      | 2013   |          | 94   |       | 0.00       | 7,000       |
| FOP  | Open Porch-ro  | B   | 12    | 55.00      | 2007   |          | 89   |       | 0.00       | 1,100       |

| BUILDING SUB-AREA SUMMARY SECTION |             |             |            |          |           |                |
|-----------------------------------|-------------|-------------|------------|----------|-----------|----------------|
| Code                              | Description | Living Area | Floor Area | Eff Area | Unit Cost | Undeprec Value |
| BAS                               | First Floor | 1,968       | 1,968      | 1,968    | 300.49    | 591,358        |
| FOP                               | Open Porch  | 0           | 12         | 0        | 0.00      | 0              |
| PRG                               | Pergola     | 0           | 304        | 0        | 0.00      | 0              |
| PTO                               | Patio       | 0           | 284        | 0        | 0.00      | 0              |
| WDK                               | Wood Deck   | 0           | 304        | 0        | 0.00      | 0              |
| Ttl Gross Liv / Lease Area        |             | 1,968       | 2,872      | 1,968    |           | 591,358        |

