

| CURRENT OWNER | | | | TOPO | UTILITIES | STRT / ROAD | LOCATION | CURRENT ASSESSMENT | | | | 801 FY2024 BARNSTABLE, MA VISION | | | | | | | |
|--|------------|----------------|---------------|--------------------------|------------------|-------------|------------------------|--------------------|-----------------------------|---------------------------------------|---|--|------------------|------------------|-----------------------|--------------|------------------------|------------------------|-------------|
| BAKER, JON M JR & HILLARY C 58 YALE STREET WINCHESTER MA 01890 | | | | 1 | Level | | 1 | Paved | Description | Code | Assessed | | | Assessed | RESIDNTL RES LAND | 1010 1010 | 2,154,200 2,157,100 | 2,154,200 2,157,100 | |
| | | | | SUPPLEMENTAL DATA | | | | | | | | | | Total | | | | | 4,311,300 |
| | | | | Alt Prcl ID | Split Zonin | BID Parcel | ResExpt Q | #DL 1 | LOT 228 | #DL 2 | GIS ID | | | F_954496_2688103 | Plan Ref. | Land Ct# | 15354-131 (SH 1) | #SR | Life Estate |
| RECORD OF OWNERSHIP | | | | BK-VOL/PAGE | SALE DATE | Q/U | V/I | SALE PRIC | VC | PREVIOUS ASSESSMENTS (HISTORY) | | | | | | | | | |
| BAKER, JON M JR & HILLARY C | | | | C205629 | 0 | 02-26-2015 | Q | I | 2,800,000 | 00 | Year | Code | Assessed | Year | Code | Assessed V | Year | Code | Assessed |
| LINDSEY, JEFFREY & ALYSON R | | | | C194286 | 0 | 05-18-2011 | Q | I | 2,650,000 | 00 | 2023 | 1010 | 1,868,300 | 2022 | 1010 | 1,542,200 | 2021 | 1010 | 1,251,400 |
| MINGLE, JAMES K & KATHLEEN L | | | | C160263 | 0 | 01-02-2001 | Q | I | 625,000 | 1P | | 1010 | 2,783,400 | | 1010 | 1,435,500 | | 1010 | 1,435,500 |
| DJAMOOS, JOSEPH E & THERESA L | | | | C154981 | 0 | 09-30-1999 | Q | V | 525,000 | 00 | | | | | | | | 1010 | 155,000 |
| SARNEY, GEORGE W | | | | C151428 | 0 | 12-24-1998 | Q | V | 390,000 | 1B | Total | | 4,651,700 | Total | | 2,977,700 | Total | | 2,841,900 |
| EXEMPTIONS | | | | OTHER ASSESSMENTS | | | | | | | This signature acknowledges a visit by a Data Collector or Assessor | | | | | | | | |
| Year | Code | Description | | Amount | Code | Description | | Number | Amount | Comm Int | APPRAISED VALUE SUMMARY | | | | | | | | |
| | | | | | | | | | | | Appraised Bldg. Value (Card) | | | | | | | 1,881,300 | |
| Total | | | | 0.00 | | | | | | | | Appraised Xf (B) Value (Bldg) | | | | | | | 117,900 |
| ASSESSING NEIGHBORHOOD | | | | | | | | | | | Appraised Ob (B) Value (Bldg) | | | | | | | 155,000 | |
| Nbhd | Nbhd Name | | | B | Tracing | | Batch | | Appraised Land Value (Bldg) | | | | | | | 2,157,100 | | | |
| 0118 | | | | | | | OSTVIL | | Special Land Value | | | | | | | 0 | | | |
| NOTES | | | | | | | | | | | Total Appraised Parcel Value | | | | | | | 4,311,300 | |
| | | | | | | | | | | | Valuation Method | | | | | | | C | |
| | | | | | | | | | | | Total Appraised Parcel Value | | | | | | | 4,311,300 | |
| BUILDING PERMIT RECORD | | | | | | | | | | VISIT / CHANGE HISTORY | | | | | | | | | |
| Permit Id | Issue Date | Type | Description | Amount | Insp Date | % Comp | Date Comp | Comments | | Date | Id | Type | Is | Cd | Purpost/Result | | | | |
| 201201431 | 03-21-2012 | OB | Out Building | 20,000 | 05-28-2014 | 100 | 06-30-2014 | POOL PAVILION | | 06-12-2020 | WD | | | 25 | NO TRESPASSING | | | | |
| 52353 | 03-23-2001 | DW | Dwelling | 735,020 | 01-31-2002 | 100 | 11-21-2002 | CO | | 08-09-2017 | MS | 02 | | 14 | Cyclical Inspection | | | | |
| 57034 | 05-01-2000 | SP | Swimming Pool | 46,000 | 04-15-2003 | 100 | 01-01-2003 | ALSO PHS | | 06-15-2016 | JR | 03 | | 20 | Sale Review | | | | |
| | | | | | | | | | | 06-30-2014 | MW | 01 | | 02 | Bldg Permit Completed | | | | |
| | | | | | | | | | | 02-21-2012 | RB | 03 | | 16 | In Office Review | | | | |
| | | | | | | | | | | 02-16-2012 | NF | 02 | | 20 | Sale Review | | | | |
| | | | | | | | | | | 01-31-2012 | JR | 03 | | 20 | Sale Review | | | | |
| LAND LINE VALUATION SECTION | | | | | | | | | | | | | | | | | | | |
| B | Use Code | Description | Zone | LA | Land Units | Unit Price | Size Adj | AC Disc | Site Index | Cond. | Nbhd. | Nbhd. Adj | Notes | | Location Adjustmen | Adj Unit P | Land Value | | |
| 1 | 1010 | Single Fam M-0 | RF-1 | 3 | 1.000 | AC | 176,344.00 | 1.00000 | 1.0000 | 5 | 1.00 | 0119 | 12.000 | | 1.0000 | 2,116,128 | 2,116,100 | | |
| 1 | 1010 | Single Fam M-0 | RF-1 | 3 | 0.240 | AC | 14,250.00 | 1.00000 | 1.0000 | 0 | 1.00 | 0119 | 12.000 | | 1.0000 | 171,000 | 41,000 | | |
| Total Card Land Units | | | | | 1.24 | AC | Parcel Total Land Area | | | | | 1.24 | Total Land Value | | | 2,157,100 | | | |

| CONSTRUCTION DETAIL | | | CONSTRUCTION DETAIL (CONTINUED) | | |
|---------------------|----|---------------|--------------------------------------|----|-------------|
| Element | Cd | Description | Element | Cd | Description |
| Style | 03 | Colonial | | | |
| Model | 01 | Residential | | | |
| Grade: | A | Luxury | | | |
| Stories | 2 | 2 Stories | | | |
| Exterior Wall 1 | 14 | Wood Shingle | | | |
| Exterior Wall 2 | | | | | |
| RooF Structure | 03 | Gable/Hip | | | |
| RooF Cover | 10 | Wood Shingle | | | |
| Interior Wall 1 | 05 | Drywall | | | |
| Interior Wall 2 | | | | | |
| Interior Floor 1 | 12 | Hardwood | | | |
| Interior Floor 2 | | | | | |
| Heat Fuel | 08 | Propane | | | |
| Heat Type | 04 | Hot Air | | | |
| AC Type | 03 | Central | | | |
| Bedrooms | 06 | 6 Bedrooms | | | |
| Full Baths | 5 | | | | |
| Half Baths | 1 | | | | |
| Extra Fixtures | | | | | |
| Total Rooms | 15 | 15 Rooms | | | |
| Bath Style | | | | | |
| Kitchen Style | | | | | |
| Occupancy | | | | | |
| UsrflD 105 | | | | | |
| Accessory Apt | | | | | |
| Foundation Alt | 01 | Poured Conc. | | | |
| Rms Prts | | | | | |
| Bath Split | 51 | 5 Full-1 Half | | | |
| | | | CONDO DATA | | |
| | | | Parcel Id | C | Owne 0.0 |
| | | | Adjust Type Code Description Factor% | | |
| | | | Condo Flr | | |
| | | | Condo Unit | | |
| | | | COST / MARKET VALUATION | | |
| | | | Building Value New | | 2,090,335 |
| | | | Year Built | | 2001 |
| | | | Effective Year Built | | 2006 |
| | | | Depreciation Code | | A |
| | | | Remodel Rating | | |
| | | | Year Remodeled | | |
| | | | Depreciation % | | 10 |
| | | | Functional Obsol | | 0 |
| | | | External Obsol | | 0 |
| | | | Trend Factor | | 1 |
| | | | Condition | | |
| | | | Condition % | | |
| | | | Percent Good | | 90 |
| | | | RCNLD | | 1,881,300 |
| | | | Dep % Ovr | | |
| | | | Dep Ovr Comment | | |
| | | | Misc Imp Ovr | | |
| | | | Misc Imp Ovr Comment | | |
| | | | Cost to Cure Ovr | | |
| | | | Cost to Cure Ovr Comment | | |

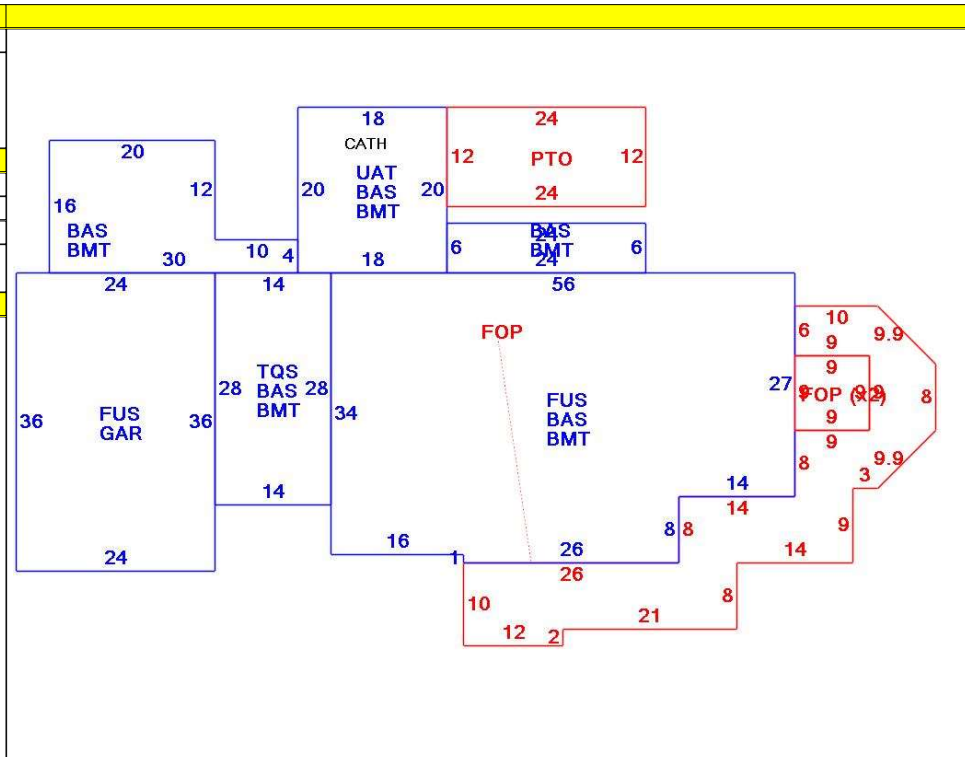

| OB - OUTBUILDING & YARD ITEMS(L) / XF - BUILDING EXTRA FEATURES(B) | | | | | | | | | | |
|--|-----------------|-----|-------|------------|--------|----------|------|-------|------------|-------------|
| Code | Description | L/B | Units | Unit Price | Yr Blt | Cond. Cd | % Gd | Grade | Grade Adj. | Appr. Value |
| FPL3 | Fireplace 2 sto | B | 1 | 7000.00 | 2008 | | 90 | | 0.00 | 6,300 |
| TEN | Tennis Court 7 | L | 7,200 | 6.84 | 2002 | | 66 | 00 | 1.00 | 32,500 |
| SPL3 | Pool Gunite | L | 960 | 75.00 | 2002 | | 66 | 00 | 1.00 | 46,000 |
| PHS1 | Pool Hs/Elect, | L | 224 | 90.00 | 2002 | | 83 | 00 | 1.00 | 16,700 |
| PAT2 | Patio-Good | L | 288 | 9.94 | 2006 | | 87 | | 0.00 | 2,500 |
| FOP | Open Porch-ro | B | 869 | 55.00 | 2008 | | 90 | | 0.00 | 28,900 |
| GAR | Attached Gara | B | 864 | 40.00 | 2008 | | 90 | | 0.00 | 24,900 |
| BMT | Basement-Unfi | B | 3,088 | 26.01 | 2008 | | 90 | | 0.00 | 57,800 |
| FNC5 | FENCE-10'CH | L | 175 | 34.35 | 2006 | | 74 | | 0.00 | 4,400 |
| PAT2 | Patio-Good | L | 1,714 | 9.94 | 2002 | | 83 | | 0.00 | 11,800 |

| BUILDING SUB-AREA SUMMARY SECTION | | | | | | |
|-----------------------------------|---------------------|-------------|------------|----------|-----------|----------------|
| Code | Description | Living Area | Floor Area | Eff Area | Unit Cost | Undeprec Value |
| BAS | First Floor | 3,088 | 3,088 | 3,088 | 344.09 | 1,062,544 |
| BMT | Basement Area | 0 | 3,088 | 0 | 0.00 | 0 |
| FOP | Open Porch | 0 | 869 | 0 | 0.00 | 0 |
| FUS | Upper Story | 2,696 | 2,696 | 2,696 | 344.09 | 927,661 |
| GAR | Attached Garage | 0 | 864 | 0 | 0.00 | 0 |
| PTO | Patio | 0 | 288 | 0 | 0.00 | 0 |
| TQS | Three Quarter Story | 255 | 392 | 255 | 223.83 | 87,742 |
| UAT | Attic, Unfinished | 0 | 360 | 36 | 34.41 | 12,387 |
| Ttl Gross Liv / Lease Area | | 6,039 | 11,645 | 6,075 | | 2,090,334 |



| CURRENT OWNER | | | TOPO | UTILITIES | STRT / ROAD | LOCATION | CURRENT ASSESSMENT | | | | |
|-----------------------------|--|--|--|-----------|-------------|----------|--------------------|------|-----------|-----------|--|
| BAKER, JON M JR & HILLARY C | | | 1 Level | | 1 Paved | | Description | Code | Assessed | Assessed | 801 FY2024 BARNSTABLE, MA VISION |
| 58 YALE STREET | | | SUPPLEMENTAL DATA | | | | RESIDNTL | 1010 | 2,154,200 | 2,154,200 | |
| WINCHESTER MA 01890 | | | Alt Prcl ID Split Zonin BID Parcel ResExpt Q #DL 1 LOT 228 #DL 2 GIS ID F_954496_2688103 | | | | RES LAND | 1010 | 2,157,100 | 2,157,100 | |
| | | | Plan Ref. Land Ct# 15354-131 (SH 1) #SR Life Estate PP STATU Assoc Pid# | | | | Total | | 4,311,300 | 4,311,300 | |

| RECORD OF OWNERSHIP | | | BK-VOL/PAGE | SALE DATE | Q/U | V/I | SALE PRIC | VC | PREVIOUS ASSESSMENTS (HISTORY) | | | | | | | | |
|---------------------|--|--|-------------|-----------|-----|-----|-----------|----|--------------------------------|------|-----------|-------|------|-----------|-------|------|-----------|
| | | | | | | | | | Year | Code | Assessed | Year | Code | Assessed | Year | Code | Assessed |
| | | | | | | | | | 2023 | 1010 | 1,868,300 | 2022 | 1010 | 1,542,200 | 2021 | 1010 | 1,251,400 |
| | | | | | | | | | | 1010 | 2,783,400 | | 1010 | 1,435,500 | | 1010 | 1,435,500 |
| | | | | | | | | | Total | | 4,651,700 | Total | | 2,977,700 | Total | | 2,841,900 |

| EXEMPTIONS | | | OTHER ASSESSMENTS | | | | This signature acknowledges a visit by a Data Collector or Assessor | | | | | | | | | | | |
|------------|------|-------------|-------------------|------|-------------|--------|---|----------|--------------------------------|--|--|--|--|-----------|--|--|--|--|
| Year | Code | Description | Amount | Code | Description | Number | Amount | Comm Int | | | | | | | | | | |
| | | | | | | | | | APPRAISED VALUE SUMMARY | | | | | | | | | |
| Total | | | | | | | | | Appraised Bldg. Value (Card) | | | | | 1,881,300 | | | | |
| | | | | | | | | | Appraised Xf (B) Value (Bldg) | | | | | 117,900 | | | | |
| | | | | | | | | | Appraised Ob (B) Value (Bldg) | | | | | 155,000 | | | | |
| | | | | | | | | | Appraised Land Value (Bldg) | | | | | 2,157,100 | | | | |
| | | | | | | | | | Special Land Value | | | | | 0 | | | | |
| | | | | | | | | | Total Appraised Parcel Value | | | | | 4,311,300 | | | | |
| | | | | | | | | | Valuation Method | | | | | C | | | | |
| | | | | | | | | | Total Appraised Parcel Value | | | | | 4,311,300 | | | | |

| BUILDING PERMIT RECORD | | | | | | | | | | VISIT / CHANGE HISTORY | | | | | |
|------------------------|------------|------|-------------|--------|-----------|--------|-----------|----------|--|------------------------|----|------|----|----|----------------|
| Permit Id | Issue Date | Type | Description | Amount | Insp Date | % Comp | Date Comp | Comments | | Date | Id | Type | Is | Cd | Purpost/Result |
| | | | | | | | | | | | | | | | |

| LAND LINE VALUATION SECTION | | | | | | | | | | | | | | | | |
|-----------------------------|----------|-------------|------|----|------------------------|------------|----------|---------|------------|------------------|-------|-----------|-------|--------------------|------------|------------|
| B | Use Code | Description | Zone | LA | Land Units | Unit Price | Size Adj | AC Disc | Site Index | Cond. | Nbhd. | Nbhd. Adj | Notes | Location Adjustmen | Adj Unit P | Land Value |
| | | | | | | | | | | | | | | | | |
| Total Card Land Units | | | | | Parcel Total Land Area | | | | | Total Land Value | | | | | | |

| CONSTRUCTION DETAIL | | | | | | CONSTRUCTION DETAIL (CONTINUED) | | | | | |
|---|----------------|---------------|------------|------------|-----------|---------------------------------|------|-------------|------------|-------------|-----|
| Element | Cd | Description | | | | Element | Cd | Description | | | |
| Style | 03 | Colonial | | | | | | | | | |
| Model | 01 | Residential | | | | | | | | | |
| Grade: | A | Luxury | | | | | | | | | |
| Stories | 2 | 2 Stories | | | | | | | | | |
| Exterior Wall 1 | 14 | Wood Shingle | | | | CONDO DATA | | | | | |
| Exterior Wall 2 | | | | | | Parcel Id | | C | | Owne | 0.0 |
| Roof Structure | 03 | Gable/Hip | | | | | | B | | S | |
| Roof Cover | 10 | Wood Shingle | | | | Adjust Type | Code | Description | | Factor% | |
| Interior Wall 1 | 05 | Drywall | | | | Condo Flr | | | | | |
| Interior Wall 2 | | | | | | Condo Unit | | | | | |
| Interior Floor 1 | 12 | Hardwood | | | | COST / MARKET VALUATION | | | | | |
| Interior Floor 2 | | | | | | Building Value New | | | | | |
| Heat Fuel | 08 | Propane | | | | Year Built | | | | | |
| Heat Type | 04 | Hot Air | | | | Effective Year Built | | | | | |
| AC Type | 03 | Central | | | | Depreciation Code | | | | | |
| Bedrooms | 06 | 6 Bedrooms | | | | Remodel Rating | | | | | |
| Full Baths | 5 | | | | | Year Remodeled | | | | | |
| Half Baths | 1 | | | | | Depreciation % | | | | | |
| Extra Fixtures | | | | | | Functional Obsol | | | | | |
| Total Rooms | 15 | 15 Rooms | | | | External Obsol | | | | | |
| Bath Style | | | | | | Trend Factor | | | | | |
| Kitchen Style | | | | | | Condition | | | | | |
| Occupancy | | | | | | Condition % | | | | | |
| Usrflid 105 | | | | | | Percent Good | | | | | |
| Accessory Apt | | | | | | RCNLD | | | | | |
| Foundation Alt | 01 | Poured Conc. | | | | Dep % Ovr | | | | | |
| Rms Prts | | | | | | Dep Ovr Comment | | | | | |
| Bath Split | 51 | 5 Full-1 Half | | | | Misc Imp Ovr | | | | | |
| | | | | | | Misc Imp Ovr Comment | | | | | |
| | | | | | | Cost to Cure Ovr | | | | | |
| | | | | | | Cost to Cure Ovr Comment | | | | | |
| OB - OUTBUILDING & YARD ITEMS(L) / XF - BUILDING EXTRA FEATURES(B) | | | | | | | | | | | |
| Code | Description | L/B | Units | Unit Price | Yr Blt | Cond. Cd | % Gd | Grade | Grade Adj. | Appr. Value | |
| SPH3 | Pool Heater 80 | L | 1 | 4116.00 | 2002 | | 66 | | 0.00 | 2,700 | |
| SPC1 | Pool Cover-Au | L | 960 | 17.53 | 2002 | | 66 | | 0.00 | 11,100 | |
| SPDC | POOL DECK | L | 1,714 | 5.61 | 2002 | | 66 | | 0.00 | 6,300 | |
| CBN1 | Cabana-Avg | L | 390 | 81.58 | 2002 | | 66 | C | 1.00 | 21,000 | |
| BUILDING SUB-AREA SUMMARY SECTION | | | | | | | | | | | |
| Code | Description | Living Area | Floor Area | Eff Area | Unit Cost | Undeprec Value | | | | | |
| | | | | | | | | | | | |
| Ttl Gross Liv / Lease Area | | | | | | | | | | | |