

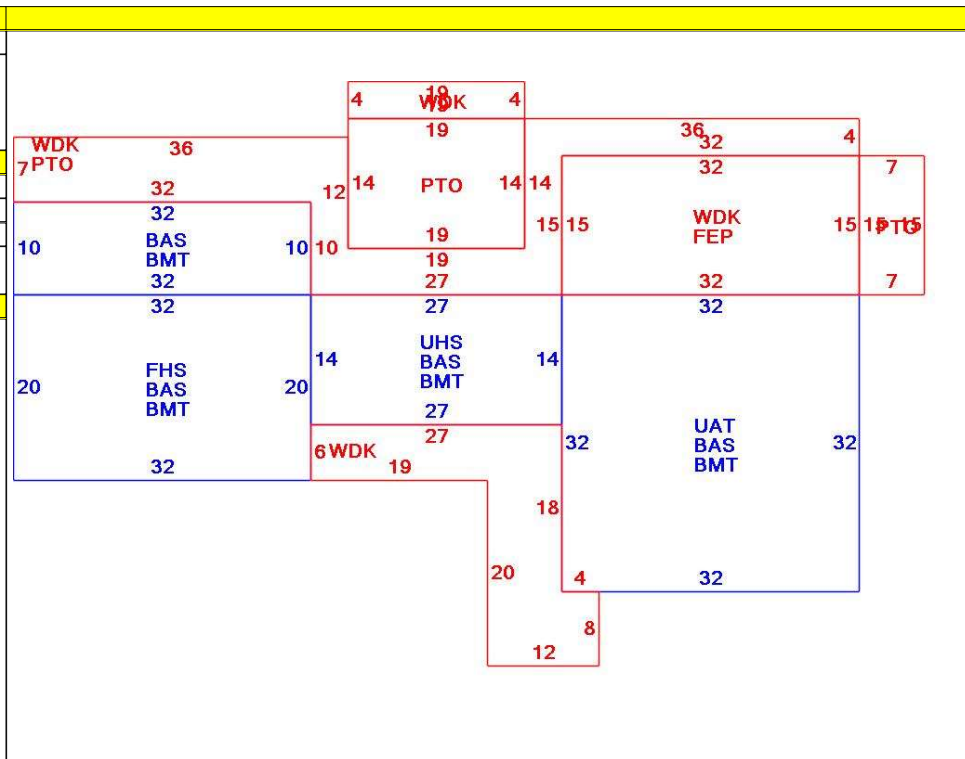

CONSTRUCTION DETAIL			CONSTRUCTION DETAIL (CONTINUED)		
Element	Cd	Description	Element	Cd	Description
Style	07	Modern/Contemp			
Model	01	Residential			
Grade:	A	Luxury			
Stories	1.5	1 1/2 Stories			
Exterior Wall 1	08	Wood on Sheath			
Exterior Wall 2					
RooF Structure	03	Gable/Hip			
RooF Cover	03	Asph/F Gls/Cmp			
Interior Wall 1	03	Plastered			
Interior Wall 2					
Interior Floor 1	14	Carpet			
Interior Floor 2					
Heat Fuel	03	Gas			
Heat Type	05	Hot Water			
AC Type	03	Central			
Bedrooms	06	6 Bedrooms			
Full Baths	4				
Half Baths	1				
Extra Fixtures					
Total Rooms	12	12 Rooms			
Bath Style					
Kitchen Style					
Occupancy					
Usrflid 105					
Accessory Apt					
Foundation Alt	01	Poured Conc.			
Rms Prts					
Bath Split	41	4 Full-1 Half			

CONDO DATA			
Parcel Id	C	B	S
Adjust Type	Code	Description	Factor%
Condo Flr			
Condo Unit			

COST / MARKET VALUATION	
Building Value New	1,194,352
Year Built	1971
Effective Year Built	1991
Depreciation Code	A
Remodel Rating	
Year Remodeled	
Depreciation %	22
Functional Obsol	0
External Obsol	0
Trend Factor	1
Condition	
Condition %	
Percent Good	78
RCNLD	931,600
Dep % Ovr	
Dep Ovr Comment	
Misc Imp Ovr	
Misc Imp Ovr Comment	
Cost to Cure Ovr	
Cost to Cure Ovr Comment	



OB - OUTBUILDING & YARD ITEMS(L) / XF - BUILDING EXTRA FEATURES(B)										
Code	Description	L/B	Units	Unit Price	Yr Blt	Cond. Cd	% Gd	Grade	Grade Adj.	Appr. Value
BGR2	2 Stall Bmt Ga	B	1	3244.00	1993		78		0.00	2,500
DKAV	Dock-Ave	L	1	100000.0	1993		48		0.00	48,000
BFA	Bsmt Fin-Avg	B	1,400	17.36	1993		78		0.00	19,000
WDC	Wood Decking	L	1,501	20.00	1996		54		0.00	14,300
FEP	Enclosed porc	B	480	70.00	1993		78		0.00	19,900
BMT	Basement-Unfi	B	2,362	26.01	1993		78		0.00	39,700
PATC	Conc Pavers	L	857	15.46	1996		77		0.00	9,300
PAT2	Patio-Good	L	105	9.94	2017		98		0.00	1,200
SHD2	Shed w/Elec	L	120	26.00	2017		96		0.00	3,000

BUILDING SUB-AREA SUMMARY SECTION						
Code	Description	Living Area	Floor Area	Eff Area	Unit Cost	Undeprec Value
BAS	First Floor	2,362	2,362	2,362	412.27	973,786
BMT	Basement Area	0	2,362	0	0.00	0
FEP	Enclosed Porch	0	480	0	0.00	0
FHS	Half Story	320	640	320	206.14	131,927
PTO	Patio	0	962	0	0.00	0
UAT	Attic, Unfinished	0	1,024	102	41.07	42,052
UHS	Half Story, Unfinished	0	378	113	123.25	46,587
WDK	Wood Deck	0	1,501	0	0.00	0
Ttl Gross Liv / Lease Area		2,682	9,709	2,897		1,194,352

