

| CURRENT OWNER                                                                  |  | TOPO           | UTILITIES      | STRT / ROAD | LOCATION          | CURRENT ASSESSMENT |      |           |           | 801<br>FY2024<br>BARNSTABLE, MA<br><br><b>VISION</b> |           |
|--------------------------------------------------------------------------------|--|----------------|----------------|-------------|-------------------|--------------------|------|-----------|-----------|------------------------------------------------------|-----------|
| POZEN, JEREMY & HEATHER<br><br>61 MONTVALE CRESENT<br><br>NEWTON MA 02459-2075 |  | 2 Above Street | 2 Public Water | 1 Paved     | 1 Water View      | Description        | Code | Assessed  | Assessed  |                                                      |           |
|                                                                                |  | 4 Gas          |                |             |                   | RESIDNTL           | 1090 | 1,661,700 | 1,661,700 |                                                      |           |
|                                                                                |  | 6 Septic       |                |             |                   | RES LAND           | 1090 | 1,209,200 | 1,209,200 |                                                      |           |
| <b>SUPPLEMENTAL DATA</b>                                                       |  |                |                |             |                   | Total              |      |           |           | 2,870,900                                            | 2,870,900 |
| Alt Prcl ID                                                                    |  | Split Zonin    |                |             | Plan Ref.         |                    |      |           |           |                                                      |           |
| BID Parcel                                                                     |  | ResExpt Q      |                |             | Land Ct# 11542-W  |                    |      |           |           |                                                      |           |
| #DL 1 LOT 32 & 32A                                                             |  |                |                |             | #SR               |                    |      |           |           |                                                      |           |
| #DL 2                                                                          |  |                |                |             | Life Estate       |                    |      |           |           |                                                      |           |
| GIS ID F_944197_2680198                                                        |  |                |                |             | PP STATU A:Active |                    |      |           |           |                                                      |           |
|                                                                                |  |                |                |             | Assoc Pid#        |                    |      |           |           |                                                      |           |

| RECORD OF OWNERSHIP |      | BK-VOL/PAGE | SALE DATE | Q/U  | V/I       | SALE PRIC | VC   | PREVIOUS ASSESSMENTS (HISTORY) |      |      |          |  |  |
|---------------------|------|-------------|-----------|------|-----------|-----------|------|--------------------------------|------|------|----------|--|--|
| Year                | Code | Assessed    | Year      | Code | Assessed  | Year      | Code | Assessed                       | Year | Code | Assessed |  |  |
| 2023                | 1090 | 1,286,500   | 2022      | 1090 | 1,102,100 | 2021      | 1090 | 936,200                        |      |      |          |  |  |
|                     | 1090 | 1,105,000   |           | 1090 | 610,100   |           | 1090 | 590,900                        |      |      |          |  |  |
|                     |      |             |           |      |           |           | 1090 | 23,200                         |      |      |          |  |  |
| Total               |      | 2,391,500   | Total     |      | 1,712,200 | Total     |      | 1,550,300                      |      |      |          |  |  |

| EXEMPTIONS |      |             | OTHER ASSESSMENTS |      |             |        | This signature acknowledges a visit by a Data Collector or Assessor |          |  |  |  |  |
|------------|------|-------------|-------------------|------|-------------|--------|---------------------------------------------------------------------|----------|--|--|--|--|
| Year       | Code | Description | Amount            | Code | Description | Number | Amount                                                              | Comm Int |  |  |  |  |
| Total      |      |             | 0.00              |      |             |        |                                                                     |          |  |  |  |  |

| ASSESSING NEIGHBORHOOD |           |   |         | APPRAISED VALUE SUMMARY |                               |           |  |
|------------------------|-----------|---|---------|-------------------------|-------------------------------|-----------|--|
| Nbhd                   | Nbhd Name | B | Tracing | Batch                   |                               |           |  |
| 0114                   |           |   | COTUIT  |                         | Appraised Bldg. Value (Card)  | 1,583,700 |  |
|                        |           |   |         |                         | Appraised Xf (B) Value (Bldg) | 52,000    |  |
|                        |           |   |         |                         | Appraised Ob (B) Value (Bldg) | 26,000    |  |
|                        |           |   |         |                         | Appraised Land Value (Bldg)   | 1,209,200 |  |
|                        |           |   |         |                         | Special Land Value            | 0         |  |
|                        |           |   |         |                         | Total Appraised Parcel Value  | 2,870,900 |  |
|                        |           |   |         |                         | Valuation Method              | C         |  |
|                        |           |   |         |                         | Total Appraised Parcel Value  | 2,870,900 |  |

| NOTES     |            |      |             |         |            |        |            |               | VISIT / CHANGE HISTORY |    |      |    |    |                            |
|-----------|------------|------|-------------|---------|------------|--------|------------|---------------|------------------------|----|------|----|----|----------------------------|
| Permit Id | Issue Date | Type | Description | Amount  | Insp Date  | % Comp | Date Comp  | Comments      | Date                   | Id | Type | Is | Cd | Purpost/Result             |
| 47516     | 07-19-2000 | DW   | Dwelling    | 75,000  | 12-07-2000 | 100    | 01-01-2001 | BLDG 2        | 10-07-2022             | SR | 02   |    | 03 | Cycl Insp Comp             |
| 26648     | 10-29-1997 | RE   | Remodel     | 175,000 | 01-01-1999 | 100    | 01-01-1999 | 2 STORY ADD'N | 06-04-2020             | DM |      |    | FR | Field Review               |
| B28623    | 11-01-1985 | AD   | Addition    | 85,000  | 01-15-1987 | 100    | 06-30-1987 | CO ADD'N      | 12-19-2012             | RB | 03   |    | 03 | Cycl Insp Comp             |
|           |            |      |             |         |            |        |            |               | 10-04-2012             | RB | 03   |    | 16 | In Office Review           |
|           |            |      |             |         |            |        |            |               | 02-09-2005             | PT | 02   |    | 01 | Meas/Est                   |
|           |            |      |             |         |            |        |            |               | 08-21-2002             | PT | 02   |    | 01 | Meas/Est                   |
|           |            |      |             |         |            |        |            |               | 11-16-1999             | PT | 01   |    | 00 | Meas/Listed-Interior Acces |

| LAND LINE VALUATION SECTION |          |                 |      |    |            |            |                        |         |            |       |       |           |                  |                    |            |            |           |
|-----------------------------|----------|-----------------|------|----|------------|------------|------------------------|---------|------------|-------|-------|-----------|------------------|--------------------|------------|------------|-----------|
| B                           | Use Code | Description     | Zone | LA | Land Units | Unit Price | Size Adj               | AC Disc | Site Index | Cond. | Nbhd. | Nbhd. Adj | Notes            | Location Adjustmen | Adj Unit P | Land Value |           |
| 1                           | 1090     | Multi Hses M-01 | RF   | 2  | 1.000      | AC         | 176,344.00             | 1.00000 | 1.0000     | 5     | 1.00  | 0114      | 6.500            |                    | 1.0000     | 1,146,236  | 1,146,200 |
| Total Card Land Units       |          |                 |      |    | 1.00       | AC         | Parcel Total Land Area |         |            |       |       | 1.68      | Total Land Value |                    |            | 1,146,200  |           |

| CONSTRUCTION DETAIL |    |                | CONSTRUCTION DETAIL (CONTINUED)      |    |             |
|---------------------|----|----------------|--------------------------------------|----|-------------|
| Element             | Cd | Description    | Element                              | Cd | Description |
| Style               | 07 | Modern/Contemp |                                      |    |             |
| Model               | 01 | Residential    |                                      |    |             |
| Grade:              | A  | Luxury         |                                      |    |             |
| Stories             | 2  | 2 Stories      |                                      |    |             |
| Exterior Wall 1     | 14 | Wood Shingle   |                                      |    |             |
| Exterior Wall 2     |    |                |                                      |    |             |
| Roof Structure      | 02 | Shed           |                                      |    |             |
| Roof Cover          | 03 | Asph/F Gls/Cmp |                                      |    |             |
| Interior Wall 1     | 05 | Drywall        |                                      |    |             |
| Interior Wall 2     |    |                |                                      |    |             |
| Interior Floor 1    | 12 | Hardwood       |                                      |    |             |
| Interior Floor 2    | 14 | Carpet         |                                      |    |             |
| Heat Fuel           | 03 | Gas            |                                      |    |             |
| Heat Type           | 04 | Hot Air        |                                      |    |             |
| AC Type             | 03 | Central        |                                      |    |             |
| Bedrooms            | 05 | 5 Bedrooms     |                                      |    |             |
| Full Baths          | 4  |                |                                      |    |             |
| Half Baths          | 1  |                |                                      |    |             |
| Extra Fixtures      |    |                |                                      |    |             |
| Total Rooms         | 10 | 10 Rooms       |                                      |    |             |
| Bath Style          |    |                |                                      |    |             |
| Kitchen Style       |    |                |                                      |    |             |
| Occupancy           |    |                |                                      |    |             |
| Usrflid 105         | 2  |                |                                      |    |             |
| Accessory Apt       |    |                |                                      |    |             |
| Foundation Alt      | 01 | Poured Conc.   |                                      |    |             |
| Rms Prts            |    |                |                                      |    |             |
| Bath Split          | 41 | 4 Full-1 Half  |                                      |    |             |
|                     |    |                | <b>CONDO DATA</b>                    |    |             |
|                     |    |                | Parcel Id                            | C  | Owne 0.0    |
|                     |    |                | Adjust Type Code Description Factor% |    |             |
|                     |    |                | Condo Flr                            |    |             |
|                     |    |                | Condo Unit                           |    |             |
|                     |    |                | <b>COST / MARKET VALUATION</b>       |    |             |
|                     |    |                | Building Value New                   |    | 1,518,991   |
|                     |    |                | Year Built                           |    | 1965        |
|                     |    |                | Effective Year Built                 |    | 2008        |
|                     |    |                | Depreciation Code                    |    | E           |
|                     |    |                | Remodel Rating                       |    |             |
|                     |    |                | Year Remodeled                       |    |             |
|                     |    |                | Depreciation %                       |    | 9           |
|                     |    |                | Functional Obsol                     |    | 0           |
|                     |    |                | External Obsol                       |    | 0           |
|                     |    |                | Trend Factor                         |    | 1           |
|                     |    |                | Condition                            |    |             |
|                     |    |                | Condition %                          |    | 91          |
|                     |    |                | Percent Good                         |    |             |
|                     |    |                | RCNLD                                |    | 1,382,300   |
|                     |    |                | Dep % Ovr                            |    |             |
|                     |    |                | Dep Ovr Comment                      |    |             |
|                     |    |                | Misc Imp Ovr                         |    |             |
|                     |    |                | Misc Imp Ovr Comment                 |    |             |
|                     |    |                | Cost to Cure Ovr                     |    |             |
|                     |    |                | Cost to Cure Ovr Comment             |    |             |

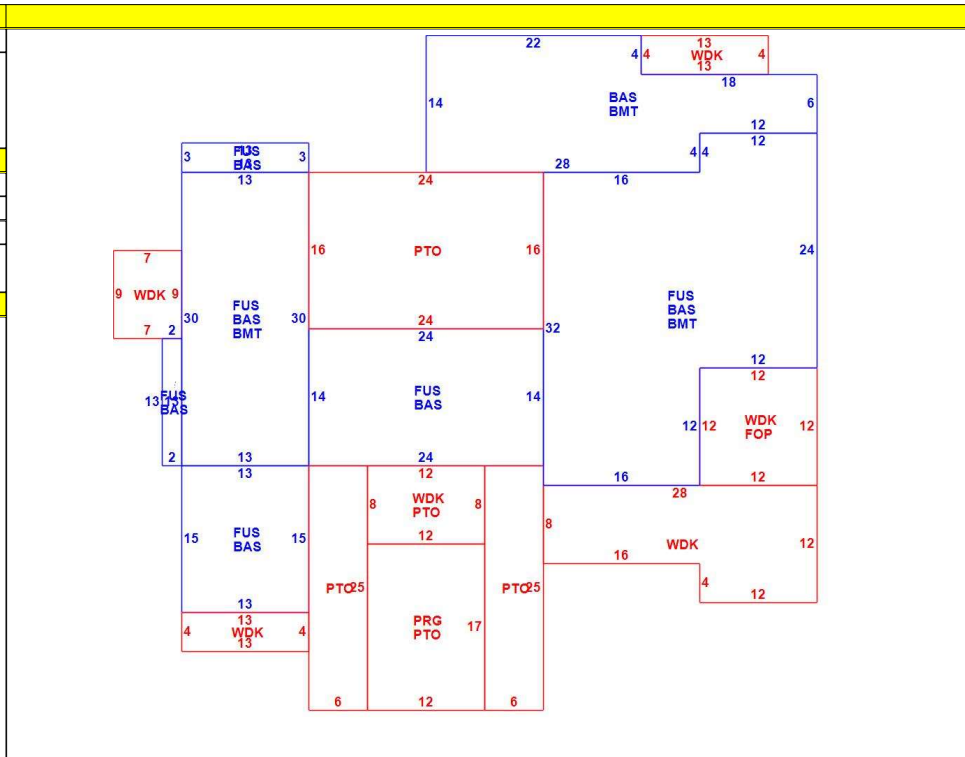

| OB - OUTBUILDING & YARD ITEMS(L) / XF - BUILDING EXTRA FEATURES(B) |                 |     |       |            |        |          |      |       |            |             |
|--------------------------------------------------------------------|-----------------|-----|-------|------------|--------|----------|------|-------|------------|-------------|
| Code                                                               | Description     | L/B | Units | Unit Price | Yr Blt | Cond. Cd | % Gd | Grade | Grade Adj. | Appr. Value |
| FPL1                                                               | Fireplace 1 sto | B   | 1     | 5000.00    | 2010   |          | 91   |       | 0.00       | 4,600       |
| SHD2                                                               | Shed w/Elec     | L   | 144   | 26.00      | 1990   |          | 42   |       | 0.00       | 1,600       |
| WDC                                                                | Wood Decking    | L   | 679   | 20.00      | 2007   |          | 76   |       | 0.00       | 9,500       |
| PATC                                                               | Conc Pavers     | L   | 984   | 15.46      | 2007   |          | 88   |       | 0.00       | 12,100      |
| FOP                                                                | Open Porch-ro   | B   | 144   | 55.00      | 2010   |          | 91   |       | 0.00       | 6,500       |
| BMT                                                                | Basement-Unfi   | B   | 1,630 | 26.01      | 2010   |          | 91   |       | 0.00       | 34,300      |
| PRG1                                                               | Pergola-Avg     | L   | 204   | 18.00      | 2007   |          | 76   | C     | 1.00       | 2,800       |

| BUILDING SUB-AREA SUMMARY SECTION |               |             |            |          |           |                |
|-----------------------------------|---------------|-------------|------------|----------|-----------|----------------|
| Code                              | Description   | Living Area | Floor Area | Eff Area | Unit Cost | Undeprec Value |
| BAS                               | First Floor   | 2,226       | 2,226      | 2,226    | 378.61    | 842,790        |
| BMT                               | Basement Area | 0           | 1,630      | 0        | 0.00      | 0              |
| FOP                               | Open Porch    | 0           | 144        | 0        | 0.00      | 0              |
| FUS                               | Upper Story   | 1,786       | 1,786      | 1,786    | 378.61    | 676,201        |
| PRG                               | Pergola       | 0           | 204        | 0        | 0.00      | 0              |
| PTO                               | Patio         | 0           | 984        | 0        | 0.00      | 0              |
| WDK                               | Wood Deck     | 0           | 679        | 0        | 0.00      | 0              |
| Ttl Gross Liv / Lease Area        |               | 4,012       | 7,653      | 4,012    |           | 1,518,991      |



| CURRENT OWNER                                                                                                   |  | TOPO | UTILITIES    | STRT / ROAD                                                                            | LOCATION   | CURRENT ASSESSMENT |      |           |           | 801<br>FY2024<br>BARNSTABLE, MA<br><br><b>VISION</b> |           |
|-----------------------------------------------------------------------------------------------------------------|--|------|--------------|----------------------------------------------------------------------------------------|------------|--------------------|------|-----------|-----------|------------------------------------------------------|-----------|
| POZEN, JEREMY & HEATHER<br><br>61 MONTVALE CRESENT<br><br>NEWTON MA 02459-2075                                  |  | 2    | Public Water | 1                                                                                      | Water View | Description        | Code | Assessed  | Assessed  |                                                      |           |
|                                                                                                                 |  | 4    | Gas          | 1                                                                                      | Paved      | RESIDNTL           | 1090 | 1,661,700 | 1,661,700 |                                                      |           |
|                                                                                                                 |  | 6    | Septic       |                                                                                        |            | RES LAND           | 1090 | 1,209,200 | 1,209,200 |                                                      |           |
| SUPPLEMENTAL DATA                                                                                               |  |      |              |                                                                                        |            | Total              |      |           |           | 2,870,900                                            | 2,870,900 |
| Alt Prcl ID<br>Split Zonin<br>BID Parcel<br>ResExpt Q<br>#DL 1 LOT 32 & 32A<br>#DL 2<br>GIS ID F_944197_2680198 |  |      |              | Plan Ref.<br>Land Ct# 11542-W<br>#SR<br>Life Estate<br>PP STATU A:Active<br>Assoc Pid# |            |                    |      |           |           |                                                      |           |

| RECORD OF OWNERSHIP               |         | BK-VOL/PAGE | SALE DATE  | Q/U  | V/I      | SALE PRIC | VC   | PREVIOUS ASSESSMENTS (HISTORY) |       |           |          |           |           |          |      |         |
|-----------------------------------|---------|-------------|------------|------|----------|-----------|------|--------------------------------|-------|-----------|----------|-----------|-----------|----------|------|---------|
| Year                              | Code    | Assessed    | Year       | Code | Assessed | Year      | Code | Assessed                       | Year  | Code      | Assessed | Year      | Code      | Assessed |      |         |
| POZEN, JEREMY & HEATHER           | C197237 | 0           | 05-31-2012 | U    | I        | 1,400,000 | 1A   | 2023                           | 1090  | 1,286,500 | 2022     | 1090      | 1,102,100 | 2021     | 1090 | 936,200 |
| POZEN, ROBERT C & ELIZABETH K TRS | C149893 | 0           | 08-28-1998 | U    | I        | 1         | 1A   |                                | 1090  | 1,105,000 |          | 1090      | 610,100   |          | 1090 | 590,900 |
| POZEN, ROBERT C & ELIZABETH K     | C145486 | 0           | 08-15-1997 | Q    | I        | 650,000   | 1    |                                |       |           |          |           |           |          | 1090 | 23,200  |
| DIGGINS, MARGARET M               | C105431 | 0           | 02-15-1986 | U    | I        | 1         | B    | Total                          |       |           |          |           |           |          |      |         |
| DIGGINS, JAMES P                  | C103997 | 0           | 10-15-1985 | U    | I        | 1         | B    | 2,391,500                      | Total | 1,712,200 | Total    | 1,550,300 |           |          |      |         |

| EXEMPTIONS |      |             | OTHER ASSESSMENTS |      |             |        | This signature acknowledges a visit by a Data Collector or Assessor |          |  |  |  |  |  |  |
|------------|------|-------------|-------------------|------|-------------|--------|---------------------------------------------------------------------|----------|--|--|--|--|--|--|
| Year       | Code | Description | Amount            | Code | Description | Number | Amount                                                              | Comm Int |  |  |  |  |  |  |
| Total      |      |             | 0.00              |      |             |        |                                                                     |          |  |  |  |  |  |  |

| ASSESSING NEIGHBORHOOD |           |   |         |        |                               | APPRAISED VALUE SUMMARY |  |  |  |  |           |
|------------------------|-----------|---|---------|--------|-------------------------------|-------------------------|--|--|--|--|-----------|
| Nbhd                   | Nbhd Name | B | Tracing | Batch  |                               |                         |  |  |  |  |           |
| 0114                   |           |   |         | COTUIT | Appraised Bldg. Value (Card)  |                         |  |  |  |  | 1,583,700 |
|                        |           |   |         |        | Appraised Xf (B) Value (Bldg) |                         |  |  |  |  | 52,000    |
|                        |           |   |         |        | Appraised Ob (B) Value (Bldg) |                         |  |  |  |  | 26,000    |
|                        |           |   |         |        | Appraised Land Value (Bldg)   |                         |  |  |  |  | 1,209,200 |
|                        |           |   |         |        | Special Land Value            |                         |  |  |  |  | 0         |
|                        |           |   |         |        | Total Appraised Parcel Value  |                         |  |  |  |  | 2,870,900 |
|                        |           |   |         |        | Valuation Method              |                         |  |  |  |  | C         |
|                        |           |   |         |        | Total Appraised Parcel Value  |                         |  |  |  |  | 2,870,900 |

| NOTES     |            |      |             |        |           |        |           |          |      |    | VISIT / CHANGE HISTORY |    |    |                |  |  |
|-----------|------------|------|-------------|--------|-----------|--------|-----------|----------|------|----|------------------------|----|----|----------------|--|--|
| Permit Id | Issue Date | Type | Description | Amount | Insp Date | % Comp | Date Comp | Comments | Date | Id | Type                   | Is | Cd | Purpost/Result |  |  |
|           |            |      |             |        |           |        |           |          |      |    |                        |    |    |                |  |  |

| LAND LINE VALUATION SECTION |          |                 |      |    |            |            |                        |         |            |       |       |           |                  |                    |            |            |        |
|-----------------------------|----------|-----------------|------|----|------------|------------|------------------------|---------|------------|-------|-------|-----------|------------------|--------------------|------------|------------|--------|
| B                           | Use Code | Description     | Zone | LA | Land Units | Unit Price | Size Adj               | AC Disc | Site Index | Cond. | Nbhd. | Nbhd. Adj | Notes            | Location Adjustmen | Adj Unit P | Land Value |        |
| 2                           | 1090     | Multi Hses M-01 | RF   | 2  | 0.680      | AC         | 14,250.00              | 1.00000 | 1.0000     | 0     | 1.00  | 0114      | 6.500            |                    | 1.0000     | 92,625     | 63,000 |
| Total Card Land Units       |          |                 |      |    | 0.68       | AC         | Parcel Total Land Area |         |            |       |       | 1.68      | Total Land Value |                    |            |            | 63,000 |



| CONSTRUCTION DETAIL |    |                | CONSTRUCTION DETAIL (CONTINUED) |    |             |
|---------------------|----|----------------|---------------------------------|----|-------------|
| Element             | Cd | Description    | Element                         | Cd | Description |
| Style               | 07 | Modern/Contemp |                                 |    |             |
| Model               | 01 | Residential    |                                 |    |             |
| Grade:              | C+ | Average Plus   |                                 |    |             |
| Stories             | 1  | 1 Story        |                                 |    |             |
| Exterior Wall 1     | 14 | Wood Shingle   |                                 |    |             |
| Exterior Wall 2     |    |                |                                 |    |             |
| RooF Structure      | 03 | Gable/Hip      |                                 |    |             |
| RooF Cover          | 03 | Asph/F Gls/Cmp |                                 |    |             |
| Interior Wall 1     | 05 | Drywall        |                                 |    |             |
| Interior Wall 2     |    |                |                                 |    |             |
| Interior Floor 1    | 12 | Hardwood       |                                 |    |             |
| Interior Floor 2    |    |                |                                 |    |             |
| Heat Fuel           | 03 | Gas            |                                 |    |             |
| Heat Type           | 04 | Hot Air        |                                 |    |             |
| AC Type             | 03 | Central        |                                 |    |             |
| Bedrooms            | 01 | 1 Bedroom      |                                 |    |             |
| Full Baths          | 1  |                |                                 |    |             |
| Half Baths          | 0  |                |                                 |    |             |
| Extra Fixtures      |    |                |                                 |    |             |
| Total Rooms         | 2  | 2 Rooms        |                                 |    |             |
| Bath Style          |    |                |                                 |    |             |
| Kitchen Style       |    |                |                                 |    |             |
| Occupancy           |    |                |                                 |    |             |
| Usrflid 105         |    |                |                                 |    |             |
| Accessory Apt       |    |                |                                 |    |             |
| Foundation Alt      | 03 | Conc. Slab     |                                 |    |             |
| Rms Prts            |    |                |                                 |    |             |
| Bath Split          | 10 | 1 Full-0 Half  |                                 |    |             |

| CONDO DATA  |      |             |          |
|-------------|------|-------------|----------|
| Parcel Id   |      | C           | Ownr 0.0 |
|             |      | B           | S        |
| Adjust Type | Code | Description | Factor%  |
| Condo Flr   |      |             |          |
| Condo Unit  |      |             |          |

| COST / MARKET VALUATION  |         |
|--------------------------|---------|
| Building Value New       | 223,768 |
| Year Built               | 2000    |
| Effective Year Built     | 2006    |
| Depreciation Code        | A       |
| Remodel Rating           |         |
| Year Remodeled           |         |
| Depreciation %           | 10      |
| Functional Obsol         | 0       |
| External Obsol           | 0       |
| Trend Factor             | 1       |
| Condition                |         |
| Condition %              |         |
| Percent Good             | 90      |
| RCNLD                    | 201,400 |
| Dep % Ovr                |         |
| Dep Ovr Comment          |         |
| Misc Imp Ovr             |         |
| Misc Imp Ovr Comment     |         |
| Cost to Cure Ovr         |         |
| Cost to Cure Ovr Comment |         |

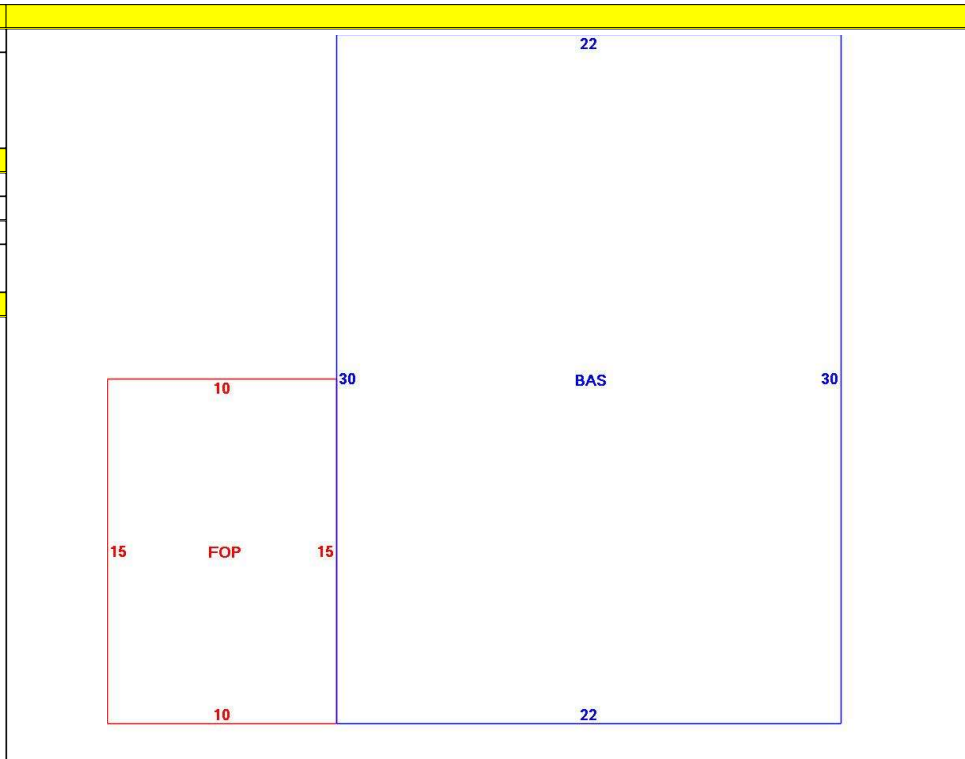

| OB - OUTBUILDING & YARD ITEMS(L) / XF - BUILDING EXTRA FEATURES(B) |               |     |       |            |        |          |      |       |            |             |
|--------------------------------------------------------------------|---------------|-----|-------|------------|--------|----------|------|-------|------------|-------------|
| Code                                                               | Description   | L/B | Units | Unit Price | Yr Blt | Cond. Cd | % Gd | Grade | Grade Adj. | Appr. Value |
| FOP                                                                | Open Porch-ro | B   | 150   | 55.00      | 2008   |          | 90   |       | 0.00       | 6,600       |

| BUILDING SUB-AREA SUMMARY SECTION |             |             |            |          |           |                |
|-----------------------------------|-------------|-------------|------------|----------|-----------|----------------|
| Code                              | Description | Living Area | Floor Area | Eff Area | Unit Cost | Undeprec Value |
| BAS                               | First Floor | 660         | 660        | 660      | 339.04    | 223,768        |
| FOP                               | Open Porch  | 0           | 150        | 0        | 0.00      | 0              |
| Ttl Gross Liv / Lease Area        |             | 660         | 810        | 660      |           | 223,768        |

