

| CURRENT OWNER | | TOPO | UTILITIES | STRT / ROAD | LOCATION | CURRENT ASSESSMENT | | | |
|--------------------------|--|---------|----------------|------------------|----------|---------------------------|------|----------|----------|
| CARNEY, JOHN J & DELIA M | | 1 Level | 6 Septic | 1 Paved | | Description | Code | Assessed | Assessed |
| 165 MISTIC DR | | | 4 Gas | | | RESIDNTL | 1010 | 756,900 | 756,900 |
| MARSTONS MIL MA 02648 | | | 2 Public Water | | | RES LAND | 1010 | 247,700 | 247,700 |
| SUPPLEMENTAL DATA | | | | | | | | | |
| Alt Prcl ID | | | | Plan Ref. 203/53 | | | | | |
| Split Zonin | | | | Land Ct# | | | | | |
| BID Parcel | | | | #SR | | | | | |
| ResExpt Q YES: | | | | Life Estate | | | | | |
| #DL 1 LOT 48 | | | | PP STATU | | | | | |
| #DL 2 | | | | Assoc Pid# | | | | | |
| GIS ID F_952825_2703923 | | | | | | Total 1,004,600 1,004,600 | | | |

801
 FY2024
 BARNSTABLE, MA

VISION

| RECORD OF OWNERSHIP | | BK-VOL/PAGE | SALE DATE | Q/U | V/I | SALE PRIC | VC | PREVIOUS ASSESSMENTS (HISTORY) | | | | | | | | |
|---------------------------------|--|-------------|------------|-----|-----|-----------|----|--------------------------------|------|----------|------|------|----------|--|-------|---------|
| CARNEY, JOHN J & DELIA M | | 10600 0114 | 02-06-1997 | U | I | 1 | 1A | Year | Code | Assessed | Year | Code | Assessed | | | |
| CARNEY, JOHN J | | 7240 0256 | 07-15-1990 | U | V | 65,000 | L | 2023 | 1010 | 652,000 | 2022 | 1010 | 531,900 | | | |
| BOGLE, JAMES F TR | | 4740 0065 | 10-15-1985 | U | V | 2,250,000 | N | | 1010 | 225,200 | | 1010 | 155,100 | | | |
| INDIAN LAKES REALTY CORPORATION | | 2474 0159 | 03-01-1977 | U | | 0 | | | | | | 1010 | 3,000 | | | |
| Total | | | | | | | | | | 877,200 | | | 687,000 | | Total | 644,900 |

| EXEMPTIONS | | | OTHER ASSESSMENTS | | | | | |
|------------|------|-----------------------|-------------------|------|-------------|--------|--------|----------|
| Year | Code | Description | Amount | Code | Description | Number | Amount | Comm Int |
| 2024 | 5C | RESIDENTIAL EXEMPTION | | | | | | |
| Total | | | 0.00 | | | | | |

This signature acknowledges a visit by a Data Collector or Assessor

| ASSESSING NEIGHBORHOOD | | | | APPRAISED VALUE SUMMARY | | | |
|------------------------|-----------|---|---------|--|--|--|--|
| Nbhd | Nbhd Name | B | Tracing | Batch | | | |
| 0108 | | | | MARSTM | | | |
| NOTES | | | | | | | |
| | | | | Appraised Bldg. Value (Card) 692,700 | | | |
| | | | | Appraised Xf (B) Value (Bldg) 61,200 | | | |
| | | | | Appraised Ob (B) Value (Bldg) 3,000 | | | |
| | | | | Appraised Land Value (Bldg) 247,700 | | | |
| | | | | Special Land Value 0 | | | |
| | | | | Total Appraised Parcel Value 1,004,600 | | | |
| | | | | Valuation Method C | | | |
| | | | | Total Appraised Parcel Value 1,004,600 | | | |

| BUILDING PERMIT RECORD | | | | | | | | | VISIT / CHANGE HISTORY | | | | | |
|------------------------|------------|------|-------------|---------|------------|--------|------------|----------------------|------------------------|----|------|----|----|----------------------------|
| Permit Id | Issue Date | Type | Description | Amount | Insp Date | % Comp | Date Comp | Comments | Date | Id | Type | Is | Cd | Purpost/Result |
| 201204591 | 07-30-2012 | NR | New Roof | 11,000 | 06-30-2013 | 100 | 06-30-2013 | REROOF STRIPPING OLD | 09-27-2023 | JO | 03 | | 16 | In Office Review |
| 20066 | 12-19-1996 | DW | Dwelling | 182,160 | 08-18-1998 | 100 | 12-31-1998 | DWELLING | 05-12-2020 | LS | | | FR | Field Review |
| | | | | | | | | | 08-18-2016 | KM | 02 | | 03 | Cycl Insp Comp |
| | | | | | | | | | 01-30-2006 | PT | 02 | | 01 | Meas/Est |
| | | | | | | | | | 06-25-1999 | RW | 01 | | 00 | Meas/Listed-Interior Acces |
| | | | | | | | | | 06-16-1999 | DD | 01 | | 00 | Meas/Listed-Interior Acces |

| LAND LINE VALUATION SECTION | | | | | | | | | | | | | | | | |
|-----------------------------|----------|----------------|------|----|------------|------------|------------------------|---------|------------|-------|-------|-----------|------------------|--------------------|------------|------------|
| B | Use Code | Description | Zone | LA | Land Units | Unit Price | Size Adj | AC Disc | Site Index | Cond. | Nbhd. | Nbhd. Adj | Notes | Location Adjustmen | Adj Unit P | Land Value |
| 1 | 1010 | Single Fam M-0 | RF | 3 | 1.000 AC | 176,344.00 | 1.00000 | 1.0000 | 5 | 1.00 | 0107 | 1.400 | | 1.0000 | 246,881.6 | 246,900 |
| 1 | 1010 | Single Fam M-0 | RF | 3 | 0.040 AC | 14,250.00 | 1.00000 | 1.0000 | 0 | 1.00 | 0107 | 1.400 | | 1.0000 | 19,950 | 800 |
| Total Card Land Units | | | | | 1.04 | AC | Parcel Total Land Area | | | | | 1.04 | Total Land Value | | | 247,700 |

| CONSTRUCTION DETAIL | | | CONSTRUCTION DETAIL (CONTINUED) | | |
|---------------------|----|----------------|---------------------------------|----|-------------|
| Element | Cd | Description | Element | Cd | Description |
| Style | 03 | Colonial | | | |
| Model | 01 | Residential | | | |
| Grade: | C+ | Average Plus | | | |
| Stories | 2 | 2 Stories | | | |
| Exterior Wall 1 | 14 | Wood Shingle | | | |
| Exterior Wall 2 | 11 | Clapboard | | | |
| RooF Structure | 03 | Gable/Hip | | | |
| RooF Cover | 03 | Asph/F Gls/Cmp | | | |
| Interior Wall 1 | 05 | Drywall | | | |
| Interior Wall 2 | | | | | |
| Interior Floor 1 | 14 | Carpet | | | |
| Interior Floor 2 | 12 | Hardwood | | | |
| Heat Fuel | 03 | Gas | | | |
| Heat Type | 04 | Hot Air | | | |
| AC Type | 01 | None | | | |
| Bedrooms | 04 | 4 Bedrooms | | | |
| Full Baths | 2 | | | | |
| Half Baths | 1 | | | | |
| Extra Fixtures | | | | | |
| Total Rooms | 9 | 9 Rooms | | | |
| Bath Style | | | | | |
| Kitchen Style | | | | | |
| Occupancy | | | | | |
| Usrflid 105 | | | | | |
| Accessory Apt | | | | | |
| Foundation Alt | 01 | Poured Conc. | | | |
| Rms Prts | | | | | |
| Bath Split | 21 | 2 Full-1 Half | | | |

| CONDO DATA | | | | | |
|-------------|------|-------------|---------|------|-----|
| Parcel Id | | C | | Owne | 0.0 |
| Adjust Type | Code | Description | Factor% | | |
| Condo Flr | | | | | |
| Condo Unit | | | | | |
| | | | | | |
| | | | | | |
| | | | | | |
| | | | | | |
| | | | | | |

| COST / MARKET VALUATION | | |
|--------------------------|--|---------|
| Building Value New | | 787,143 |
| Year Built | | 1997 |
| Effective Year Built | | 2004 |
| Depreciation Code | | A |
| Remodel Rating | | |
| Year Remodeled | | |
| Depreciation % | | 12 |
| Functional Obsol | | 0 |
| External Obsol | | 0 |
| Trend Factor | | 1 |
| Condition | | |
| Condition % | | |
| Percent Good | | 88 |
| RCNLD | | 692,700 |
| Dep % Ovr | | |
| Dep Ovr Comment | | |
| Misc Imp Ovr | | |
| Misc Imp Ovr Comment | | |
| Cost to Cure Ovr | | |
| Cost to Cure Ovr Comment | | |

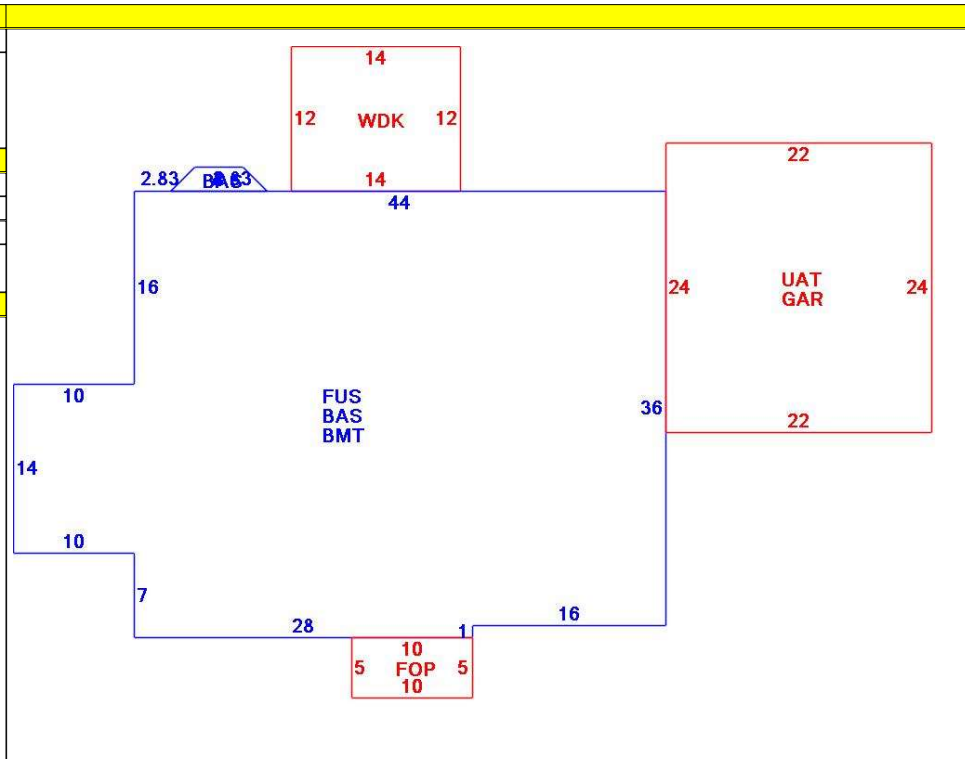

| OB - OUTBUILDING & YARD ITEMS(L) / XF - BUILDING EXTRA FEATURES(B) | | | | | | | | | | |
|--|-----------------|-----|-------|------------|--------|----------|------|-------|------------|-------------|
| Code | Description | L/B | Units | Unit Price | Yr Blt | Cond. Cd | % Gd | Grade | Grade Adj. | Appr. Value |
| FPL3 | Fireplace 2 sto | B | 1 | 7000.00 | 2006 | | 88 | | 0.00 | 6,200 |
| WDC | Wood Decking | L | 168 | 20.00 | 2004 | | 70 | | 0.00 | 3,000 |
| FOP | Open Porch-ro | B | 50 | 55.00 | 2006 | | 88 | | 0.00 | 2,900 |
| GAR | Attached Gara | B | 528 | 40.00 | 2006 | | 88 | | 0.00 | 16,900 |
| BMT | Basement-Unfi | B | 1,752 | 26.01 | 2006 | | 88 | | 0.00 | 35,200 |

| BUILDING SUB-AREA SUMMARY SECTION | | | | | | |
|-----------------------------------|-------------------|-------------|------------|----------|-----------|----------------|
| Code | Description | Living Area | Floor Area | Eff Area | Unit Cost | Undeprec Value |
| BAS | First Floor | 1,764 | 1,764 | 1,764 | 220.55 | 389,050 |
| BMT | Basement Area | 0 | 1,752 | 0 | 0.00 | 0 |
| FOP | Open Porch | 0 | 50 | 0 | 0.00 | 0 |
| FUS | Upper Story | 1,752 | 1,752 | 1,752 | 220.55 | 386,404 |
| GAR | Attached Garage | 0 | 528 | 0 | 0.00 | 0 |
| UAT | Attic, Unfinished | 0 | 528 | 53 | 22.14 | 11,689 |
| WDK | Wood Deck | 0 | 168 | 0 | 0.00 | 0 |
| Ttl Gross Liv / Lease Area | | 3,516 | 6,542 | 3,569 | | 787,143 |

