

CURRENT OWNER		TOPO	UTILITIES	STRT / ROAD	LOCATION	CURRENT ASSESSMENT				801 FY2024 BARNSTABLE, MA VISION	
SEKERAK, STEPHEN P & ANN C 52 MIDDLE POND PATH MARSTONS MIL MA 02648		1 Level	2 Public Water	1 Paved		Description	Code	Assessed	Assessed		
			4 Gas			RESIDNTL	1010	487,300	487,300		
			6 Septic			RES LAND	1010	247,500	247,500		
SUPPLEMENTAL DATA						Total				734,800	734,800
Alt Prcl ID Split Zonin BID Parcel ResExpt Q YES: #DL 1 LOT 21 #DL 2 GIS ID F_952321_2705442				Plan Ref. 203/53 Land Ct# #SR Life Estate PP STATU Assoc Pid#							

RECORD OF OWNERSHIP		BK-VOL/PAGE	SALE DATE	Q/U	V/I	SALE PRIC	VC	PREVIOUS ASSESSMENTS (HISTORY)								
SEKERAK, STEPHEN P & ANN C		25365 0086	04-06-2011	Q	I	425,000	00	Year	Code	Assessed	Year	Code	Assessed	Year	Code	Assessed
CLARK, NORMAN W & LYDIA R TRS		7892 0114	02-15-1992	U	I	1	A	2023	1010	420,900	2022	1010	364,800	2021	1010	300,300
CLARK, NORMAN W & LYDIA R		3859 0289	03-15-1983	Q	V	30,000	U		1010	225,000		1010	155,000		1010	157,400
															1010	1,700
								Total		645,900	Total		519,800	Total		459,400

EXEMPTIONS				OTHER ASSESSMENTS				This signature acknowledges a visit by a Data Collector or Assessor										
Year	Code	Description	Amount	Code	Description	Number	Amount	Comm Int										
2013	5C	RESIDENTIAL EXEMPTION	0.00															
Total			0.00															

ASSESSING NEIGHBORHOOD				APPRAISED VALUE SUMMARY								
Nbhd	Nbhd Name	B		Tracing	Batch							
0107					MARSTM							
NOTES								Appraised Bldg. Value (Card)				417,800
								Appraised Xf (B) Value (Bldg)				67,800
								Appraised Ob (B) Value (Bldg)				1,700
								Appraised Land Value (Bldg)				247,500
								Special Land Value				0
								Total Appraised Parcel Value				734,800
								Valuation Method				C
								Total Appraised Parcel Value				734,800

BUILDING PERMIT RECORD								VISIT / CHANGE HISTORY							
Permit Id	Issue Date	Type	Description	Amount	Insp Date	% Comp	Date Comp	Comments	Date	Id	Type	Is	Cd	Purpost/Result	
EXPR-21-1	10-14-2021	835	Sid/Wind/Roof/	14,500		100		Remove existng asphalt roof ,	05-12-2020	LS			FR	Field Review	
20-1400	06-03-2020	835	Sid/Wind/Roof/	8,500		100		Replace wood paneling in cour	07-11-2018	SR	02		03	Cycl Insp Comp	
17-1343	05-03-2017	835	Sid/Wind/Roof/	3,915		100		Replacement Windows (1) uv	06-19-2012	GC	03		16	In Office Review	
B28651	11-01-1985	DW	Dwelling	125,000	01-15-1987	100	12-31-1987	MM 1 STOR	05-16-2012	TP	03		16	In Office Review	
									03-02-2012	NF	02		20	Sale Review	
									01-06-2012	DR	22		22	Change of Address	
									02-01-2006	PT	02		01	Meas/Est	

LAND LINE VALUATION SECTION																	
B	Use Code	Description	Zone	LA	Land Units	Unit Price	Size Adj	AC Disc	Site Index	Cond.	Nbhd.	Nbhd. Adj	Notes	Location Adjustmen	Adj Unit P	Land Value	
1	1010	Single Fam M-0	RF	3	1.000 AC	176,344.00	1.00000	1.0000	5	1.00	0107	1.400		1.0000	246,881.6	246,900	
1	1010	Single Fam M-0	RF	3	0.030 AC	14,250.00	1.00000	1.0000	0	1.00	0107	1.400		1.0000	19,950	600	
Total Card Land Units					1.03 AC	Parcel Total Land Area					1.03	Total Land Value					247,500

CONSTRUCTION DETAIL			CONSTRUCTION DETAIL (CONTINUED)		
Element	Cd	Description	Element	Cd	Description
Style	01	Ranch			
Model	01	Residential			
Grade:	C+	Average Plus			
Stories	1	1 Story			
Exterior Wall 1	14	Wood Shingle			
Exterior Wall 2	06	Vertical Sidin			
Roof Structure	03	Gable/Hip			
Roof Cover	03	Asph/F Gls/Cmp			
Interior Wall 1	05	Drywall			
Interior Wall 2					
Interior Floor 1	12	Hardwood			
Interior Floor 2					
Heat Fuel	03	Gas			
Heat Type	04	Hot Air			
AC Type	03	Central			
Bedrooms	03	3 Bedrooms			
Full Baths	1				
Half Baths	1				
Extra Fixtures					
Total Rooms	6	6 Rooms			
Bath Style					
Kitchen Style					
Occupancy					
Usrflid 105					
Accessory Apt					
Foundation Alt	01	Poured Conc.			
Rms Prts					
Bath Split	11	1 Full-1 Half			

CONDO DATA			
Parcel Id	C	Owne	0.0
Adjust Type	Code	Description	Factor%
Condo Flr			
Condo Unit			

COST / MARKET VALUATION	
Building Value New	497,416
Year Built	1985
Effective Year Built	1998
Depreciation Code	A
Remodel Rating	
Year Remodeled	
Depreciation %	16
Functional Obsol	0
External Obsol	0
Trend Factor	1
Condition	
Condition %	
Percent Good	84
RCNLD	417,800
Dep % Ovr	
Dep Ovr Comment	
Misc Imp Ovr	
Misc Imp Ovr Comment	
Cost to Cure Ovr	
Cost to Cure Ovr Comment	

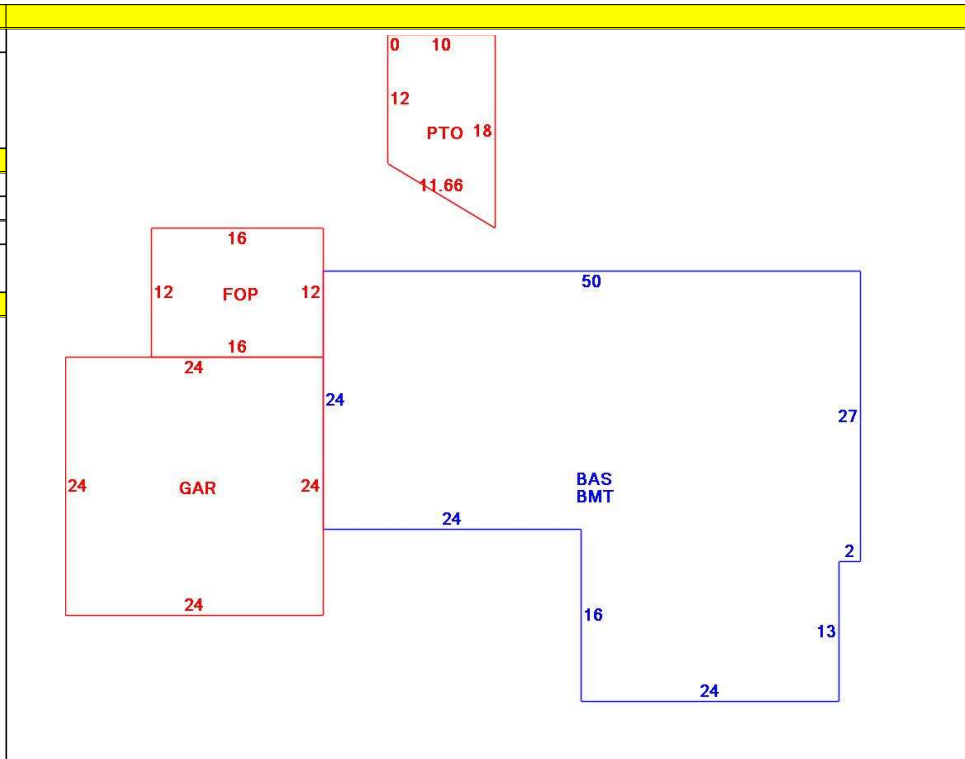

OB - OUTBUILDING & YARD ITEMS(L) / XF - BUILDING EXTRA FEATURES(B)										
Code	Description	L/B	Units	Unit Price	Yr Blt	Cond. Cd	% Gd	Grade	Grade Adj.	Appr. Value
FPL1	Fireplace 1 sto	B	1	5000.00	2000		84		0.00	4,200
BRR	Bsmt Rec Rm-	B	1,200	8.05	2000		84		0.00	8,100
FOP	Open Porch-ro	B	192	55.00	2000		84		0.00	7,300
GAR	Attached Gara	B	576	40.00	2000		84		0.00	17,200
BMT	Basement-Unfi	B	1,590	26.01	2000		84		0.00	31,000
PAT2	Patio-Good	L	150	9.94	2017		98		0.00	1,700

BUILDING SUB-AREA SUMMARY SECTION						
Code	Description	Living Area	Floor Area	Eff Area	Unit Cost	Undeprec Value
BAS	First Floor	1,590	1,590	1,590	312.84	497,416
BMT	Basement Area	0	1,590	0	0.00	0
FOP	Open Porch	0	192	0	0.00	0
GAR	Attached Garage	0	576	0	0.00	0
PTO	Patio	0	150	0	0.00	0
Ttl Gross Liv / Lease Area		1,590	4,098	1,590		497,416

