

| CURRENT OWNER | | TOPO | UTILITIES | STRT / ROAD | LOCATION | CURRENT ASSESSMENT | | | |
|--|--|----------------|-----------|-------------|--|-------------------------------------|----------------------|----------------------------------|----------------------------------|
| HOLLY BAY FAMILY LP 2118 E DESERT GARDEN DR TUCSON AZ 85718-7846 | | 3 Below Street | 4 Gas | | 1 Lake/Pond Fro | Description RESIDNTL RES LAND | Code 1010 1010 | Assessed 1,365,100 616,900 | Assessed 1,365,100 616,900 |
| | | | 5 Well | 1 Paved | 1 Excel View | | | | |
| | | | 6 Septic | | | | | | |
| SUPPLEMENTAL DATA | | | | | | | | | |
| Alt Prcl ID Split Zonin BID Parcel ResExpt Q #DL 1 #DL 2 GIS ID F_954242_2709743 | | | | | Plan Ref. Land Ct# #SR Life Estate PP STATU A:Active Assoc Pid# | | | | |
| | | | | | | Total | 1,982,000 | 1,982,000 | |

801
 FY2024
 BARNSTABLE, MA
VISION

| RECORD OF OWNERSHIP | | BK-VOL/PAGE | SALE DATE | Q/U | V/I | SALE PRIC | VC | PREVIOUS ASSESSMENTS (HISTORY) | | | | | | | | |
|-------------------------------|-------|-------------|------------|------|------------|-----------|------|--------------------------------|-------|-----------|----------|-----------|-----------|------|------|---------|
| Year | Code | Assessed | Year | Code | Assessed V | Year | Code | Assessed | Year | Code | Assessed | | | | | |
| HOLLY BAY FAMILY LP | 26972 | 0035 | 12-21-2012 | U | I | 10 | 1F | | | | | | | | | |
| LENK, EDWARD C JR TR | 26554 | 0270 | 08-02-2012 | U | I | 10 | 1F | 2023 | 1010 | 1,078,200 | 2022 | 1010 | 1,009,900 | 2021 | 1010 | 820,000 |
| LENK, EDWARD C JR | 9429 | 0350 | 11-15-1994 | U | I | 0 | 1 | | 1010 | 735,600 | | 1010 | 434,100 | | 1010 | 463,000 |
| LENK, MARILYN D & EDWARD C JR | 8287 | 0316 | 11-15-1992 | U | I | 100 | 1A | | | | | | | | 1010 | 66,800 |
| LENK, MARILYN D | 3044 | 0213 | 01-14-1980 | U | | 0 | 1A | | | | | | | | | |
| Total | | | | | | | | 1,813,800 | Total | 1,444,000 | Total | 1,349,800 | | | | |

| EXEMPTIONS | | | | OTHER ASSESSMENTS | | | |
|------------|------|-------------|--------|-------------------|-------------|--------|--------|
| Year | Code | Description | Amount | Code | Description | Number | Amount |
| | | | 0.00 | | | | |

This signature acknowledges a visit by a Data Collector or Assessor

APPRAISED VALUE SUMMARY

Appraised Bldg. Value (Card) 1,173,800
 Appraised Xf (B) Value (Bldg) 124,500
 Appraised Ob (B) Value (Bldg) 66,800
 Appraised Land Value (Bldg) 616,900
 Special Land Value 0
 Total Appraised Parcel Value 1,982,000
 Valuation Method C
 Total Appraised Parcel Value 1,982,000

| ASSESSING NEIGHBORHOOD | | | |
|------------------------|-----------|---|---------|
| Nbhd | Nbhd Name | B | Tracing |
| 0111 | | | MARSTM |

| NOTES | | | | | | | | | |
|-------|--|--|--|--|--|--|--|--|--|
| | | | | | | | | | |

| BUILDING PERMIT RECORD | | | | | | | | | VISIT / CHANGE HISTORY | | | | | |
|------------------------|------------|------|-------------|---------|------------|--------|------------|---------------------------|------------------------|----|------|----|----|-----------------------|
| Permit Id | Issue Date | Type | Description | Amount | Insp Date | % Comp | Date Comp | Comments | Date | Id | Type | Is | Cd | Purpost/Result |
| 200904689 | 10-14-2009 | WD | Wood Deck | 2,500 | 04-08-2010 | 100 | 06-30-2010 | 23 X 12 WDCK; FIN BTH O/G | 10-25-2022 | BM | 22 | | 22 | Change of Address |
| 200904781 | 10-06-2009 | GN | Generator | 0 | 04-08-2010 | 100 | 06-30-2010 | GENERATOR | 05-12-2020 | LS | | | FR | Field Review |
| 200902446 | 06-02-2009 | RE | Remodel | 5,000 | 04-08-2010 | 100 | 06-30-2010 | ROUGH BTH O GAR | 12-22-2014 | AL | 22 | | 22 | Change of Address |
| 200902445 | 06-02-2009 | RW | Repair Work | 5,000 | 04-08-2010 | 100 | 06-30-2010 | BOATHSE | 02-17-2012 | RB | 03 | | 16 | In Office Review |
| 200802399 | 07-07-2008 | DW | Dwelling | 650,000 | 07-30-2009 | 100 | 06-30-2009 | REBLD 4BDRM | 01-26-2012 | TP | 03 | | 16 | In Office Review |
| 200802398 | 07-07-2008 | DE | Demolish | 12,000 | 07-30-2009 | 100 | 06-30-2009 | EXIST DW | 05-07-2010 | NF | 03 | | 02 | Bldg Permit Completed |
| | | | | | | | | | 04-08-2010 | MK | 02 | | 52 | New Construction |

| LAND LINE VALUATION SECTION | | | | | | | | | | | | | | | | |
|-----------------------------|----------|----------------|------|----|------------|---------------|------------------------|---------|------------|-------|-------|-----------|------------------|--------------------|------------|------------|
| B | Use Code | Description | Zone | LA | Land Units | Unit Price | Size Adj | AC Disc | Site Index | Cond. | Nbhd. | Nbhd. Adj | Notes | Location Adjustmen | Adj Unit P | Land Value |
| 1 | 1010 | Single Fam M-0 | RF | 3 | 1.000 | AC 176,344.00 | 1.00000 | 1.0000 | 5 | 1.00 | 0111 | 3.050 | MIDDLE POND | | 1.0000 | 537,849.2 |
| 1 | 1010 | Single Fam M-0 | RF | 3 | 1.820 | AC 14,250.00 | 1.00000 | 1.0000 | 0 | 1.00 | 0111 | 3.050 | | | 1.0000 | 79,100 |
| Total Card Land Units | | | | | 2.82 | AC | Parcel Total Land Area | | | | | 2.82 | Total Land Value | | | 616,900 |

| CONSTRUCTION DETAIL | | | CONSTRUCTION DETAIL (CONTINUED) | | |
|---------------------|------|----------------|---------------------------------|------|---------------------|
| Element | Cd | Description | Element | Cd | Description |
| Style | 07 | Modern/Contemp | | | |
| Model | 01 | Residential | | | |
| Grade: | B+ | Custom Plus | | | |
| Stories | 1.75 | 1 3/4 Stories | | | |
| Exterior Wall 1 | 14 | Wood Shingle | | | |
| Exterior Wall 2 | | | | | |
| RooF Structure | 03 | Gable/Hip | | | |
| RooF Cover | 03 | Asph/F Gls/Cmp | | | |
| Interior Wall 1 | 05 | Drywall | | | |
| Interior Wall 2 | | | | | |
| Interior Floor 1 | 14 | Carpet | | | |
| Interior Floor 2 | 22 | Wide Pine | | | |
| Heat Fuel | 03 | Gas | | | |
| Heat Type | 04 | Hot Air | | | |
| AC Type | 03 | Central | | | |
| Bedrooms | 04 | 4 Bedrooms | | | |
| Full Baths | 4 | | | | |
| Half Baths | 1 | | | | |
| Extra Fixtures | | | | | |
| Total Rooms | 9 | | | | |
| Bath Style | | | | | |
| Kitchen Style | | | | | |
| Occupancy | | | | | |
| Usrflid 105 | | | | | |
| Accessory Apt | | | | | |
| Foundation Alt | 01 | Poured Conc. | | | |
| Rms Prts | | | | | |
| Bath Split | 41 | 4 Full-1 Half | | | |
| | | | CONDO DATA | | |
| | | | Parcel Id | C | Ownr 0.0 |
| | | | Adjust Type | Code | Description Factor% |
| | | | Condo Flr | | |
| | | | Condo Unit | | |
| | | | COST / MARKET VALUATION | | |
| | | | Building Value New | | 1,262,149 |
| | | | Year Built | | 2008 |
| | | | Effective Year Built | | 2010 |
| | | | Depreciation Code | | A |
| | | | Remodel Rating | | |
| | | | Year Remodeled | | |
| | | | Depreciation % | | 7 |
| | | | Functional Obsol | | 0 |
| | | | External Obsol | | 0 |
| | | | Trend Factor | | 1 |
| | | | Condition | | |
| | | | Condition % | | |
| | | | Percent Good | | 93 |
| | | | RCNLD | | 1,173,800 |
| | | | Dep % Ovr | | |
| | | | Dep Ovr Comment | | |
| | | | Misc Imp Ovr | | |
| | | | Misc Imp Ovr Comment | | |
| | | | Cost to Cure Ovr | | |
| | | | Cost to Cure Ovr Comment | | |

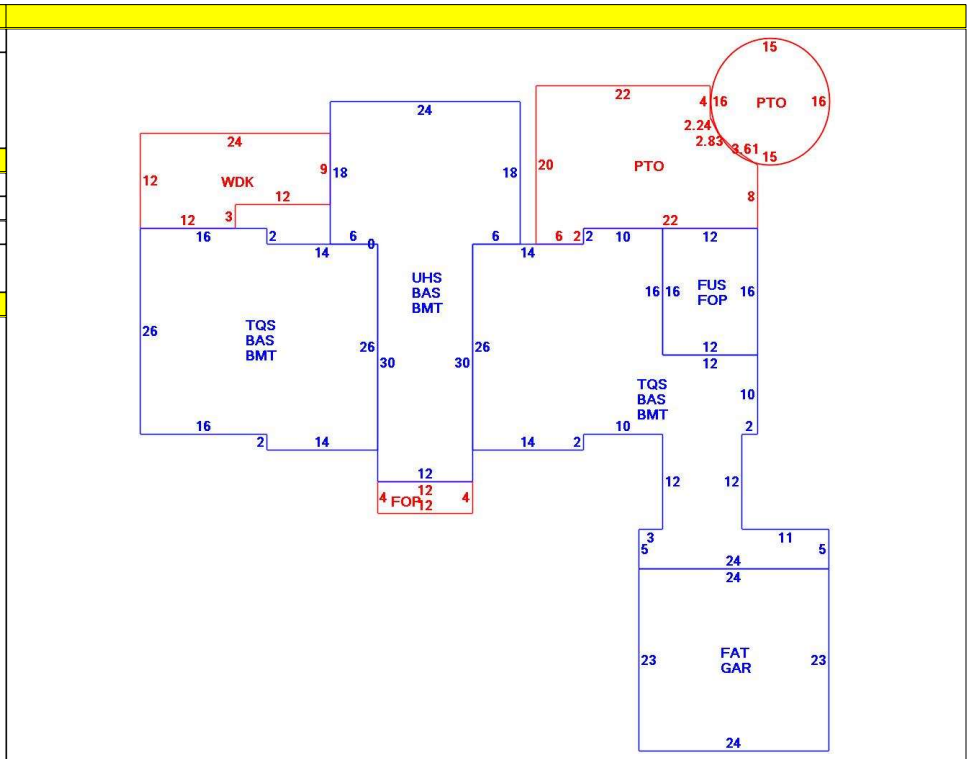

| OB - OUTBUILDING & YARD ITEMS(L) / XF - BUILDING EXTRA FEATURES(B) | | | | | | | | | | |
|--|-----------------|-----|-------|------------|--------|----------|------|-------|------------|-------------|
| Code | Description | L/B | Units | Unit Price | Yr Blt | Cond. Cd | % Gd | Grade | Grade Adj. | Appr. Value |
| FPLG | Gas Fireplace- | B | 2 | 2500.00 | 2012 | | 93 | | 0.00 | 4,700 |
| BFA | Bsmt Fin-Avg | B | 2,556 | 17.36 | 2012 | | 93 | | 0.00 | 41,300 |
| GEN | Emergency Ge | L | 1 | 5550.00 | 2009 | | 80 | | 0.00 | 4,400 |
| STRS | Stairs to Water | L | 33 | 122.52 | 2009 | | 80 | B | 1.32 | 4,300 |
| WDC | Wood Deck w/ | L | 252 | 18.00 | 2010 | | 82 | | 0.00 | 4,000 |
| PATF | Flagstone Pav | L | 658 | 30.00 | 2010 | | 91 | | 0.00 | 17,000 |
| FOP | Open Porch-ro | B | 240 | 55.00 | 2012 | | 93 | | 0.00 | 9,400 |
| GAR | Attached Gara | B | 552 | 40.00 | 2012 | | 93 | | 0.00 | 18,500 |
| BMT | Basement-Unfi | B | 2,556 | 26.01 | 2012 | | 93 | | 0.00 | 50,600 |
| GSQT | Guest Quarter | L | 483 | 122.81 | 1970 | | 51 | C | 1.00 | 27,400 |

| BUILDING SUB-AREA SUMMARY SECTION | | | | | | |
|-----------------------------------|------------------------|-------------|------------|----------|-----------|----------------|
| Code | Description | Living Area | Floor Area | Eff Area | Unit Cost | Undeprec Value |
| BAS | First Floor | 2,556 | 2,556 | 2,556 | 299.37 | 765,193 |
| BMT | Basement Area | 0 | 2,556 | 0 | 0.00 | 0 |
| FAT | Attic, Finished | 83 | 552 | 83 | 45.01 | 24,848 |
| FOP | Open Porch | 0 | 240 | 0 | 0.00 | 0 |
| FUS | Upper Story | 192 | 192 | 192 | 299.37 | 57,479 |
| GAR | Attached Garage | 0 | 552 | 0 | 0.00 | 0 |
| PTO | Patio | 0 | 658 | 0 | 0.00 | 0 |
| TQS | Three Quarter Story | 1,147 | 1,764 | 1,147 | 194.66 | 343,379 |
| UHS | Half Story, Unfinished | 0 | 792 | 238 | 89.96 | 71,250 |
| WDK | Wood Deck | 0 | 252 | 0 | 0.00 | 0 |
| Ttl Gross Liv / Lease Area | | 3,978 | 10,114 | 4,216 | | 1,262,149 |



| CURRENT OWNER | | TOPO | UTILITIES | STRT / ROAD | LOCATION | CURRENT ASSESSMENT | | | |
|--|--|----------------|-----------|-------------|--|-------------------------------------|----------------------|----------------------------------|----------------------------------|
| HOLLY BAY FAMILY LP 2118 E DESERT GARDEN DR TUCSON AZ 85718-7846 | | 3 Below Street | 4 Gas | | 1 Lake/Pond Fro | Description RESIDNTL RES LAND | Code 1010 1010 | Assessed 1,365,100 616,900 | Assessed 1,365,100 616,900 |
| | | | 5 Well | 1 Paved | 1 Excel View | | | | |
| | | | 6 Septic | | | | | | |
| SUPPLEMENTAL DATA | | | | | | | | | |
| Alt Prcl ID Split Zonin BID Parcel ResExpt Q #DL 1 #DL 2 GIS ID F_954242_2709743 | | | | | Plan Ref. Land Ct# #SR Life Estate PP STATU A:Active Assoc Pid# | | | | |
| | | | | | | Total | 1,982,000 | 1,982,000 | |

801
 FY2024
 BARNSTABLE, MA
VISION

| RECORD OF OWNERSHIP | | BK-VOL/PAGE | SALE DATE | Q/U | V/I | SALE PRIC | VC | PREVIOUS ASSESSMENTS (HISTORY) | | | | | |
|---------------------|------|-------------|-----------|------|------------|-----------|------|--------------------------------|--|--|--|--|--|
| Year | Code | Assessed | Year | Code | Assessed V | Year | Code | Assessed | | | | | |
| 2023 | 1010 | 1,078,200 | 2022 | 1010 | 1,009,900 | 2021 | 1010 | 820,000 | | | | | |
| | 1010 | 735,600 | | 1010 | 434,100 | | 1010 | 463,000 | | | | | |
| | | | | | | | 1010 | 66,800 | | | | | |
| Total | | 1,813,800 | Total | | 1,444,000 | Total | | 1,349,800 | | | | | |

| EXEMPTIONS | | | | OTHER ASSESSMENTS | | | |
|------------|------|-------------|--------|-------------------|-------------|--------|--------|
| Year | Code | Description | Amount | Code | Description | Number | Amount |
| Total | | | | | | | |

This signature acknowledges a visit by a Data Collector or Assessor

| ASSESSING NEIGHBORHOOD | | | |
|------------------------|-----------|---|---------|
| Nbhd | Nbhd Name | B | Tracing |
| 0111 | | | MARSTM |

| NOTES | | | |
|-------|--|--|--|
| | | | |

| APPRAISED VALUE SUMMARY | |
|-------------------------------|-----------|
| Appraised Bldg. Value (Card) | 1,173,800 |
| Appraised Xf (B) Value (Bldg) | 124,500 |
| Appraised Ob (B) Value (Bldg) | 66,800 |
| Appraised Land Value (Bldg) | 616,900 |
| Special Land Value | 0 |
| Total Appraised Parcel Value | 1,982,000 |
| Valuation Method | C |
| Total Appraised Parcel Value | 1,982,000 |

| BUILDING PERMIT RECORD | | | | | | | VISIT / CHANGE HISTORY | | | | | | | |
|------------------------|------------|------|-------------|--------|-----------|--------|------------------------|----------|------|----|------|----|----|----------------|
| Permit Id | Issue Date | Type | Description | Amount | Insp Date | % Comp | Date Comp | Comments | Date | Id | Type | Is | Cd | Purpost/Result |
| | | | | | | | | | | | | | | |

| LAND LINE VALUATION SECTION | | | | | | | | | | | | | | | | |
|-----------------------------|----------|-------------|------|----|------------------------|------------|----------|---------|------------|------------------|-------|-----------|-------|--------------------|------------|------------|
| B | Use Code | Description | Zone | LA | Land Units | Unit Price | Size Adj | AC Disc | Site Index | Cond. | Nbhd. | Nbhd. Adj | Notes | Location Adjustmen | Adj Unit P | Land Value |
| | | | | | | | | | | | | | | | | |
| Total Card Land Units | | | | | Parcel Total Land Area | | | | | Total Land Value | | | | | | |

