

CURRENT OWNER		TOPO	UTILITIES	STRT / ROAD	LOCATION	CURRENT ASSESSMENT				
MEAGHER, SEAN P  1410 S E 17TH STREET  FORT LAUDERD FL 33316	3	Below Street	4	Gas	1	Lake/Pond Fro	Description	Code	Assessed	Assessed
	5	Well	1	Paved	1	Excel View	RESIDNTL	1010	506,900	506,900
	6	Septic					RES LAND	1010	604,300	604,300
<b>SUPPLEMENTAL DATA</b>										
Alt Prcl ID Split Zonin BID Parcel ResExpt Q #DL 1 #DL 2 GIS ID F_953952_2709639			Plan Ref. 128/25 Land Ct# #SR Life Estate PP STATU Assoc Pid#			Total		1,111,200	1,111,200	

801  
 FY2024  
 BARNSTABLE, MA

**VISION**

RECORD OF OWNERSHIP		BK-VOL/PAGE	SALE DATE	Q/U	V/I	SALE PRIC	VC	PREVIOUS ASSESSMENTS (HISTORY)					
MEAGHER, SEAN P	31057	0170	01-31-2018	Q	I	754,250	00	Year	Code	Assessed	Year	Code	Assessed
GODE, A JAY & PAMELA J	2743	0314	07-07-1978	U		0		2023	1010	444,600	2022	1010	386,900
									1010	719,300		1010	421,700
											2021	1010	280,000
												1010	449,800
												1010	42,200
Total								1,163,900	Total	808,600	Total	772,000	

EXEMPTIONS			OTHER ASSESSMENTS					
Year	Code	Description	Amount	Code	Description	Number	Amount	Comm Int
			0.00					

This signature acknowledges a visit by a Data Collector or Assessor

ASSESSING NEIGHBORHOOD			
Nbhd	Nbhd Name	B	Tracing
0111			MARSTM

NOTES	

APPRAISED VALUE SUMMARY	
Appraised Bldg. Value (Card)	424,100
Appraised Xf (B) Value (Bldg)	40,600
Appraised Ob (B) Value (Bldg)	42,200
Appraised Land Value (Bldg)	604,300
Special Land Value	0
Total Appraised Parcel Value	1,111,200
Valuation Method	C
Total Appraised Parcel Value	1,111,200

BUILDING PERMIT RECORD								VISIT / CHANGE HISTORY						
Permit Id	Issue Date	Type	Description	Amount	Insp Date	% Comp	Date Comp	Comments	Date	Id	Type	Is	Cd	Purpost/Result
18-2035	07-06-2018	835	Sid/Wind/Roof/	40,000		100		siding/(18) Windows	05-12-2020	LS			FR	Field Review
18-1007	04-05-2018	834	Sheet Metal	15,000		0		2 New Systems One In Attic a	07-17-2018	SR	02		02	Bldg Permit Completed
B33206	09-01-1989	AD	Addition	3,500	01-15-1991	100	12-31-1991	MM ADD'N	03-13-2006	JK	22		22	Change of Address
B32189	08-01-1988	AD	Addition	50,000	01-15-1990	100	12-31-1990	MM GARAGE	03-02-2006	PT	02		01	Meas/Est
									09-15-1999	MF			10	Desk Aerial Review
									07-03-1999	FS	02		01	Meas/Est

LAND LINE VALUATION SECTION																
B	Use Code	Description	Zone	LA	Land Units	Unit Price	Size Adj	AC Disc	Site Index	Cond.	Nbhd.	Nbhd. Adj	Notes	Location Adjustmen	Adj Unit P	Land Value
1	1010	Single Fam M-0	RF	3	1.000	AC 176,344.00	1.00000	1.0000	5	1.00	0111	3.050	MIDDLE POND	1.0000	537,849.2	537,800
1	1010	Single Fam M-0	RF	3	1.530	AC 14,250.00	1.00000	1.0000	0	1.00	0111	3.050		1.0000	43,462.5	66,500
Total Card Land Units					2.53	AC	Parcel Total Land Area					2.53	Total Land Value			604,300

CONSTRUCTION DETAIL			CONSTRUCTION DETAIL (CONTINUED)		
Element	Cd	Description	Element	Cd	Description
Style	01	Ranch			
Model	01	Residential			
Grade:	C+	Average Plus			
Stories	1	1 Story			
Exterior Wall 1	14	Wood Shingle			
Exterior Wall 2					
RooF Structure	03	Gable/Hip			
RooF Cover	03	Asph/F Gls/Cmp			
Interior Wall 1	05	Drywall			
Interior Wall 2					
Interior Floor 1	12	Hardwood			
Interior Floor 2					
Heat Fuel	02	Oil			
Heat Type	05	Hot Water			
AC Type	03	Central			
Bedrooms	02	2 Bedrooms			
Full Baths	2				
Half Baths	1				
Extra Fixtures					
Total Rooms	7	7 Rooms			
Bath Style					
Kitchen Style					
Occupancy					
Usrflid 105					
Accessory Apt					
Foundation Alt	08	Mixed			
Rms Prts					
Bath Split	21	2 Full-1 Half			

CONDO DATA			
Parcel Id		C	Ownr 0.0
		B	S
Adjust Type	Code	Description	Factor%
Condo Flr			
Condo Unit			

COST / MARKET VALUATION	
Building Value New	550,802
Year Built	1969
Effective Year Built	1990
Depreciation Code	A
Remodel Rating	
Year Remodeled	
Depreciation %	23
Functional Obsol	0
External Obsol	0
Trend Factor	1
Condition	
Condition %	
Percent Good	77
RCNLD	424,100
Dep % Ovr	
Dep Ovr Comment	
Misc Imp Ovr	
Misc Imp Ovr Comment	
Cost to Cure Ovr	
Cost to Cure Ovr Comment	

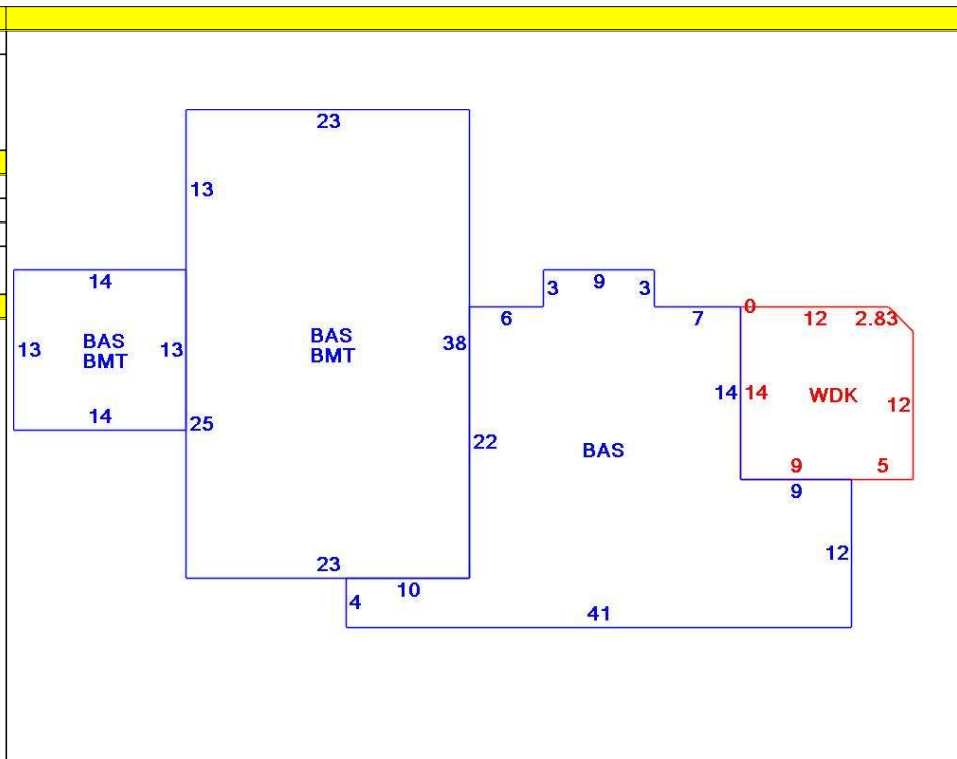

OB - OUTBUILDING & YARD ITEMS(L) / XF - BUILDING EXTRA FEATURES(B)										
Code	Description	L/B	Units	Unit Price	Yr Blt	Cond. Cd	% Gd	Grade	Grade Adj.	Appr. Value
FPL1	Fireplace 1 sto	B	2	5000.00	1992		77		0.00	7,700
BRN4	Barn w/Bmt&Lt	L	864	65.10	1980		61	C+	1.10	37,700
BFA	Bsmt Fin-Avg	B	874	17.36	1992		77		0.00	11,700
WDC	Wood Decking	L	194	20.00	1995		52		0.00	2,400
BMT	Basement-Unfi	B	1,056	26.01	1992		77		0.00	21,200
BRN1	Barn - 1 Story	L	292	29.38	1980		22	C+	1.10	2,100

BUILDING SUB-AREA SUMMARY SECTION						
Code	Description	Living Area	Floor Area	Eff Area	Unit Cost	Undeprec Value
BAS	First Floor	1,803	1,803	1,803	305.49	550,802
BMT	Basement Area	0	1,056	0	0.00	0
WDK	Wood Deck	0	194	0	0.00	0
Ttl Gross Liv / Lease Area		1,803	3,053	1,803		550,802

