

CURRENT OWNER		TOPO	UTILITIES	STRT / ROAD	LOCATION	CURRENT ASSESSMENT			
BARBO, COREY A & BRIELLE B 51 PETER BLOSSOM LANE WEST BARNSTA MA 02668		1 Level	4 Gas	1 Paved		Description	Code	Assessed	Assessed
			5 Well			RESIDNTL	1010	567,600	567,600
			6 Septic			RES LAND	1010	176,300	176,300
SUPPLEMENTAL DATA						Total 743,900 743,900			
Alt Prcl ID		Split Zonin		Plan Ref.					
BID Parcel		ResExpt Q NO APP:		Land Ct# 40599-B					
#DL 1 LOT 9		#DL 2		#SR					
GIS ID F_954934_2721920				Life Estate					
				PP STATU					
				Assoc Pid#					

801
 FY2024
 BARNSTABLE, MA

VISION

RECORD OF OWNERSHIP		BK-VOL/PAGE	SALE DATE	Q/U	V/I	SALE PRIC	VC	PREVIOUS ASSESSMENTS (HISTORY)						
BARBO, COREY A & BRIELLE B		C229647	0	04-13-2022	Q	I	690,000	00	Year	Code	Assessed	Year	Code	Assessed
SPELLACY, PAULA TR		C202368	0	12-24-2013	U	I	1	1A	2023	1010	494,000	2022	1010	426,600
SPELLACY, ADRIENNE Z		#D10634	0	05-10-2007	U	I	0	1		1010	160,300		1010	118,800
SPELLACY, WILLIAM & ADRIENNE Z		C136725	0	03-27-1995	Q	I	45,000	00					1010	6,100
SNOWDEN, LAURIE P TR		C135475	0	11-03-1994	U	V	103,000	1A	Total 654,300 Total 545,400 Total 469,500					

EXEMPTIONS			OTHER ASSESSMENTS					
Year	Code	Description	Amount	Code	Description	Number	Amount	Comm Int
2024	N5C	NO RESIDENTIAL EXEMPTION	0.00					
Total			0.00					

This signature acknowledges a visit by a Data Collector or Assessor

ASSESSING NEIGHBORHOOD				
Nbhd	Nbhd Name	B	Tracing	Batch
0105				WBARN5

APPRAISED VALUE SUMMARY			
Appraised Bldg. Value (Card)			496,300
Appraised Xf (B) Value (Bldg)			65,200
Appraised Ob (B) Value (Bldg)			6,100
Appraised Land Value (Bldg)			176,300
Special Land Value			0
Total Appraised Parcel Value			743,900
Valuation Method			C
Total Appraised Parcel Value			743,900

NOTES							

BUILDING PERMIT RECORD								VISIT / CHANGE HISTORY						
Permit Id	Issue Date	Type	Description	Amount	Insp Date	% Comp	Date Comp	Comments	Date	Id	Type	Is	Cd	Purpost/Result
78384	07-22-2004	RA	Remodel-Additi	58,000	05-31-2005	100	01-01-2005	DWELLING	05-19-2020	DM			FR	Field Review
19543	11-22-1996	DW	Dwelling	140,000	06-04-1998	100	12-31-1998		05-24-2017	KM	02		03	Cycl Insp Comp
									03-08-2006	PT	01		00	Meas/Listed-Interior Acces
									05-31-2005	MF	02		02	Bldg Permit Completed
									03-01-2000	PT	01		00	Meas/Listed-Interior Acces

LAND LINE VALUATION SECTION																	
B	Use Code	Description	Zone	LA	Land Units	Unit Price	Size Adj	AC Disc	Site Index	Cond.	Nbhd.	Nbhd. Adj	Notes	Location Adjustmen	Adj Unit P	Land Value	
1	1010	Single Fam M-0	RF	5	1.000	AC	176,344.00	1.00000	1.0000	5	1.00	0105	1.000		1.0000	176,344	176,300
Total Card Land Units					1.00	AC	Parcel Total Land Area					1.00	Total Land Value				176,300

CONSTRUCTION DETAIL			CONSTRUCTION DETAIL (CONTINUED)		
Element	Cd	Description	Element	Cd	Description
Style	01	Ranch			
Model	01	Residential			
Grade:	C	Average			
Stories	1	1 Story			
Exterior Wall 1	11	Clapboard			
Exterior Wall 2	14	Wood Shingle			
RooF Structure	03	Gable/Hip			
RooF Cover	03	Asph/F Gls/Cmp			
Interior Wall 1	03	Plastered			
Interior Wall 2					
Interior Floor 1	14	Carpet			
Interior Floor 2	12	Hardwood			
Heat Fuel	03	Gas			
Heat Type	05	Hot Water			
AC Type	03	Central			
Bedrooms	04	4 Bedrooms			
Full Baths	2				
Half Baths	0				
Extra Fixtures					
Total Rooms	8	8 Rooms			
Bath Style					
Kitchen Style					
Occupancy					
UsrflD 105					
Accessory Apt					
Foundation Alt	01	Poured Conc.			
Rms Prts					
Bath Split	20	2 Full-0 Half			
			CONDO DATA		
Parcel Id		C	Owne		0.0
Adjust Type		Code	Description		Factor%
Condo Flr			Condo Unit		
			COST / MARKET VALUATION		
Building Value New				563,969	
Year Built				1997	
Effective Year Built				2004	
Depreciation Code				A	
Remodel Rating					
Year Remodeled					
Depreciation %				12	
Functional Obsol				0	
External Obsol				0	
Trend Factor				1	
Condition					
Condition %					
Percent Good				88	
RCNLD				496,300	
Dep % Ovr					
Dep Ovr Comment					
Misc Imp Ovr					
Misc Imp Ovr Comment					
Cost to Cure Ovr					
Cost to Cure Ovr Comment					

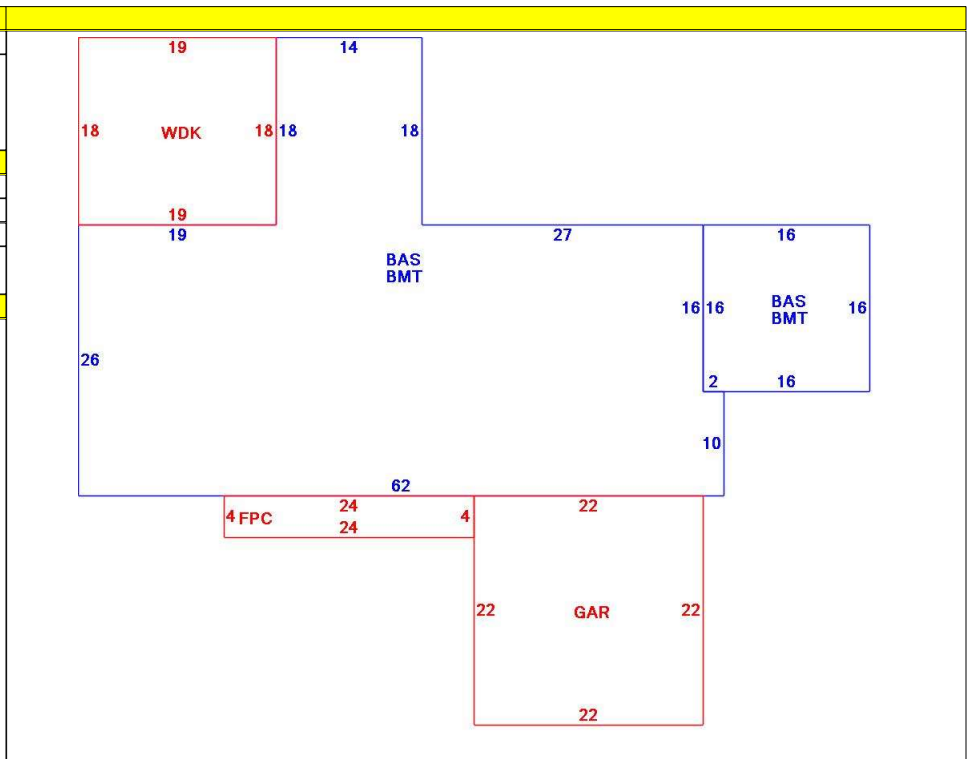

OB - OUTBUILDING & YARD ITEMS(L) / XF - BUILDING EXTRA FEATURES(B)										
Code	Description	L/B	Units	Unit Price	Yr Blt	Cond. Cd	% Gd	Grade	Grade Adj.	Appr. Value
FPL1	Fireplace 1 sto	B	1	5000.00	2006		88		0.00	4,400
WDC	Wood Decking	L	342	20.00	2004		70		0.00	4,700
FOPC	Open Prch-roo	B	96	55.00	2006		88		0.00	4,000
GAR	Attached Gara	B	484	40.00	2006		88		0.00	16,000
BMT	Basement-Unfi	B	2,088	26.01	2006		88		0.00	40,800
SHED	Shed	L	80	18.00	2017		96		0.00	1,400

BUILDING SUB-AREA SUMMARY SECTION						
Code	Description	Living Area	Floor Area	Eff Area	Unit Cost	Undeprec Value
BAS	First Floor	2,088	2,088	2,088	270.10	563,969
BMT	Basement Area	0	2,088	0	0.00	0
FPC	Open Porch Conc. Floor	0	96	0	0.00	0
GAR	Attached Garage	0	484	0	0.00	0
WDC	Wood Deck	0	342	0	0.00	0
Ttl Gross Liv / Lease Area		2,088	5,098	2,088		563,969

