

| CURRENT OWNER | | | | TOPO | UTILITIES | STRT / ROAD | LOCATION | CURRENT ASSESSMENT | | | | |
|-------------------------|--|--|--|------|-----------|------------------|----------|--------------------|------|-----------|-----------|---------------------------------|
| TILTON, SUMNER B JR | | | | | | | | Description | Code | Assessed | Assessed | 801 FY2024 BARNSTABLE, MA |
| 370 MAIN STREET | | | | | | | | RESIDNTL | 1010 | 491,400 | 491,400 | |
| WORCESTER MA 01608 | | | | | | | | RES LAND | 1010 | 1,144,100 | 1,144,100 | |
| SUPPLEMENTAL DATA | | | | | | | | | | | | VISION |
| Alt Prcl ID | | | | | | Plan Ref. 519/80 | | | | | | |
| Split Zonin | | | | | | Land Ct# | | | | | | |
| BID Parcel | | | | | | #SR | | | | | | |
| ResExpt Q | | | | | | Life Estate | | | | | | |
| #DL 1 LOT 1B | | | | | | PP STATU | | | | | | |
| #DL 2 | | | | | | Assoc Pid# | | | | | | |
| GIS ID F_955297_2690271 | | | | | | | | Total | | 1,635,500 | 1,635,500 | |

| RECORD OF OWNERSHIP | | | | BK-VOL/PAGE | SALE DATE | Q/U | V/I | SALE PRIC | VC | PREVIOUS ASSESSMENTS (HISTORY) | | | | | | | | | |
|------------------------------|--|--|--|-------------|-----------|------------|-----|-----------|-----------|--------------------------------|-----------|-------|-----------|-------|-----------|----------|------|------|----------|
| TILTON, SUMNER B JR | | | | 10267 | 0209 | 06-24-1996 | U | I | 1 | 1A | Year | Code | Assessed | Year | Code | Assessed | Year | Code | Assessed |
| TILTON, SUMNER B JR & MARTHA | | | | 9397 | 0028 | 10-15-1994 | U | I | 1,100,000 | N | 2023 | 1010 | 420,500 | 2022 | 1010 | 354,800 | 2021 | 1010 | 265,400 |
| KANE, KENNETH A | | | | 9397 | 0027 | 10-06-1994 | U | | 1 | A | | 1010 | 1,041,500 | | 1010 | 848,300 | | 1010 | 908,800 |
| KANE, KENNETH A & GENEVIEVE | | | | 0956 | 0218 | 10-17-1956 | U | | 0 | | | | | | | | | 1010 | 35,400 |
| Total | | | | | | | | | | | 1,462,000 | Total | 1,203,100 | Total | 1,209,600 | | | | |

| EXEMPTIONS | | | | OTHER ASSESSMENTS | | | | This signature acknowledges a visit by a Data Collector or Assessor | | | | | | | | | | | | |
|------------|------|-------------|--------|-------------------|-------------|--------|--------|---|--|--|--|--|--|--|--|--|--|--|--|--|
| Year | Code | Description | Amount | Code | Description | Number | Amount | Comm Int | | | | | | | | | | | | |
| | | | | | | | | | | | | | | | | | | | | |
| Total | | | 0.00 | | | | | | | | | | | | | | | | | |

| ASSESSING NEIGHBORHOOD | | | | APPRAISED VALUE SUMMARY | | | | | | | |
|------------------------|-----------|---|---------|-------------------------|--|--|--|--|--|--|--|
| Nbhd | Nbhd Name | B | Tracing | Batch | | | | | | | |
| 0115 | | | OSTVIL | | | | | | | | |

| NOTES | | | | | | | | | | | | APPRAISED VALUE SUMMARY | | | | | | |
|-------|--|--|--|--|--|--|--|--|--|--|--|-------------------------------|--|--|--|--|--|-----------|
| | | | | | | | | | | | | Appraised Bldg. Value (Card) | | | | | | 438,100 |
| | | | | | | | | | | | | Appraised Xf (B) Value (Bldg) | | | | | | 17,900 |
| | | | | | | | | | | | | Appraised Ob (B) Value (Bldg) | | | | | | 35,400 |
| | | | | | | | | | | | | Appraised Land Value (Bldg) | | | | | | 1,144,100 |
| | | | | | | | | | | | | Special Land Value | | | | | | 0 |
| | | | | | | | | | | | | Total Appraised Parcel Value | | | | | | 1,635,500 |
| | | | | | | | | | | | | Valuation Method | | | | | | C |
| | | | | | | | | | | | | Total Appraised Parcel Value | | | | | | 1,635,500 |

| BUILDING PERMIT RECORD | | | | | | | | | VISIT / CHANGE HISTORY | | | | | | | | |
|------------------------|------------|------|--------------|---------|------------|--------|------------|------------------|------------------------|----|------|----|----|----------------------------|--|--|--|
| Permit Id | Issue Date | Type | Description | Amount | Insp Date | % Comp | Date Comp | Comments | Date | Id | Type | Is | Cd | Purpost/Result | | | |
| 32661 | 08-11-1998 | OB | Out Building | 10,000 | 01-15-1999 | 100 | 12-31-1999 | TENNIS SHED 8X22 | 06-05-2020 | WD | | | FR | Field Review | | | |
| 11645 | 11-01-1995 | DW | Dwelling | 211,000 | 09-16-1996 | 100 | 01-01-1997 | OS 1 STOR | 04-27-2018 | MS | 03 | | 16 | In Office Review | | | |
| 11409 | 11-01-1995 | DE | Demolish | 1,700 | 01-15-1996 | 100 | 12-31-1996 | OS GARAGE | 10-25-2016 | KM | 02 | | 03 | Cycl Insp Comp | | | |
| B37330 | 12-01-1994 | DE | Demolish | 0 | 01-15-1996 | 100 | 12-31-1996 | OS DWELL. | 04-06-2011 | MK | 02 | | 52 | New Construction | | | |
| | | | | | | | | | 03-20-2006 | PT | 02 | | 01 | Meas/Est | | | |
| | | | | | | | | | 09-16-1997 | LK | 01 | | 00 | Meas/Listed-Interior Acces | | | |

| LAND LINE VALUATION SECTION | | | | | | | | | | | | | | | | |
|-----------------------------|----------|----------------|------|----|------------|---------------|------------------------|---------|------------|-------|-------|-----------|------------------|--------------------|------------|------------|
| B | Use Code | Description | Zone | LA | Land Units | Unit Price | Size Adj | AC Disc | Site Index | Cond. | Nbhd. | Nbhd. Adj | Notes | Location Adjustmen | Adj Unit P | Land Value |
| 1 | 1010 | Single Fam M-0 | RF-1 | 3 | 1.000 | AC 176,344.00 | 1.00000 | 1.0000 | 5 | 1.00 | 0115 | 6.400 | | 1.0000 | 1,128,601 | 1,128,600 |
| 1 | 1010 | Single Fam M-0 | RF-1 | 3 | 0.170 | AC 14,250.00 | 1.00000 | 1.0000 | 0 | 1.00 | 0115 | 6.400 | | 1.0000 | 91,200 | 15,500 |
| Total Card Land Units | | | | | 1.17 | AC | Parcel Total Land Area | | | | | 1.17 | Total Land Value | | | 1,144,100 |

| CONSTRUCTION DETAIL | | | CONSTRUCTION DETAIL (CONTINUED) | | |
|---------------------|----|----------------|---------------------------------|------|-------------|
| Element | Cd | Description | Element | Cd | Description |
| Style | 06 | Conventional | | | |
| Model | 01 | Residential | | | |
| Grade: | C+ | Average Plus | | | |
| Stories | 1 | 1 Story | | | |
| Exterior Wall 1 | 14 | Wood Shingle | | | |
| Exterior Wall 2 | | | | | |
| RooF Structure | 03 | Gable/Hip | | | |
| RooF Cover | 10 | Wood Shingle | | | |
| Interior Wall 1 | 03 | Plastered | | | |
| Interior Wall 2 | | | | | |
| Interior Floor 1 | 14 | Carpet | | | |
| Interior Floor 2 | 12 | Hardwood | | | |
| Heat Fuel | 03 | Gas | | | |
| Heat Type | 03 | Hot Air-No Duc | | | |
| AC Type | 03 | Central | | | |
| Bedrooms | 02 | 2 Bedrooms | | | |
| Full Baths | 2 | | | | |
| Half Baths | 0 | | | | |
| Extra Fixtures | | | | | |
| Total Rooms | 6 | 6 Rooms | | | |
| Bath Style | | | | | |
| Kitchen Style | | | | | |
| Occupancy | | | | | |
| UsrflD 105 | | | | | |
| Accessory Apt | | | | | |
| Foundation Alt | 01 | Poured Conc. | | | |
| Rms Prts | | | | | |
| Bath Split | 20 | 2 Full-0 Half | | | |
| | | | CONDO DATA | | |
| | | | Parcel Id | C | Ownr 0.0 |
| | | | | B | S |
| | | | Adjust Type | Code | Description |
| | | | Condo Flr | | Factor% |
| | | | Condo Unit | | |
| | | | COST / MARKET VALUATION | | |
| | | | Building Value New | | 497,795 |
| | | | Year Built | | 1996 |
| | | | Effective Year Built | | 2004 |
| | | | Depreciation Code | | A |
| | | | Remodel Rating | | |
| | | | Year Remodeled | | |
| | | | Depreciation % | | 12 |
| | | | Functional Obsol | | 0 |
| | | | External Obsol | | 0 |
| | | | Trend Factor | | 1 |
| | | | Condition | | |
| | | | Condition % | | |
| | | | Percent Good | | 88 |
| | | | RCNLD | | 438,100 |
| | | | Dep % Ovr | | |
| | | | Dep Ovr Comment | | |
| | | | Misc Imp Ovr | | |
| | | | Misc Imp Ovr Comment | | |
| | | | Cost to Cure Ovr | | |
| | | | Cost to Cure Ovr Comment | | |

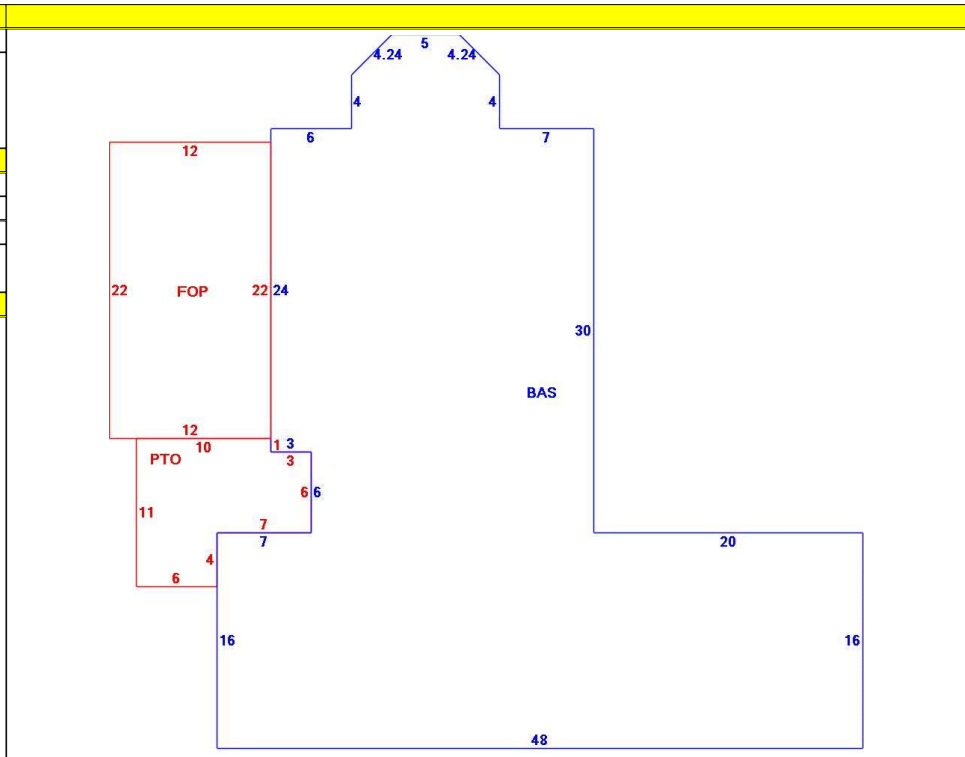

| OB - OUTBUILDING & YARD ITEMS(L) / XF - BUILDING EXTRA FEATURES(B) | | | | | | | | | | |
|--|-----------------|-----|-------|------------|--------|----------|------|-------|------------|-------------|
| Code | Description | L/B | Units | Unit Price | Yr Blt | Cond. Cd | % Gd | Grade | Grade Adj. | Appr. Value |
| TEN | Tennis Court | L | 7,200 | 6.84 | 1996 | | 54 | 00 | 1.00 | 26,600 |
| FPL1 | Fireplace 1 sto | B | 1 | 5000.00 | 2006 | | 88 | | 0.00 | 4,400 |
| SHD3 | Shed-High Qu | L | 176 | 25.00 | 1998 | | 58 | | 0.00 | 2,600 |
| FOP | Open Porch-ro | B | 264 | 55.00 | 2006 | | 88 | | 0.00 | 9,500 |
| FOPC | Open Prch-roo | B | 96 | 55.00 | 2006 | | 88 | | 0.00 | 4,000 |
| SHD2 | Shed w/Elec | L | 96 | 26.00 | 2016 | | 94 | | 0.00 | 2,300 |
| PATF | Flagstone Pav | L | 112 | 30.00 | 2016 | | 97 | | 0.00 | 3,900 |

| BUILDING SUB-AREA SUMMARY SECTION | | | | | | |
|-----------------------------------|-------------|-------------|------------|----------|-----------|----------------|
| Code | Description | Living Area | Floor Area | Eff Area | Unit Cost | Undeprec Value |
| BAS | First Floor | 1,538 | 1,538 | 1,538 | 323.66 | 497,795 |
| FOP | Open Porch | 0 | 264 | 0 | 0.00 | 0 |
| PTO | Patio | 0 | 112 | 0 | 0.00 | 0 |
| Ttl Gross Liv / Lease Area | | 1,538 | 1,914 | 1,538 | | 497,795 |

