

| CURRENT OWNER | | | TOPO | UTILITIES | STRT / ROAD | LOCATION | CURRENT ASSESSMENT | | | | |
|---|--|--|--|----------------|-------------|-----------------|--------------------|------|-----------|-----------|--|
| STARR, KEVIN P TR ST MARY'S ISLAND TRUST 130 COMMONWEALTH AVE BOSTON MA 02116 | | | 1 Level | 2 Public Water | 1 Paved | 7 Waterfront | Description | Code | Assessed | Assessed | 801 FY2024 BARNSTABLE, MA VISION |
| | | | | 4 Gas | | 1 Excel View | RESIDNTL | 1090 | 3,612,000 | 3,612,000 | |
| | | | | 6 Septic | | 9 Rear Location | RES LAND | 1090 | 5,741,700 | 5,741,700 | |
| SUPPLEMENTAL DATA | | | | | | | Total | | | | |
| Alt Prcl ID Split Zonin BID Parcel ResExpt Q #DL 1 6970-A & 3 #DL 2 GIS ID F_956750_2692875 | | | Plan Ref. Land Ct# 5725-P #SR Life Estate PP STATU Assoc Pid# | | | | | | | | |

| RECORD OF OWNERSHIP | | | BK-VOL/PAGE | SALE DATE | Q/U | V/I | SALE PRIC | VC | PREVIOUS ASSESSMENTS (HISTORY) | | | | | | | | | |
|---|--|--|-------------|-----------|------------|-----|-----------|------------|--------------------------------|-----------|-------|-----------|-------|-----------|------------|------|------|-----------|
| STARR, KEVIN P TR SULLIVAN, MARGARET W TR SULLIVAN, JAMES F TR SULLIVAN, JAMES F SULLIVAN, JAMES F TR | | | C215452 | 0 | 02-21-2018 | U | I | 11,250,000 | 1V | Year | Code | Assessed | Year | Code | Assessed V | Year | Code | Assessed |
| | | | NO15P33 | 0 | 12-10-2015 | U | I | 0 | 1A | 2023 | 1090 | 3,069,300 | 2022 | 1090 | 2,540,600 | 2021 | 1090 | 1,982,900 |
| | | | C193777 | 0 | 03-09-2011 | U | I | 1 | 1F | | 1090 | 5,292,900 | | 1090 | 5,159,900 | | 1090 | 4,865,400 |
| | | | C148271 | 0 | 04-29-1998 | U | I | 1 | 1A | | | | | | | | 1090 | 127,000 |
| | | | C128866 | 0 | 12-29-1992 | U | I | 3,900,000 | N | | | | | | | | | |
| Total | | | | | | | | | | 8,362,200 | Total | 7,700,500 | Total | 6,975,300 | | | | |

| EXEMPTIONS | | | | OTHER ASSESSMENTS | | | |
|------------|------|-------------|--------|-------------------|-------------|--------|--------|
| Year | Code | Description | Amount | Code | Description | Number | Amount |
| Total | | | 0.00 | | | | |

| ASSESSING NEIGHBORHOOD | | | |
|------------------------|-----------|---|---------|
| Nbhd | Nbhd Name | B | Tracing |
| WF14 | | | OSTVIL |

| NOTES | | | |
|---|--|--|-----------|
| This signature acknowledges a visit by a Data Collector or Assessor | | | |
| APPRAISED VALUE SUMMARY | | | |
| Appraised Bldg. Value (Card) | | | 3,354,600 |
| Appraised Xf (B) Value (Bldg) | | | 130,400 |
| Appraised Ob (B) Value (Bldg) | | | 127,000 |
| Appraised Land Value (Bldg) | | | 5,741,700 |
| Special Land Value | | | 0 |
| Total Appraised Parcel Value | | | 9,353,700 |
| Valuation Method | | | C |
| Total Appraised Parcel Value | | | 9,353,700 |

| BUILDING PERMIT RECORD | | | | | | | | | VISIT / CHANGE HISTORY | | | | | |
|------------------------|------------|------|------------------|---------|------------|--------|------------|------------------------------------|------------------------|----|------|----|----|----------------------------|
| Permit Id | Issue Date | Type | Description | Amount | Insp Date | % Comp | Date Comp | Comments | Date | Id | Type | Is | Cd | Purpost/Result |
| 19-4204 | 01-03-2020 | 804 | Addn Alt-Res | 60,000 | 08-06-2020 | 100 | 06-30-2020 | remove windows and doors | 08-06-2020 | SR | 01 | | 02 | Bldg Permit Completed |
| 19-3837 | 12-06-2019 | 880 | Alt-Int work-Res | 300,000 | 08-06-2020 | 100 | 06-30-2020 | Interior Remodel to include: P | 06-05-2020 | WD | | | FR | Field Review |
| 19-518 | 02-21-2019 | 880 | Alt-Int work-Res | 250,000 | 08-06-2020 | 100 | 06-30-2020 | interior repairs to the kitchen, d | 05-05-2019 | SR | 01 | | 13 | CALL BACK |
| 201203915 | 06-27-2012 | NW | New Windows | 3,550 | 06-30-2012 | 100 | 06-30-2012 | REPLC 2 WINDS .30 U VALU | 03-22-2006 | PT | 01 | | 00 | Meas/Listed-Interior Acces |
| B32109 | 07-01-1988 | AD | Addition | 70,000 | 01-15-1989 | 100 | 12-31-1989 | OS ADD'N | 06-06-2001 | PT | 01 | | 00 | Meas/Listed-Interior Acces |
| B30504 | 03-01-1987 | AD | Addition | 350,000 | 01-15-1988 | 100 | 12-31-1988 | OS REMOD' | 01-15-1989 | ML | 01 | | 00 | Meas/Listed-Interior Acces |
| B26230 | 04-01-1984 | AD | Addition | 0 | 03-15-1985 | 100 | 12-31-1985 | OS ADD'N | | | | | | |

| LAND LINE VALUATION SECTION | | | | | | | | | | | | | | | | |
|-----------------------------|----------|-----------------|------|----|------------|---------------|------------------------|---------|------------|-------|-------|-----------|------------------|--------------------|------------|------------|
| B | Use Code | Description | Zone | LA | Land Units | Unit Price | Size Adj | AC Disc | Site Index | Cond. | Nbhd. | Nbhd. Adj | Notes | Location Adjustmen | Adj Unit P | Land Value |
| 1 | 1090 | Multi Hses M-01 | RF-1 | 3 | 1.000 | AC 176,344.00 | 1.00000 | 1.0000 | 5 | 1.00 | WF14 | 28.000 | | 1.0000 | 4,937,632 | 4,937,600 |
| 1 | 1090 | Multi Hses M-01 | RF-1 | 3 | 2.000 | AC 14,250.00 | 1.00000 | 1.0000 | 0 | 1.00 | WF14 | 28.000 | RESIDUAL | 1.0000 | 399,000 | 798,000 |
| Total Card Land Units | | | | | 3.00 | AC | Parcel Total Land Area | | | | | 5.20 | Total Land Value | | | 5,735,600 |

| CURRENT OWNER | | TOPO | UTILITIES | STRT / ROAD | LOCATION | CURRENT ASSESSMENT | | | | 801 FY2024 BARNSTABLE, MA VISION | |
|--|--|-------------|----------------|-----------------|-----------------|--------------------|------|-----------|-----------|--|-----------|
| STARR, KEVIN P TR ST MARY'S ISLAND TRUST 130 COMMONWEALTH AVE BOSTON MA 02116 | | 1 Level | 2 Public Water | 1 Paved | 7 Waterfront | Description | Code | Assessed | Assessed | | |
| | | | 4 Gas | | 1 Excel View | RESIDNTL | 1090 | 3,612,000 | 3,612,000 | | |
| | | | 6 Septic | | 9 Rear Location | RES LAND | 1090 | 5,741,700 | 5,741,700 | | |
| SUPPLEMENTAL DATA | | | | | | Total | | | | 9,353,700 | 9,353,700 |
| Alt Prcl ID | | Split Zonin | | Plan Ref. | | | | | | | |
| BID Parcel | | ResExpt Q | | Land Ct# 5725-P | | | | | | | |
| #DL 1 6970-A & 3 | | #DL 2 | | Life Estate | | | | | | | |
| GIS ID F_956750_2692875 | | Assoc Pid# | | PP STATU | | | | | | | |

| RECORD OF OWNERSHIP | | BK-VOL/PAGE | SALE DATE | Q/U | V/I | SALE PRIC | VC | PREVIOUS ASSESSMENTS (HISTORY) | | | | | | |
|---------------------|------|-------------|-----------|------|-----------|-----------|------|--------------------------------|------|------|----------|------|------|----------|
| Year | Code | Assessed | Year | Code | Assessed | Year | Code | Assessed | Year | Code | Assessed | Year | Code | Assessed |
| 2023 | 1090 | 3,069,300 | 2022 | 1090 | 2,540,600 | 2021 | 1090 | 1,982,900 | | | | | | |
| | 1090 | 5,292,900 | | 1090 | 5,159,900 | | 1090 | 4,865,400 | | | | | | |
| | | | | | | | 1090 | 127,000 | | | | | | |
| Total | | 8,362,200 | Total | | 7,700,500 | Total | | 6,975,300 | | | | | | |

| EXEMPTIONS | | | OTHER ASSESSMENTS | | | | This signature acknowledges a visit by a Data Collector or Assessor | | | | | | | | | | | | |
|------------|------|-------------|-------------------|------|-------------|--------|---|----------|--|--|--|--|--|--|--|--|--|--|--|
| Year | Code | Description | Amount | Code | Description | Number | Amount | Comm Int | | | | | | | | | | | |
| Total | | | 0.00 | | | | | | | | | | | | | | | | |

| ASSESSING NEIGHBORHOOD | | | | | | APPRAISED VALUE SUMMARY | | | | | |
|---|-----------|---|---------|--------|--|-------------------------|--|--|--|--|--|
| Nbhd | Nbhd Name | B | Tracing | Batch | | | | | | | |
| WF14 | | | | OSTVIL | | | | | | | |
| NOTES | | | | | | | | | | | |
| Appraised Bldg. Value (Card) 3,354,600 Appraised Xf (B) Value (Bldg) 130,400 Appraised Ob (B) Value (Bldg) 127,000 Appraised Land Value (Bldg) 5,741,700 Special Land Value 0 Total Appraised Parcel Value 9,353,700 Valuation Method C Total Appraised Parcel Value 9,353,700 | | | | | | | | | | | |

| BUILDING PERMIT RECORD | | | | | | | | | | VISIT / CHANGE HISTORY | | | | | |
|------------------------|------------|------|-------------|--------|-----------|--------|-----------|----------|------|------------------------|------|----|----|----------------|--|
| Permit Id | Issue Date | Type | Description | Amount | Insp Date | % Comp | Date Comp | Comments | Date | Id | Type | Is | Cd | Purpost/Result | |
| | | | | | | | | | | | | | | | |

| LAND LINE VALUATION SECTION | | | | | | | | | | | | | | | | |
|-----------------------------|----------|-----------------|------|----|------------|------------|------------------------|---------|------------|-------|-------|-----------|------------------|--------------------|------------|------------|
| B | Use Code | Description | Zone | LA | Land Units | Unit Price | Size Adj | AC Disc | Site Index | Cond. | Nbhd. | Nbhd. Adj | Notes | Location Adjustmen | Adj Unit P | Land Value |
| 2 | 1090 | Multi Hses M-01 | RF-1 | 3 | 2.200 AC | 2,750.00 | 1.00000 | 1.0000 | 0 | 1.00 | WTLD | 1.000 | WETLAND | 1.0167 | 2,750 | 6,100 |
| Total Card Land Units | | | | | 2.20 | AC | Parcel Total Land Area | | | | | 5.20 | Total Land Value | | | 6,100 |

| CONSTRUCTION DETAIL | | | CONSTRUCTION DETAIL (CONTINUED) | | |
|---------------------|----|----------------|---------------------------------|----|-------------|
| Element | Cd | Description | Element | Cd | Description |
| Style | 06 | Conventional | | | |
| Model | 01 | Residential | | | |
| Grade: | C | Average | | | |
| Stories | 1 | 1 Story | | | |
| Exterior Wall 1 | 17 | Stucco/Masonry | | | |
| Exterior Wall 2 | | | | | |
| RooF Structure | 03 | Gable/Hip | | | |
| RooF Cover | 03 | Asph/F Gls/Cmp | | | |
| Interior Wall 1 | 05 | Drywall | | | |
| Interior Wall 2 | | | | | |
| Interior Floor 1 | 14 | Carpet | | | |
| Interior Floor 2 | | | | | |
| Heat Fuel | 02 | Oil | | | |
| Heat Type | 05 | Hot Water | | | |
| AC Type | 01 | None | | | |
| Bedrooms | 01 | 1 Bedroom | | | |
| Full Baths | 1 | | | | |
| Half Baths | 0 | | | | |
| Extra Fixtures | | | | | |
| Total Rooms | 2 | 2 Rooms | | | |
| Bath Style | | | | | |
| Kitchen Style | | | | | |
| Occupancy | | | | | |
| Usrflid 105 | | | | | |
| Accessory Apt | | | | | |
| Foundation Alt | 03 | Conc. Slab | | | |
| Rms Prts | | | | | |
| Bath Split | 10 | 1 Full-0 Half | | | |

| CONDO DATA | | | | |
|-------------|------|-------------|---------|----------|
| Parcel Id | | C | | Owne 0.0 |
| | | | B | S |
| Adjust Type | Code | Description | Factor% | |
| Condo Flr | | | | |
| Condo Unit | | | | |

| COST / MARKET VALUATION | |
|--------------------------|---------|
| Building Value New | 209,957 |
| Year Built | 1988 |
| Effective Year Built | 2000 |
| Depreciation Code | A |
| Remodel Rating | |
| Year Remodeled | |
| Depreciation % | 15 |
| Functional Obsol | 0 |
| External Obsol | 0 |
| Trend Factor | 1 |
| Condition | |
| Condition % | |
| Percent Good | 85 |
| RCNLD | 178,500 |
| Dep % Ovr | |
| Dep Ovr Comment | |
| Misc Imp Ovr | |
| Misc Imp Ovr Comment | |
| Cost to Cure Ovr | |
| Cost to Cure Ovr Comment | |

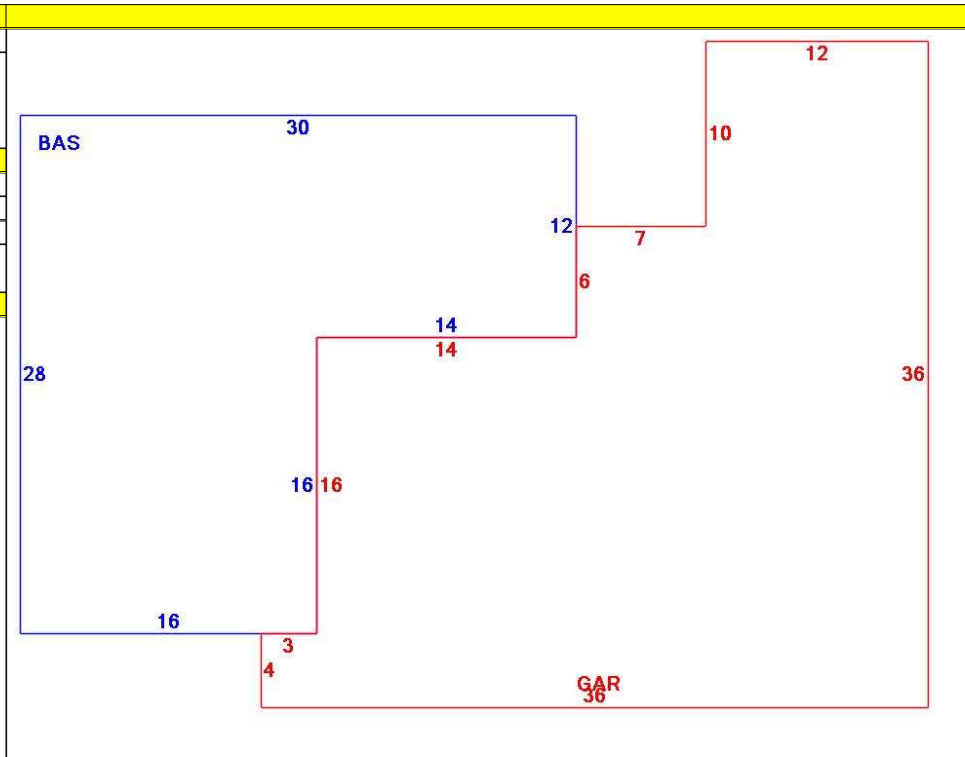

| OB - OUTBUILDING & YARD ITEMS(L) / XF - BUILDING EXTRA FEATURES(B) | | | | | | | | | | |
|--|---------------|-----|-------|------------|--------|----------|------|-------|------------|-------------|
| Code | Description | L/B | Units | Unit Price | Yr Blt | Cond. Cd | % Gd | Grade | Grade Adj. | Appr. Value |
| GAR | Attached Gara | B | 906 | 40.00 | 2002 | | 85 | | 0.00 | 24,400 |
| GEN | Emergency Ge | L | 1 | 5550.00 | 2018 | | 98 | | 0.00 | 5,400 |

| BUILDING SUB-AREA SUMMARY SECTION | | | | | | |
|-----------------------------------|-----------------|-------------|------------|----------|-----------|----------------|
| Code | Description | Living Area | Floor Area | Eff Area | Unit Cost | Undeprec Value |
| BAS | First Floor | 616 | 616 | 616 | 340.84 | 209,957 |
| GAR | Attached Garage | 0 | 906 | 0 | 0.00 | 0 |
| Ttl Gross Liv / Lease Area | | 616 | 1,522 | 616 | | 209,957 |

