

CURRENT OWNER		TOPO	UTILITIES	STRT / ROAD	LOCATION	CURRENT ASSESSMENT				
MCGRATH, BARBARA A TR RKM REALTY TRUST 1760 SOUTH COUNTY ROAD						Description	Code	Assessed	Assessed	801 FY2024 BARNSTABLE, MA
OSTERVILLE MA 02655						RESIDNTL	1010	704,700	704,700	
						RES LAND	1010	203,300	203,300	VISION
SUPPLEMENTAL DATA						Total				
Alt Prcl ID Split Zonin BID Parcel ResExpt Q INFO: #DL 1 LOT 2 #DL 2 GIS ID F_957089_2699780				Plan Ref. 395/95 Land Ct# #SR Life Estate PP STATU Assoc Pid#		908,000				

RECORD OF OWNERSHIP		BK-VOL/PAGE	SALE DATE	Q/U	V/I	SALE PRIC	VC	PREVIOUS ASSESSMENTS (HISTORY)								
MCGRATH, BARBARA A TR		28846 0305	05-05-2015	U	I	1	1F	Year	Code	Assessed	Year	Code	Assessed	Year	Code	Assessed
MCGRATH, BARBARA A		13307 0190	10-19-2000	Q	I	489,456	00	2023	1010	624,300	2022	1010	529,100	2021	1010	446,500
HERITAGE CUSTOM BLDG CO INC		13307 0187	10-19-2000	U	I	100	1B		1010	200,900		1010	143,000		1010	143,000
LEBEL, DOUGLAS W		13113 0021	07-05-2000	U	I	100	1B								1010	4,000
LEBEL, DOUGLAS & SNOWDEN, L P TRS		12455 0239	08-04-1999	U	V	89,900	1B	Total		825,200	Total		672,100	Total		593,500

EXEMPTIONS			OTHER ASSESSMENTS					
Year	Code	Description	Amount	Code	Description	Number	Amount	Comm Int
2024	N5C	NO RESIDENTIAL EXEMPTION						
Total			0.00					

ASSESSING NEIGHBORHOOD			
Nbhd	Nbhd Name	B	Tracing
0106			MARSTM

APPRAISED VALUE SUMMARY	
Appraised Bldg. Value (Card)	634,800
Appraised Xf (B) Value (Bldg)	65,900
Appraised Ob (B) Value (Bldg)	4,000
Appraised Land Value (Bldg)	203,300
Special Land Value	0
Total Appraised Parcel Value	908,000
Valuation Method	C
Total Appraised Parcel Value	908,000

BUILDING PERMIT RECORD								VISIT / CHANGE HISTORY						
Permit Id	Issue Date	Type	Description	Amount	Insp Date	% Comp	Date Comp	Comments	Date	Id	Type	Is	Cd	Purpost/Result
20-2261	08-19-2020	822	Insulation	5,000		100		Add R-38 fiberglass, R-10 rigid	06-02-2020	DM			FR	Field Review
40063	07-29-1999	DW	Dwelling	190,000	04-04-2000	100	01-01-2001		08-14-2019	SR	02		03	Cycl Insp Comp
									01-30-2015	JR	03		03	Cycl Insp Comp
									04-25-2006	PT	02		01	Meas/Est
									01-25-2001	MF	01		00	Meas/Listed-Interior Acces
									11-22-2000	JG			03	Cycl Insp Comp
									04-04-2000	MF	02		05	Measur/New UC Under C

LAND LINE VALUATION SECTION																	
B	Use Code	Description	Zone	LA	Land Units	Unit Price	Size Adj	AC Disc	Site Index	Cond.	Nbhd.	Nbhd. Adj	Notes	Location Adjustmen	Adj Unit P	Land Value	
1	1010	Single Fam M-0	RF	3	1.000 AC	176,344.00	1.00000	1.0000	5	1.00	0106	1.150		1.0000	202,795.6	202,800	
1	1010	Single Fam M-0	RF	3	0.030 AC	14,250.00	1.00000	1.0000	0	1.00	0106	1.150		1.0000	16,387.5	500	
Total Card Land Units					1.03 AC	Parcel Total Land Area					1.03	Total Land Value					203,300

CONSTRUCTION DETAIL			CONSTRUCTION DETAIL (CONTINUED)		
Element	Cd	Description	Element	Cd	Description
Style	04	Cape Cod			
Model	01	Residential			
Grade:	C+	Average Plus			
Stories	1.75	1 3/4 Stories			
Exterior Wall 1	11	Clapboard			
Exterior Wall 2	14	Wood Shingle			
RooF Structure	03	Gable/Hip			
RooF Cover	03	Asph/F Gls/Cmp			
Interior Wall 1	05	Drywall			
Interior Wall 2					
Interior Floor 1	12	Hardwood			
Interior Floor 2					
Heat Fuel	03	Gas			
Heat Type	04	Hot Air			
AC Type	03	Central			
Bedrooms	03	3 Bedrooms			
Full Baths	2				
Half Baths	1				
Extra Fixtures					
Total Rooms	7	7 Rooms			
Bath Style					
Kitchen Style					
Occupancy					
Usrflid 105					
Accessory Apt					
Foundation Alt	01	Poured Conc.			
Rms Prts					
Bath Split	21	2 Full-1 Half			

CONDO DATA				
Parcel Id		C	Owne	0.0
Adjust Type	Code	Description	Factor%	
Condo Flr	Condo Unit			

COST / MARKET VALUATION	
Building Value New	705,280
Year Built	2000
Effective Year Built	2006
Depreciation Code	A
Remodel Rating	
Year Remodeled	
Depreciation %	10
Functional Obsol	0
External Obsol	0
Trend Factor	1
Condition	
Condition %	
Percent Good	90
RCNLD	634,800
Dep % Ovr	
Dep Ovr Comment	
Misc Imp Ovr	
Misc Imp Ovr Comment	
Cost to Cure Ovr	
Cost to Cure Ovr Comment	

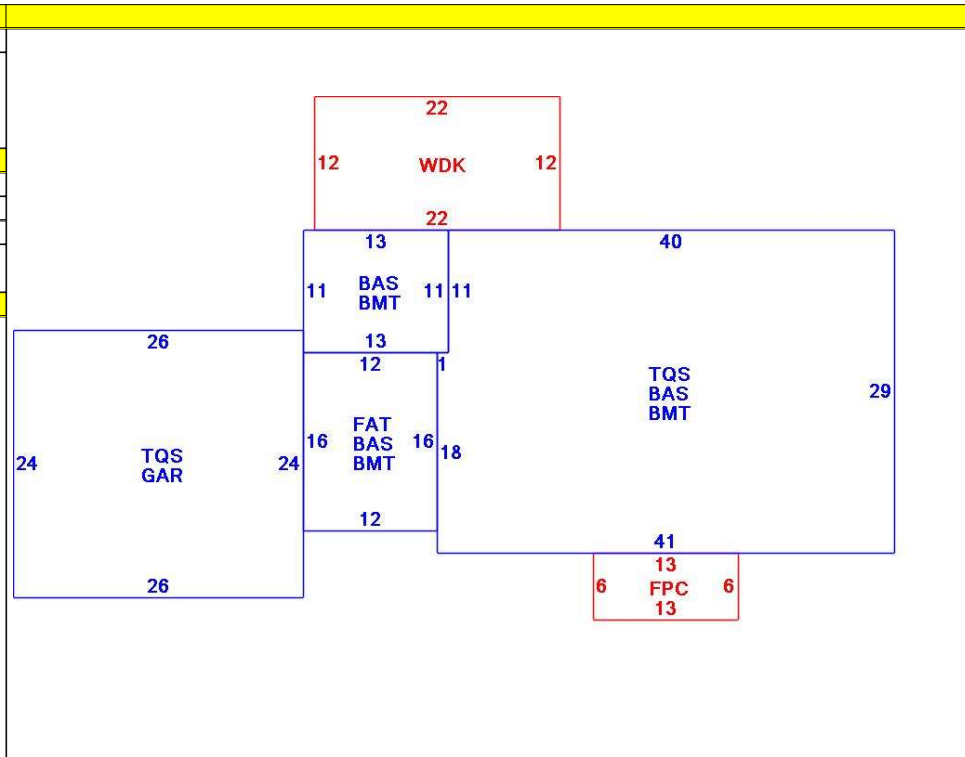

OB - OUTBUILDING & YARD ITEMS(L) / XF - BUILDING EXTRA FEATURES(B)										
Code	Description	L/B	Units	Unit Price	Yr Blt	Cond. Cd	% Gd	Grade	Grade Adj.	Appr. Value
FPL2	Fireplace 1.5 s	B	2	6000.00	2008		90		0.00	10,800
WDC	Wood Decking	L	264	20.00	2005		72		0.00	4,000
FOPC	Open Prch-roo	B	78	55.00	2008		90		0.00	3,500
GAR	Attached Gara	B	624	40.00	2008		90		0.00	19,500
BMT	Basement-Unfi	B	1,513	26.01	2008		90		0.00	32,100

BUILDING SUB-AREA SUMMARY SECTION						
Code	Description	Living Area	Floor Area	Eff Area	Unit Cost	Undeprec Value
BAS	First Floor	1,513	1,513	1,513	259.96	393,324
BMT	Basement Area	0	1,513	0	0.00	0
FAT	Attic, Finished	29	192	29	39.27	7,539
FPC	Open Porch Conc. Floor	0	78	0	0.00	0
GAR	Attached Garage	0	624	0	0.00	0
TQS	Three Quarter Story	1,171	1,802	1,171	168.93	304,417
WDK	Wood Deck	0	264	0	0.00	0
Ttl Gross Liv / Lease Area		2,713	5,986	2,713		705,280

