

CURRENT OWNER		TOPO	UTILITIES	STRT / ROAD	LOCATION	CURRENT ASSESSMENT			
GIANNETTI, JANE TR 24 INDIGO LN OSTERVILLE MA 02655		2 Above Street	2 Public Water	1 Paved		Description	Code	Assessed	Assessed
			4 Gas			RESIDNTL	1010	789,500	789,500
			6 Septic			RES LAND	1010	291,300	291,300
SUPPLEMENTAL DATA									
Alt Prcl ID			Plan Ref.						
Split Zonin			Land Ct# 25575-D (SH 2)						
BID Parcel			#SR						
ResExpt Q			Life Estate						
#DL 1 LOT 15			PP STATU						
#DL 2									
GIS ID F_958165_2699743			Assoc Pid#						
						Total		1,080,800	1,080,800

801
 FY2024
 BARNSTABLE, MA

VISION

RECORD OF OWNERSHIP		BK-VOL/PAGE	SALE DATE	Q/U	V/I	SALE PRIC	VC	PREVIOUS ASSESSMENTS (HISTORY)									
GIANNETTI, JANE TR		C175401	0	12-20-2004	U	I	1	1F	Year	Code	Assessed	Year	Code	Assessed	Year	Code	Assessed
GIANNETTI, JANE		C158889	0	08-31-2000	Q	I	445,000	00	2023	1010	698,300	2022	1010	583,700	2021	1010	489,500
WARNER, ELIZABETH S TR		C151036	0	11-25-1998	U	I	1	1A		1010	288,100		1010	184,600		1010	196,100
WARNER, ELIZABETH S		C133406	0	04-01-1994	Q	I	355,000	00								1010	11,200
RYAN, JOHN A & CAROL BALL		C127532	0	08-17-1992	Q	V	75,000	00									
									Total		986,400	Total		768,300	Total		696,800

EXEMPTIONS			OTHER ASSESSMENTS					
Year	Code	Description	Amount	Code	Description	Number	Amount	Comm Int
2024	N5C	NO RESIDENTIAL EXEMPTION						
			Total				0.00	

This signature acknowledges a visit by a Data Collector or Assessor

ASSESSING NEIGHBORHOOD			
Nbhd	Nbhd Name	B	Tracing
0108			MARSTM

NOTES			

APPRAISED VALUE SUMMARY	
Appraised Bldg. Value (Card)	720,300
Appraised Xf (B) Value (Bldg)	58,000
Appraised Ob (B) Value (Bldg)	11,200
Appraised Land Value (Bldg)	291,300
Special Land Value	0
Total Appraised Parcel Value	1,080,800
Valuation Method	C
Total Appraised Parcel Value	1,080,800

BUILDING PERMIT RECORD									VISIT / CHANGE HISTORY					
Permit Id	Issue Date	Type	Description	Amount	Insp Date	% Comp	Date Comp	Comments	Date	Id	Type	Is	Cd	Purpost/Result
B35407	09-01-1992	DW	Dwelling	150,000	01-15-1994	100	12-31-1994	MM 11/2 S	06-02-2020	DM			FR	Field Review
									04-23-2018	KM	02		03	Cycl Insp Comp
									02-18-2015	JR	03		03	Cycl Insp Comp
									03-30-2006	PT	02		01	Meas/Est
									12-10-1998	FS	01		00	Meas/Listed-Interior Acces
									04-15-1993	ME	02		01	Meas/Est

LAND LINE VALUATION SECTION																	
B	Use Code	Description	Zone	LA	Land Units	Unit Price	Size Adj	AC Disc	Site Index	Cond.	Nbhd.	Nbhd. Adj	Notes	Location Adjustmen	Adj Unit P	Land Value	
1	1010	Single Fam M-0	RF	3	0.730	AC	176,344.00	1.33091	1.0000	5	1.00	0108	1.700		1.0000	398,995.9	291,300
Total Card Land Units					0.73	AC	Parcel Total Land Area					0.73	Total Land Value			291,300	

CONSTRUCTION DETAIL			CONSTRUCTION DETAIL (CONTINUED)		
Element	Cd	Description	Element	Cd	Description
Style	04	Cape Cod			
Model	01	Residential			
Grade:	C+	Average Plus			
Stories	1.75	1 3/4 Stories			
Exterior Wall 1	14	Wood Shingle			
Exterior Wall 2	11	Clapboard			
RooF Structure	03	Gable/Hip			
RooF Cover	03	Asph/F Gls/Cmp			
Interior Wall 1	05	Drywall			
Interior Wall 2					
Interior Floor 1	14	Carpet			
Interior Floor 2	12	Hardwood			
Heat Fuel	03	Gas			
Heat Type	05	Hot Water			
AC Type	03	Central			
Bedrooms	04	4 Bedrooms			
Full Baths	3				
Half Baths	1				
Extra Fixtures					
Total Rooms	9	9 Rooms			
Bath Style					
Kitchen Style					
Occupancy					
Usrflid 105					
Accessory Apt					
Foundation Alt	01	Poured Conc.			
Rms Prts					
Bath Split	31	3 Full-1 Half			
			CONDO DATA		
			Parcel Id	C	Owne 0.0
			Adjust Type Code Description Factor%		
			Condo Flr		
			Condo Unit		
			COST / MARKET VALUATION		
			Building Value New		791,500
			Year Built		1992
			Effective Year Built		2007
			Depreciation Code		G
			Remodel Rating		
			Year Remodeled		
			Depreciation %		9
			Functional Obsol		0
			External Obsol		0
			Trend Factor		1
			Condition		
			Condition %		
			Percent Good		91
			RCNLD		720,300
			Dep % Ovr		
			Dep Ovr Comment		
			Misc Imp Ovr		
			Misc Imp Ovr Comment		
			Cost to Cure Ovr		
			Cost to Cure Ovr Comment		

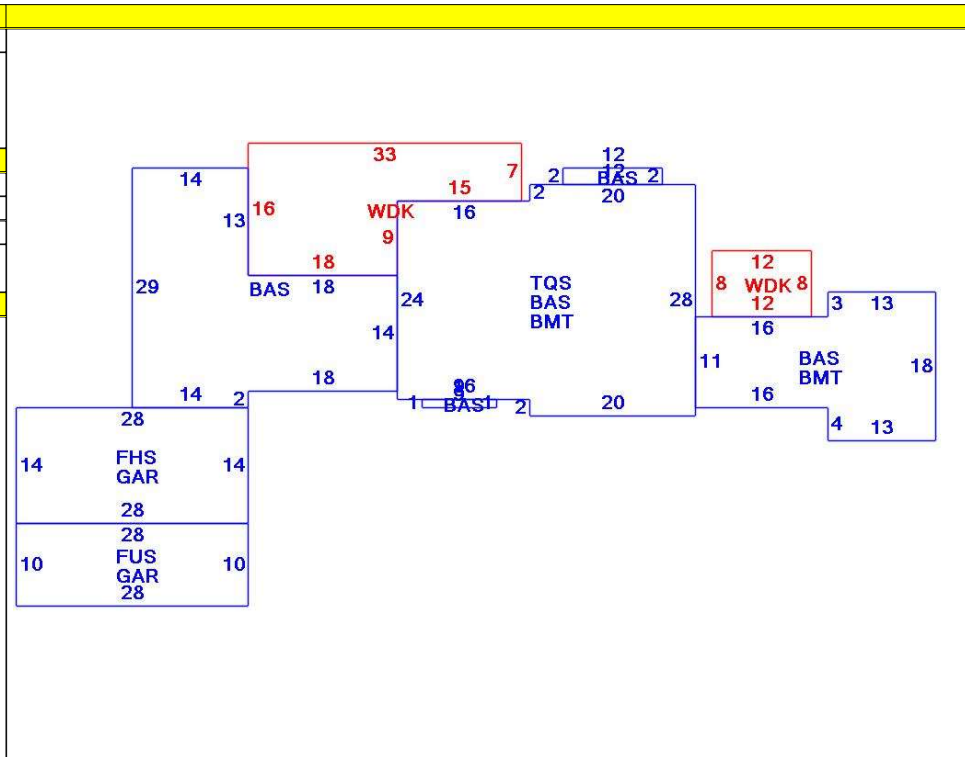

OB - OUTBUILDING & YARD ITEMS(L) / XF - BUILDING EXTRA FEATURES(B)										
Code	Description	L/B	Units	Unit Price	Yr Blt	Cond. Cd	% Gd	Grade	Grade Adj.	Appr. Value
FPL2	Fireplace 1.5 s	B	1	6000.00	2009		91		0.00	5,500
FPO	Ext FP Openin	B	1	2000.00	2009		91		0.00	1,800
WDC	Wood Decking	L	489	20.00	2001		64		0.00	5,900
GAR	Attached Gara	B	672	40.00	2009		91		0.00	20,800
BMT	Basement-Unfi	B	1,354	26.01	2009		91		0.00	29,900
GEN	Emergency Ge	L	1	5550.00	2017		96		0.00	5,300

BUILDING SUB-AREA SUMMARY SECTION						
Code	Description	Living Area	Floor Area	Eff Area	Unit Cost	Undeprec Value
BAS	First Floor	2,045	2,045	2,045	252.47	516,305
BMT	Basement Area	0	1,354	0	0.00	0
FHS	Half Story	196	392	196	126.24	49,485
FUS	Upper Story	280	280	280	252.47	70,692
GAR	Attached Garage	0	672	0	0.00	0
TQS	Three Quarter Story	614	944	614	164.21	155,018
WDK	Wood Deck	0	489	0	0.00	0
Ttl Gross Liv / Lease Area		3,135	6,176	3,135		791,500

