

CURRENT OWNER			TOPO		UTILITIES		STRT / ROAD		LOCATION		CURRENT ASSESSMENT				801 FY2024 BARNSTABLE, MA VISION
HILL, ANNA E TR HILL FAMILY TRUST 80 PINE HILL CIR WALTHAM MA 02454			1	Level	6	Septic	1	Paved			Description	Code	Assessed	Assessed	
					2	Public Water					RESIDENTL	1010	357,300	357,300	
SUPPLEMENTAL DATA											RES LAND	1010	157,200	157,200	
Alt Prcl ID			Split Zonin			Plan Ref. 269/41									
WALTHAM MA 02454			#DL 1 LOT 3			Land Ct#									
WALTHAM MA 02454			#DL 2			#SR									
GIS ID F_956160_2708879			Assoc Pid#			Life Estate									
GIS ID F_956160_2708879			Assoc Pid#			PP STATU									
											Total		514,500	514,500	

RECORD OF OWNERSHIP			BK-VOL/PAGE		SALE DATE		Q/U		V/I		SALE PRIC		VC		PREVIOUS ASSESSMENTS (HISTORY)						
HILL, ANNA E TR GODDARD, HAROLD C & MARY E			12669	0232	11-17-1999		Q	I			144,500	00	Year	Code	Assessed	Year	Code	Assessed	Year	Code	Assessed
			2485	0198	03-28-1977		U				0		2023	1010	308,200	2022	1010	266,800	2021	1010	218,200
											0		1010	142,900	1010	105,800	1010	105,800	1010	2,100	
											Total		451,100	Total		372,600	Total		326,100		

EXEMPTIONS				OTHER ASSESSMENTS				This signature acknowledges a visit by a Data Collector or Assessor											
Year	Code	Description	Amount	Code	Description	Number	Amount												
			Total	0.00															

ASSESSING NEIGHBORHOOD				APPRAISED VALUE SUMMARY				
Nbhd	Nbhd Name	B	Tracing	Batch				
0105				MARSTM				
NOTES				Appraised Bldg. Value (Card)				308,400
				Appraised Xf (B) Value (Bldg)				46,800
				Appraised Ob (B) Value (Bldg)				2,100
				Appraised Land Value (Bldg)				157,200
				Special Land Value				0
				Total Appraised Parcel Value				514,500
				Valuation Method				C
				Total Appraised Parcel Value				514,500

BUILDING PERMIT RECORD									VISIT / CHANGE HISTORY					
Permit Id	Issue Date	Type	Description	Amount	Insp Date	% Comp	Date Comp	Comments	Date	Id	Type	Is	Cd	Purpost/Result
201408207	12-11-2014	IN	Insulation	4,600	06-30-2015	100	06-30-2016	WEATHERIZATION	05-15-2020	LS			FR	Field Review
B17726	06-01-1975	DW	Dwelling	0	01-15-1976	100	12-31-1976	MM 1 STOR	04-30-2018	KM	02		03	Cycl Insp Comp
									07-12-2006	PT	02		01	Meas/Est
									06-26-1999	DD	01		00	Meas/Listed-Interior Acces

LAND LINE VALUATION SECTION																			
B	Use Code	Description	Zone	LA	Land Units	Unit Price	Size Adj	AC Disc	Site Index	Cond.	Nbhd.	Nbhd. Adj	Notes	Location Adjustmen	Adj Unit P	Land Value			
1	1010	Single Fam M-0	RF	3	0.500	AC	176,344.00	1.78240	1.0000	5	1.00	0105	1.000		1.0000	314,315.5	157,200		
					Total Card Land Units	0.50	AC	Parcel Total Land Area					0.50	Total Land Value					157,200

CONSTRUCTION DETAIL			CONSTRUCTION DETAIL (CONTINUED)		
Element	Cd	Description	Element	Cd	Description
Style	01	Ranch			
Model	01	Residential			
Grade:	C	Average			
Stories	1	1 Story			
Exterior Wall 1	25	Vinyl Siding			
Exterior Wall 2					
RooF Structure	03	Gable/Hip			
RooF Cover	03	Asph/F Gls/Cmp			
Interior Wall 1	05	Drywall			
Interior Wall 2					
Interior Floor 1	12	Hardwood			
Interior Floor 2					
Heat Fuel	02	Oil			
Heat Type	04	Hot Air			
AC Type	01	None			
Bedrooms	02	2 Bedrooms			
Full Baths	1				
Half Baths	1				
Extra Fixtures					
Total Rooms	5	5 Rooms			
Bath Style					
Kitchen Style					
Occupancy					
Usrflid 105					
Accessory Apt					
Foundation Alt	01	Poured Conc.			
Rms Prts					
Bath Split	11	1 Full-1 Half			

CONDO DATA			
Parcel Id		C	Owne 0.0
		B	S
Adjust Type	Code	Description	Factor%
Condo Flr			
Condo Unit			

COST / MARKET VALUATION	
Building Value New	367,105
Year Built	1975
Effective Year Built	1998
Depreciation Code	G
Remodel Rating	
Year Remodeled	
Depreciation %	16
Functional Obsol	0
External Obsol	0
Trend Factor	1
Condition	
Condition %	
Percent Good	84
RCNLD	308,400
Dep % Ovr	
Dep Ovr Comment	
Misc Imp Ovr	
Misc Imp Ovr Comment	
Cost to Cure Ovr	
Cost to Cure Ovr Comment	

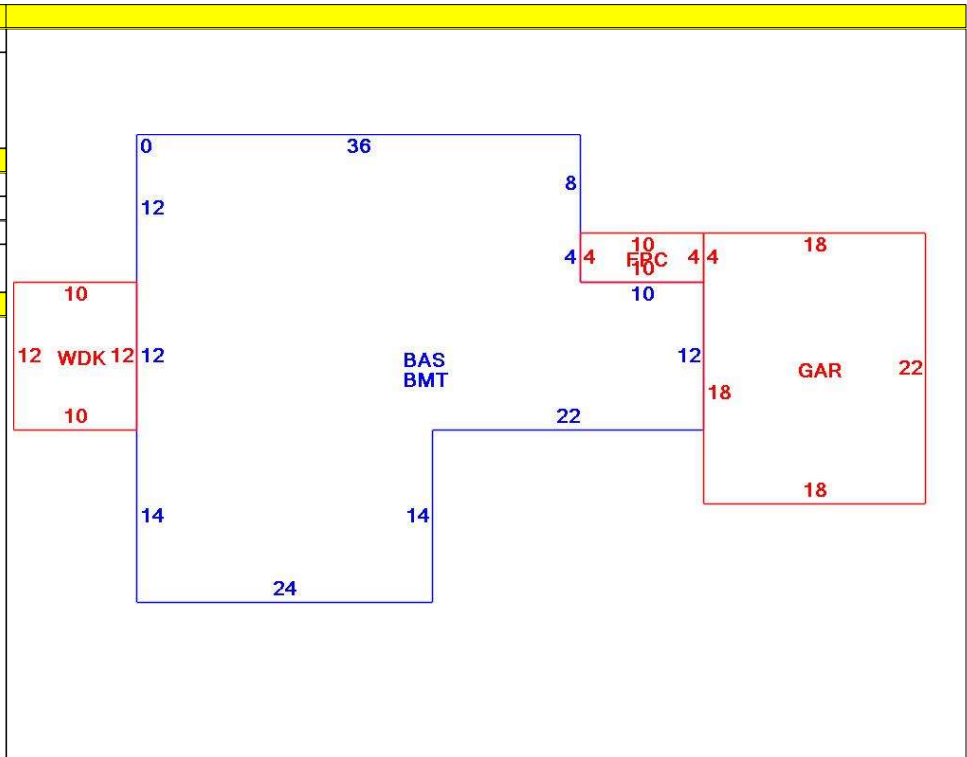

OB - OUTBUILDING & YARD ITEMS(L) / XF - BUILDING EXTRA FEATURES(B)										
Code	Description	L/B	Units	Unit Price	Yr Blt	Cond. Cd	% Gd	Grade	Grade Adj.	Appr. Value
FPL1	Fireplace 1 sto	B	1	5000.00	2000		84		0.00	4,200
WDC	Wood Decking	L	120	20.00	1997		56		0.00	2,100
FOPC	Open Prch-roo	B	40	55.00	2000		84		0.00	2,100
GAR	Attached Gara	B	396	40.00	2000		84		0.00	13,400
BMT	Basement-Unfi	B	1,320	26.01	2000		84		0.00	27,100

BUILDING SUB-AREA SUMMARY SECTION						
Code	Description	Living Area	Floor Area	Eff Area	Unit Cost	Undeprec Value
BAS	First Floor	1,320	1,320	1,320	278.11	367,105
BMT	Basement Area	0	1,320	0	0.00	0
FPC	Open Porch Conc. Floor	0	40	0	0.00	0
GAR	Attached Garage	0	396	0	0.00	0
WDK	Wood Deck	0	120	0	0.00	0
Ttl Gross Liv / Lease Area		1,320	3,196	1,320		367,105

