

CURRENT OWNER		TOPO	UTILITIES	STRT / ROAD	LOCATION	CURRENT ASSESSMENT				801 FY2024 BARNSTABLE, MA VISION
BIRCH, JEAN A 151 ROSELAND TERRACE MARSTONS MIL MA 02648		1 Level	6 Septic			Description	Code	Assessed	Assessed	
			2 Public Water			RESIDNTL	1010	349,100	349,100	
SUPPLEMENTAL DATA						RES LAND	1010	155,900	155,900	
Alt Prcl ID		Split Zonin		Plan Ref. 269/41		Total				
BID Parcel		ResExpt Q YES:		Land Ct#						
#DL 1 LOT 14		#DL 2		Life Estate						
GIS ID F_955860_2709232		Assoc Pid#		PP STATU						

RECORD OF OWNERSHIP		BK-VOL/PAGE	SALE DATE	Q/U	V/I	SALE PRIC	VC	PREVIOUS ASSESSMENTS (HISTORY)								
BIRCH, JEAN A		P0953EP	08-15-1994	U	I	1	A	Year	Code	Assessed	Year	Code	Assessed	Year	Code	Assessed
BIRCH, KENNETH J & JEAN A		2897 0032	04-06-1979	U		0		2023	1010	311,000	2022	1010	266,000	2021	1010	225,100
									1010	141,700		1010	105,000		1010	105,000
															1010	6,200
								Total		452,700	Total		371,000	Total		336,300

EXEMPTIONS			OTHER ASSESSMENTS					APPRAISED VALUE SUMMARY					
Year	Code	Description	Amount	Code	Description	Number	Amount	Comm Int	This signature acknowledges a visit by a Data Collector or Assessor				
2024	5C	RESIDENTIAL EXEMPTION							Appraised Bldg. Value (Card) 301,700				
Total			0.00						Appraised Xf (B) Value (Bldg) 41,200				

ASSESSING NEIGHBORHOOD			NOTES			
Nbhd	Nbhd Name	B	Tracing			Batch
0105						MARSTM

BUILDING PERMIT RECORD									VISIT / CHANGE HISTORY					
Permit Id	Issue Date	Type	Description	Amount	Insp Date	% Comp	Date Comp	Comments	Date	Id	Type	Is	Cd	Purpost/Result
B31425	11-01-1987	AD	Addition	13,425	01-15-1989	100	12-31-1989	MM GARAGE	08-03-2023	EG	03		16	In Office Review
B20482	08-01-1978	DW	Dwelling	0	01-15-1980	100	12-31-1980	MM 1 STOR	05-07-2020	LS			FR	Field Review
									04-30-2018	KM	02		03	Cycl Insp Comp
									09-23-2015	AL	03		16	In Office Review
									03-24-2014	JR	03		16	In Office Review
									07-12-2006	PT	02		01	Meas/Est
									04-29-1999	DD	01		00	Meas/Listed-Interior Acces

LAND LINE VALUATION SECTION																	
B	Use Code	Description	Zone	LA	Land Units	Unit Price	Size Adj	AC Disc	Site Index	Cond.	Nbhd.	Nbhd. Adj	Notes	Location Adjustmen	Adj Unit P	Land Value	
1	1010	Single Fam M-0	RF	3	0.460 AC	176,344.00	1.92125	1.0000	5	1.00	0105	1.000		1.0000	338,809.7	155,900	
Total Card Land Units					0.46 AC	Parcel Total Land Area					0.46	Total Land Value					155,900

CONSTRUCTION DETAIL			CONSTRUCTION DETAIL (CONTINUED)		
Element	Cd	Description	Element	Cd	Description
Style	04	Cape Cod			
Model	01	Residential			
Grade:	C	Average			
Stories	1	1 Story			
Exterior Wall 1	25	Vinyl Siding			
Exterior Wall 2					
Roof Structure	03	Gable/Hip			
Roof Cover	03	Asph/F Gls/Cmp			
Interior Wall 1	05	Drywall			
Interior Wall 2					
Interior Floor 1	14	Carpet			
Interior Floor 2					
Heat Fuel	02	Oil			
Heat Type	04	Hot Air			
AC Type	01	None			
Bedrooms	03	3 Bedrooms			
Full Baths	1				
Half Baths	1				
Extra Fixtures					
Total Rooms	6	6 Rooms			
Bath Style					
Kitchen Style					
Occupancy					
Usrflid 105					
Accessory Apt					
Foundation Alt	01	Poured Conc.			
Rms Prts					
Bath Split	11	1 Full-1 Half			

CONDO DATA				
Parcel Id		C		Owne 0.0
			B	S
Adjust Type	Code	Description	Factor%	
Condo Flr				
Condo Unit				

COST / MARKET VALUATION	
Building Value New	372,515
Year Built	1978
Effective Year Built	1995
Depreciation Code	A
Remodel Rating	
Year Remodeled	
Depreciation %	19
Functional Obsol	0
External Obsol	0
Trend Factor	1
Condition	
Condition %	
Percent Good	81
RCNLD	301,700
Dep % Ovr	
Dep Ovr Comment	
Misc Imp Ovr	
Misc Imp Ovr Comment	
Cost to Cure Ovr	
Cost to Cure Ovr Comment	

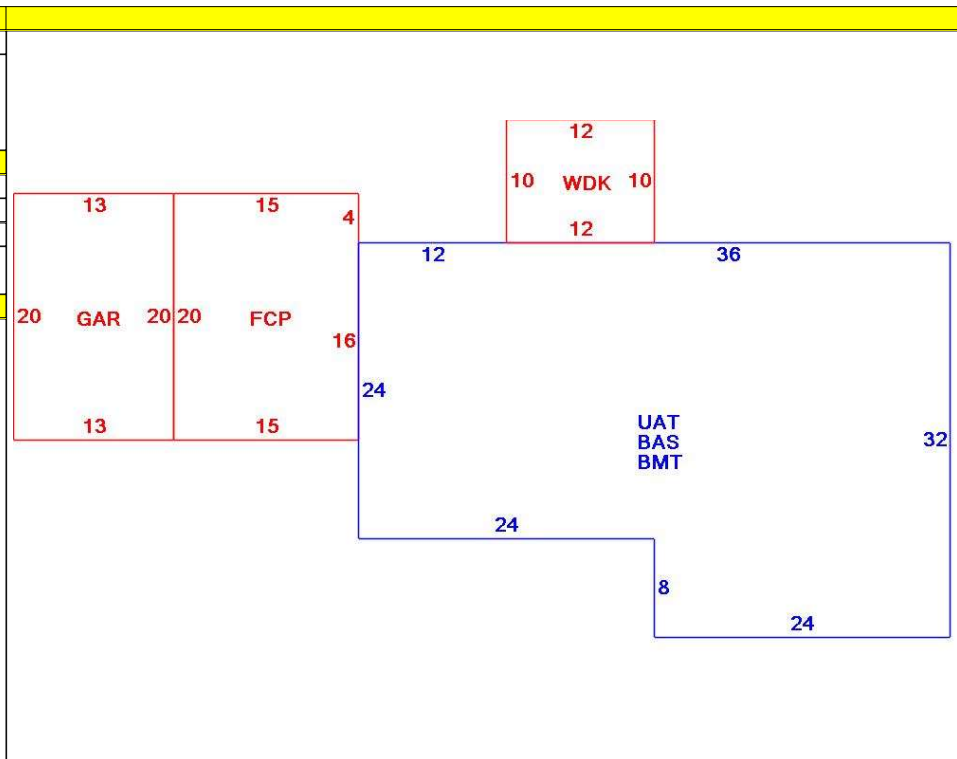

OB - OUTBUILDING & YARD ITEMS(L) / XF - BUILDING EXTRA FEATURES(B)										
Code	Description	L/B	Units	Unit Price	Yr Blt	Cond. Cd	% Gd	Grade	Grade Adj.	Appr. Value
FPL2	Fireplace 1.5 s	B	1	6000.00	1997		81		0.00	4,900
FCP	Carport - flat r	L	300	15.25	1999		80		0.00	3,700
WDC	Deck composit	L	120	24.00	1997		56		0.00	2,500
GAR	Attached Gara	B	260	40.00	1997		81		0.00	9,800
BMT	Basement-Unfi	B	1,344	26.01	1997		81		0.00	26,500

BUILDING SUB-AREA SUMMARY SECTION						
Code	Description	Living Area	Floor Area	Eff Area	Unit Cost	Undeprec Value
BAS	First Floor	1,344	1,344	1,344	252.04	338,742
BMT	Basement Area	0	1,344	0	0.00	0
FCP	Carport	0	300	0	0.00	0
GAR	Attached Garage	0	260	0	0.00	0
UAT	Attic, Unfinished	0	1,344	134	25.13	33,773
WDK	Wood Deck	0	120	0	0.00	0
Ttl Gross Liv / Lease Area		1,344	4,712	1,478		372,515

