

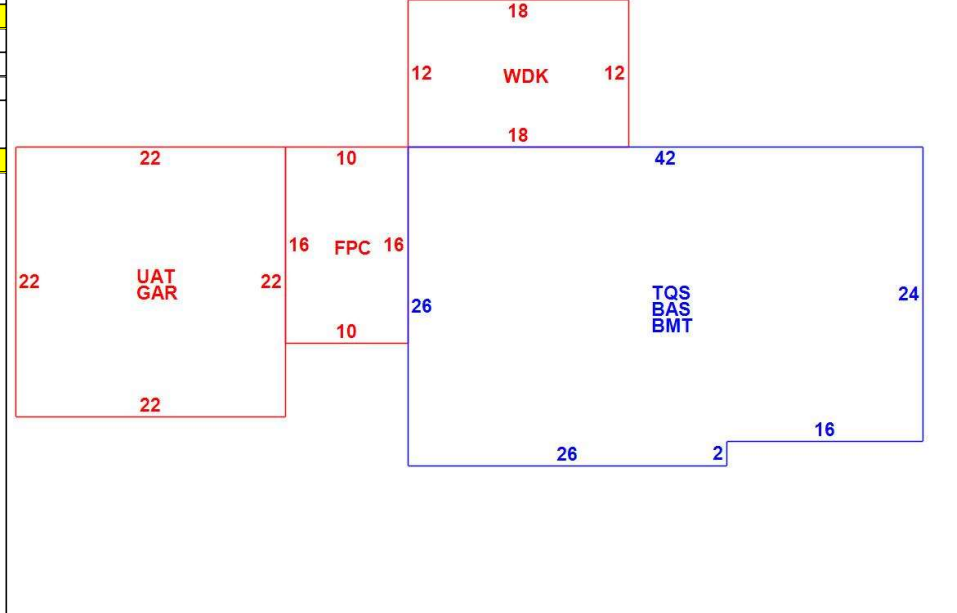

CONSTRUCTION DETAIL			CONSTRUCTION DETAIL (CONTINUED)		
Element	Cd	Description	Element	Cd	Description
Style	04	Cape Cod			
Model	01	Residential			
Grade:	C	Average			
Stories	1.75	1 3/4 Stories			
Exterior Wall 1	14	Wood Shingle			
Exterior Wall 2	11	Clapboard			
RooF Structure	03	Gable/Hip			
RooF Cover	03	Asph/F Gls/Cmp			
Interior Wall 1	05	Drywall			
Interior Wall 2					
Interior Floor 1	12	Hardwood			
Interior Floor 2	14	Carpet			
Heat Fuel	03	Gas			
Heat Type	04	Hot Air			
AC Type	03	Central			
Bedrooms	03	3 Bedrooms			
Full Baths	2				
Half Baths	0				
Extra Fixtures					
Total Rooms	6	6 Rooms			
Bath Style					
Kitchen Style					
Occupancy					
Usrflid 105					
Accessory Apt					
Foundation Alt	01	Poured Conc.			
Rms Prts					
Bath Split	20	2 Full-0 Half			

CONDO DATA			
Parcel Id		C	Owne 0.0
		B	S
Adjust Type	Code	Description	Factor%
Condo Flr			
Condo Unit			

COST / MARKET VALUATION	
Building Value New	461,470
Year Built	1976
Effective Year Built	1994
Depreciation Code	A
Remodel Rating	
Year Remodeled	
Depreciation %	19
Functional Obsol	0
External Obsol	0
Trend Factor	1
Condition	
Condition %	
Percent Good	81
RCNLD	373,800
Dep % Ovr	
Dep Ovr Comment	
Misc Imp Ovr	
Misc Imp Ovr Comment	
Cost to Cure Ovr	
Cost to Cure Ovr Comment	



OB - OUTBUILDING & YARD ITEMS(L) / XF - BUILDING EXTRA FEATURES(B)										
Code	Description	L/B	Units	Unit Price	Yr Blt	Cond. Cd	% Gd	Grade	Grade Adj.	Appr. Value
FPL2	Fireplace 1.5 s	B	1	6000.00	1996		81		0.00	4,900
WDC	Wood Deck w/	L	216	18.00	1997		56		0.00	2,500
FOPC	Open Prch-roo	B	160	55.00	1996		81		0.00	5,200
GAR	Attached Gara	B	484	40.00	1996		81		0.00	14,700
BMT	Basement-Unfi	B	1,060	26.01	1996		81		0.00	22,400
GEN	Emergency Ge	L	1	5550.00	2023		100		0.00	5,600
SHED	Shed	L	112	18.00	2023		100		0.00	2,000

BUILDING SUB-AREA SUMMARY SECTION						
Code	Description	Living Area	Floor Area	Eff Area	Unit Cost	Undeprec Value
BAS	First Floor	1,060	1,060	1,060	256.80	272,208
BMT	Basement Area	0	1,060	0	0.00	0
FPC	Open Porch Conc. Floor	0	160	0	0.00	0
GAR	Attached Garage	0	484	0	0.00	0
TQS	Three Quarter Story	689	1,060	689	166.92	176,935
UAT	Attic, Unfinished	0	484	48	25.47	12,326
WDK	Wood Deck	0	216	0	0.00	0
Ttl Gross Liv / Lease Area		1,749	4,524	1,797		461,469

