

| CURRENT OWNER | | TOPO | UTILITIES | STRT / ROAD | LOCATION | CURRENT ASSESSMENT | | | | |
|---|--|------|-----------|--|----------|--------------------|------|----------|----------|---------------------------------|
| BASSING, HENRY E & MARY T | | | | | | Description | Code | Assessed | Assessed | 801 FY2024 BARNSTABLE, MA |
| 254 HIGH ST | | | | | | RESIDNTL | 1010 | 541,000 | 541,000 | |
| WEST BARNSTA MA 02668 | | | | | | RES LAND | 1010 | 252,100 | 252,100 | VISION |
| SUPPLEMENTAL DATA | | | | | | Total | | | | |
| Alt Prcl ID Split Zonin BID Parcel ResExpt Q YES: #DL 1 LOT 3 #DL 2 GIS ID F_957836_2725372 | | | | Plan Ref. 291/44 Land Ct# #SR Life Estate PP STATU Assoc Pid# | | 793,100 | | | | |

| RECORD OF OWNERSHIP | | BK-VOL/PAGE | SALE DATE | Q/U | V/I | SALE PRIC | VC | PREVIOUS ASSESSMENTS (HISTORY) | | | | | |
|---------------------------|--|-------------|------------|-----|-----|-----------|----|--------------------------------|------|----------|-------|------|----------|
| BASSING, MARY T TR | | 35893 171 | 07-17-2023 | U | I | 100 | 1F | Year | Code | Assessed | Year | Code | Assessed |
| BASSING, MARY T | | 35893 165 | 04-13-2023 | U | I | 0 | 1F | 2023 | 1010 | 485,300 | 2022 | 1010 | 408,100 |
| BASSING, HENRY E & MARY T | | 12086 0287 | 02-25-1999 | U | I | 149,000 | 2 | | 1010 | 229,600 | 2021 | 1010 | 159,200 |
| TALSI CONSTRUCTION CORP | | 4011 0159 | 02-09-1984 | U | I | 30,000 | G | Total | | 714,900 | Total | | 567,300 |
| | | | | | | | | Total | | 514,100 | Total | | 514,100 |

| EXEMPTIONS | | | | OTHER ASSESSMENTS | | | | This signature acknowledges a visit by a Data Collector or Assessor | | | | |
|------------|------|-----------------------|--------|-------------------|-------------|--------|--------|---|--|--|--|--|
| Year | Code | Description | Amount | Code | Description | Number | Amount | Comm Int | | | | |
| 2014 | 5C | RESIDENTIAL EXEMPTION | 0.00 | | | | | | | | | |
| Total | | | 0.00 | | | | | | | | | |

| ASSESSING NEIGHBORHOOD | | | | APPRAISED VALUE SUMMARY | | | |
|------------------------|-----------|---|---------|-------------------------|--|--|--|
| Nbhd | Nbhd Name | B | Tracing | Batch | | | |
| 0107 | | | WBARNS | | | | |

| NOTES | | | | VISIT / CHANGE HISTORY | | | | | |
|-------|--|--|--|------------------------------|-----|------|----|---------|----------------------------|
| | | | | Date | Id | Type | Is | Cd | Purpost/Result |
| | | | | 05-19-2020 | DM | | | FR | Field Review |
| | | | | 12-23-2016 | SR | 01 | | 03 | Cycl Insp Comp |
| | | | | 07-29-2013 | GC | 03 | | 16 | In Office Review |
| | | | | 09-27-2011 | RB | 03 | | 16 | In Office Review |
| | | | | 07-10-2007 | KLP | 03 | | 16 | In Office Review |
| | | | | 08-21-2006 | PT | 02 | | 14 | Cyclical Inspection |
| | | | | 06-21-2006 | MF | 01 | | 00 | Meas/Listed-Interior Acces |
| | | | | Total Appraised Parcel Value | | | | 793,100 | |

| BUILDING PERMIT RECORD | | | | | | | | VISIT / CHANGE HISTORY | | | | | | | |
|------------------------|------------|------|-------------|---------|------------|--------|------------|------------------------|------------|-----|------|----|----|----------------------------|--|
| Permit Id | Issue Date | Type | Description | Amount | Insp Date | % Comp | Date Comp | Comments | Date | Id | Type | Is | Cd | Purpost/Result | |
| 82566 | 03-04-2005 | DW | Dwelling | 200,000 | 06-27-2006 | 100 | 01-01-2006 | | 05-19-2020 | DM | | | FR | Field Review | |
| | | | | | | | | | 12-23-2016 | SR | 01 | | 03 | Cycl Insp Comp | |
| | | | | | | | | | 07-29-2013 | GC | 03 | | 16 | In Office Review | |
| | | | | | | | | | 09-27-2011 | RB | 03 | | 16 | In Office Review | |
| | | | | | | | | | 07-10-2007 | KLP | 03 | | 16 | In Office Review | |
| | | | | | | | | | 08-21-2006 | PT | 02 | | 14 | Cyclical Inspection | |
| | | | | | | | | | 06-21-2006 | MF | 01 | | 00 | Meas/Listed-Interior Acces | |

| LAND LINE VALUATION SECTION | | | | | | | | | | | | | | | | |
|-----------------------------|----------|----------------|------|----|------------|---------------|------------------------|---------|------------|-------|-------|-----------|------------------|--------------------|------------|------------|
| B | Use Code | Description | Zone | LA | Land Units | Unit Price | Size Adj | AC Disc | Site Index | Cond. | Nbhd. | Nbhd. Adj | Notes | Location Adjustmen | Adj Unit P | Land Value |
| 1 | 1010 | Single Fam M-0 | RF | 5 | 1.000 | AC 176,344.00 | 1.00000 | 1.0000 | 5 | 1.00 | 0107 | 1.400 | | 1.0000 | 246,881.6 | 246,900 |
| 1 | 1010 | Single Fam M-0 | RF | 5 | 0.260 | AC 14,250.00 | 1.00000 | 1.0000 | 0 | 1.00 | 0107 | 1.400 | | 1.0000 | 19,950 | 5,200 |
| Total Card Land Units | | | | | 1.26 | AC | Parcel Total Land Area | | | | | 1.26 | Total Land Value | | | 252,100 |

| CONSTRUCTION DETAIL | | | CONSTRUCTION DETAIL (CONTINUED) | | |
|---------------------|------|----------------|---------------------------------|----|-------------|
| Element | Cd | Description | Element | Cd | Description |
| Style | 04 | Cape Cod | | | |
| Model | 01 | Residential | | | |
| Grade: | C+ | Average Plus | | | |
| Stories | 1.75 | 1 3/4 Stories | | | |
| Exterior Wall 1 | 14 | Wood Shingle | | | |
| Exterior Wall 2 | 12 | Cedar or Redwd | | | |
| RooF Structure | 03 | Gable/Hip | | | |
| RooF Cover | 03 | Asph/F Gls/Cmp | | | |
| Interior Wall 1 | 03 | Plastered | | | |
| Interior Wall 2 | | | | | |
| Interior Floor 1 | 09 | Pine/Soft Wood | | | |
| Interior Floor 2 | | | | | |
| Heat Fuel | 03 | Gas | | | |
| Heat Type | 04 | Hot Air | | | |
| AC Type | 03 | Central | | | |
| Bedrooms | 04 | 4 Bedrooms | | | |
| Full Baths | 2 | | | | |
| Half Baths | 1 | | | | |
| Extra Fixtures | | | | | |
| Total Rooms | 7 | | | | |
| Bath Style | | | | | |
| Kitchen Style | | | | | |
| Occupancy | | | | | |
| Usrflid 105 | | | | | |
| Accessory Apt | | | | | |
| Foundation Alt | 01 | Poured Conc. | | | |
| Rms Prts | | | | | |
| Bath Split | 21 | 2 Full-1 Half | | | |

| CONDO DATA | | | | |
|-------------|------|-------------|---------|----------|
| Parcel Id | | C | | Ownr 0.0 |
| | | | B | S |
| Adjust Type | Code | Description | Factor% | |
| Condo Flr | | | | |
| Condo Unit | | | | |

| COST / MARKET VALUATION | | |
|--------------------------|---------|---------|
| Building Value New | | 527,136 |
| Year Built | 2005 | |
| Effective Year Built | 2008 | |
| Depreciation Code | A | |
| Remodel Rating | | |
| Year Remodeled | | |
| Depreciation % | 9 | |
| Functional Obsol | 0 | |
| External Obsol | 0 | |
| Trend Factor | 1 | |
| Condition | | |
| Condition % | | |
| Percent Good | 91 | |
| RCNLD | 479,700 | |
| Dep % Ovr | | |
| Dep Ovr Comment | | |
| Misc Imp Ovr | | |
| Misc Imp Ovr Comment | | |
| Cost to Cure Ovr | | |
| Cost to Cure Ovr Comment | | |

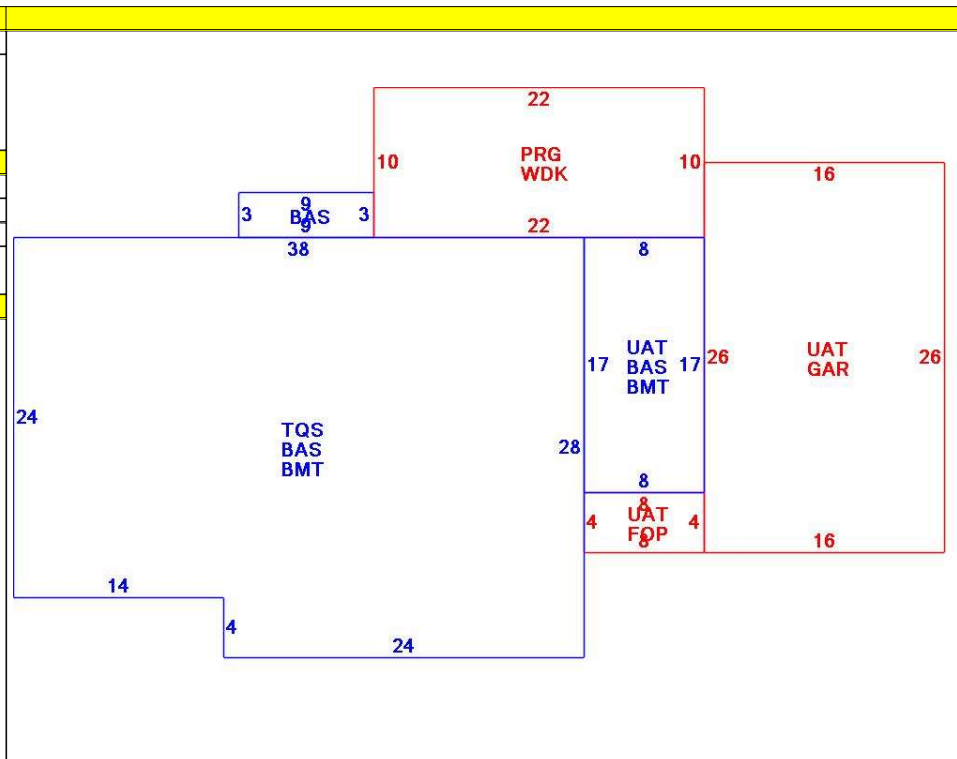

| OB - OUTBUILDING & YARD ITEMS(L) / XF - BUILDING EXTRA FEATURES(B) | | | | | | | | | | |
|--|-----------------|-----|-------|------------|--------|----------|------|-------|------------|-------------|
| Code | Description | L/B | Units | Unit Price | Yr Blt | Cond. Cd | % Gd | Grade | Grade Adj. | Appr. Value |
| FPL2 | Fireplace 1.5 s | B | 1 | 6000.00 | 2010 | | 91 | | 0.00 | 5,500 |
| WDC | Wood Decking | L | 220 | 20.00 | 2008 | | 78 | | 0.00 | 3,900 |
| FOP | Open Porch-ro | B | 32 | 55.00 | 2010 | | 91 | | 0.00 | 2,300 |
| GAR | Attached Gara | B | 416 | 40.00 | 2010 | | 91 | | 0.00 | 15,000 |
| BMT | Basement-Unfi | B | 1,144 | 26.01 | 2010 | | 91 | | 0.00 | 26,400 |
| PRG1 | Pergola-Avg | L | 220 | 18.00 | 2008 | | 78 | C | 1.00 | 3,100 |
| GEN | Emergency Ge | L | 1 | 5550.00 | 2015 | | 92 | | 0.00 | 5,100 |

| BUILDING SUB-AREA SUMMARY SECTION | | | | | | |
|-----------------------------------|---------------------|-------------|------------|----------|-----------|----------------|
| Code | Description | Living Area | Floor Area | Eff Area | Unit Cost | Undeprec Value |
| BAS | First Floor | 1,171 | 1,171 | 1,171 | 279.80 | 327,641 |
| BMT | Basement Area | 0 | 1,144 | 0 | 0.00 | 0 |
| FOP | Open Porch | 0 | 32 | 0 | 0.00 | 0 |
| GAR | Attached Garage | 0 | 416 | 0 | 0.00 | 0 |
| PRG | Pergola | 0 | 220 | 0 | 0.00 | 0 |
| TQS | Three Quarter Story | 655 | 1,008 | 655 | 181.81 | 183,266 |
| UAT | Attic, Unfinished | 0 | 584 | 58 | 27.79 | 16,228 |
| WDK | Wood Deck | 0 | 220 | 0 | 0.00 | 0 |
| Ttl Gross Liv / Lease Area | | 1,826 | 4,795 | 1,884 | | 527,135 |

