

| CURRENT OWNER  |         | TOPO                | UTILITIES | STRT / ROAD                | LOCATION | CURRENT ASSESSMENT |      |          |          | 801<br>FY2024<br>BARNSTABLE, MA<br><br><b>VISION</b> |           |
|--|---------|---------------------|-----------|----------------------------|----------|--------------------|------|----------|----------|--|-----------|
| RYLEY, JOHN STODDARD & GALEN<br><br>35 QUAIL ROAD<br><br>OSTERVILLE MA 02655 | 1 Level | 6 Septic            | 1 Paved   |                            |          | Description        | Code | Assessed | Assessed |  |           |
|  |         | 4 Gas               |           |                            |          | RESIDNTL           | 1010 | 648,600  | 648,600  |  |           |
|  |         | 2 Public Water      |           |                            |          | RES LAND           | 1010 | 527,900  | 527,900  |  |           |
| <b>SUPPLEMENTAL DATA</b>   |         |                     |           |                            |          | Total              |      |          |          | 1,176,500  | 1,176,500 |
| Alt Prcl ID  |         | Split Zonin RC;RF-1 |           | Plan Ref. Land Ct# 26772-S |          |                    |      |          |          |  |           |
| BID Parcel   |         | ResExpt Q           |           | #SR                        |          |                    |      |          |          |  |           |
| #DL 1 LOT 24   |         | #DL 2               |           | Life Estate PP STATU       |          |                    |      |          |          |  |           |
| GIS ID F_959029_2691890  |         | Assoc Pid#          |           |                            |          |                    |      |          |          |  |           |

| RECORD OF OWNERSHIP              |         | BK-VOL/PAGE | SALE DATE  | Q/U  | V/I      | SALE PRIC | VC   | PREVIOUS ASSESSMENTS (HISTORY) |      |         |          |         |         |          |      |         |
|----------------------------------|---------|-------------|------------|------|----------|-----------|------|--------------------------------|------|---------|----------|---------|---------|----------|------|---------|
| Year                             | Code    | Assessed    | Year       | Code | Assessed | Year      | Code | Assessed                       | Year | Code    | Assessed | Year    | Code    | Assessed |      |         |
| RYLEY, JOHN STODDARD & GALEN LAR | C212704 | 0           | 04-28-2017 | Q    | I        | 777,500   | 00   |                                |      |         |          |         |         |          |      |         |
| CURLEY, MARK C & JENNIFER A      | C207402 | 0           | 09-17-2015 | Q    | I        | 730,000   | 00   | 2023                           | 1010 | 578,400 | 2022     | 1010    | 512,800 | 2021     | 1010 | 347,000 |
| MCCORMICK, JAMES W TR            | C134679 | 0           | 08-15-1994 | Q    | I        | 375,000   | U    |                                | 1010 | 621,500 |          | 1010    | 349,600 |          | 1010 | 373,000 |
| MCCARTHY, DAVID L & CAROLA       | C96123  | 0           | 04-15-1984 | Q    | I        | 206,000   | U    |                                |      |         |          |         |         |          | 1010 | 88,200  |
| GLYNN, NEIL H & ARLENE T         | C38023  | 0           | 06-01-1966 | U    |          | 0         |      |                                |      |         |          |         |         |          |      |         |
| Total                            |         |             |            |      |          |           |      | 1,199,900                      |      | Total   |          | 862,400 |         | Total    |      | 808,200 |

| EXEMPTIONS |      |             |        | OTHER ASSESSMENTS |             |        |        | This signature acknowledges a visit by a Data Collector or Assessor |  |  |  |  |  |  |  |  |
|------------|------|-------------|--------|-------------------|-------------|--------|--------|---|--|--|--|--|--|--|--|--|
| Year       | Code | Description | Amount | Code              | Description | Number | Amount | Comm Int  |  |  |  |  |  |  |  |  |
|            |      |             |        |                   |             |        |        |   |  |  |  |  |  |  |  |  |
| Total      |      |             | 0.00   |                   |             |        |        |   |  |  |  |  |  |  |  |  |

| ASSESSING NEIGHBORHOOD |           |   |         | NOTES |  |  |  | APPRAISED VALUE SUMMARY       |  |  |  |           |  |  |  |
|------------------------|-----------|---|---------|-------|--|--|--|-------------------------------|--|--|--|-----------|--|--|--|
| Nbhd                   | Nbhd Name | B | Tracing | Batch |  |  |  |                               |  |  |  |           |  |  |  |
| 0114                   |           |   | OSTVIL  |       |  |  |  |                               |  |  |  |           |  |  |  |
|                        |           |   |         |       |  |  |  | Appraised Bldg. Value (Card)  |  |  |  | 481,700   |  |  |  |
|                        |           |   |         |       |  |  |  | Appraised Xf (B) Value (Bldg) |  |  |  | 78,700    |  |  |  |
|                        |           |   |         |       |  |  |  | Appraised Ob (B) Value (Bldg) |  |  |  | 88,200    |  |  |  |
|                        |           |   |         |       |  |  |  | Appraised Land Value (Bldg)   |  |  |  | 527,900   |  |  |  |
|                        |           |   |         |       |  |  |  | Special Land Value            |  |  |  | 0         |  |  |  |
|                        |           |   |         |       |  |  |  | Total Appraised Parcel Value  |  |  |  | 1,176,500 |  |  |  |
|                        |           |   |         |       |  |  |  | Valuation Method              |  |  |  | C         |  |  |  |
|                        |           |   |         |       |  |  |  | Total Appraised Parcel Value  |  |  |  | 1,176,500 |  |  |  |

| BUILDING PERMIT RECORD |            |      |             |        |            |        |            |                     | VISIT / CHANGE HISTORY |    |      |    |    |                   |
|------------------------|------------|------|-------------|--------|------------|--------|------------|---------------------|------------------------|----|------|----|----|-------------------|
| Permit Id              | Issue Date | Type | Description | Amount | Insp Date  | % Comp | Date Comp  | Comments            | Date                   | Id | Type | Is | Cd | Purpost/Result    |
| 201506617              | 10-06-2015 | NR   | New Roof    | 8,000  | 06-30-2016 | 100    | 06-30-2016 | RE-ROOF AND RE-SIDE | 06-01-2020             | WD |      |    | FR | Field Review      |
| 56399                  | 10-11-2001 | NR   | New Roof    | 11,800 | 11-26-2001 | 100    | 01-01-2002 |                     | 09-09-2019             | CK | 22   |    | 22 | Change of Address |
|                        |            |      |             |        |            |        |            |                     | 05-23-2019             | SR | 02   |    | 03 | Cycl Insp Comp    |
|                        |            |      |             |        |            |        |            |                     | 05-12-2016             | JR | 03   |    | 20 | Sale Review       |
|                        |            |      |             |        |            |        |            |                     | 03-18-2015             | TR | 03   |    | 16 | In Office Review  |
|                        |            |      |             |        |            |        |            |                     | 08-27-2012             | TP | 03   |    | 16 | In Office Review  |
|                        |            |      |             |        |            |        |            |                     | 02-18-2011             | JR | 03   |    | 16 | In Office Review  |

| LAND LINE VALUATION SECTION |          |                |      |    |            |            |                        |         |            |       |       |           |                  |                    |            |            |         |
|-----------------------------|----------|----------------|------|----|------------|------------|------------------------|---------|------------|-------|-------|-----------|------------------|--------------------|------------|------------|---------|
| B                           | Use Code | Description    | Zone | LA | Land Units | Unit Price | Size Adj               | AC Disc | Site Index | Cond. | Nbhd. | Nbhd. Adj | Notes            | Location Adjustmen | Adj Unit P | Land Value |         |
| 1                           | 1010     | Single Fam M-0 | SPLI | 3  | 0.800      | AC         | 176,344.00             | 1.22679 | 1.0000     | 5     | 1.00  | 0111      | 3.050            |                    | 1.0000     | 659,826.3  | 527,900 |
| Total Card Land Units       |          |                |      |    | 0.80       | AC         | Parcel Total Land Area |         |            |       |       | 0.80      | Total Land Value |                    |            | 527,900    |         |

| CONSTRUCTION DETAIL |    |                | CONSTRUCTION DETAIL (CONTINUED) |      |             |
|---------------------|----|----------------|---------------------------------|------|-------------|
| Element             | Cd | Description    | Element                         | Cd   | Description |
| Style               | 01 | Ranch          |                                 |      |             |
| Model               | 01 | Residential    |                                 |      |             |
| Grade:              | C+ | Average Plus   |                                 |      |             |
| Stories             | 1  | 1 Story        |                                 |      |             |
| Exterior Wall 1     | 14 | Wood Shingle   |                                 |      |             |
| Exterior Wall 2     |    |                |                                 |      |             |
| RooF Structure      | 03 | Gable/Hip      |                                 |      |             |
| RooF Cover          | 03 | Asph/F Gls/Cmp |                                 |      |             |
| Interior Wall 1     | 05 | Drywall        |                                 |      |             |
| Interior Wall 2     |    |                |                                 |      |             |
| Interior Floor 1    | 12 | Hardwood       |                                 |      |             |
| Interior Floor 2    |    |                |                                 |      |             |
| Heat Fuel           | 03 | Gas            |                                 |      |             |
| Heat Type           | 04 | Hot Air        |                                 |      |             |
| AC Type             | 03 | Central        |                                 |      |             |
| Bedrooms            | 04 | 4 Bedrooms     |                                 |      |             |
| Full Baths          | 3  |                |                                 |      |             |
| Half Baths          | 0  |                |                                 |      |             |
| Extra Fixtures      |    |                |                                 |      |             |
| Total Rooms         | 7  | 7 Rooms        |                                 |      |             |
| Bath Style          |    |                |                                 |      |             |
| Kitchen Style       |    |                |                                 |      |             |
| Occupancy           |    |                |                                 |      |             |
| Usrflid 105         |    |                |                                 |      |             |
| Accessory Apt       |    |                |                                 |      |             |
| Foundation Alt      | 01 | Poured Conc.   |                                 |      |             |
| Rms Prts            |    |                |                                 |      |             |
| Bath Split          | 30 | 3 Full-0 Half  |                                 |      |             |
|                     |    |                | <b>CONDO DATA</b>               |      |             |
|                     |    |                | Parcel Id                       | C    | Ownr 0.0    |
|                     |    |                |                                 | B    | S           |
|                     |    |                | Adjust Type                     | Code | Description |
|                     |    |                | Condo Flr                       |      |             |
|                     |    |                | Condo Unit                      |      |             |
|                     |    |                | <b>COST / MARKET VALUATION</b>  |      |             |
|                     |    |                | Building Value New              |      | 633,867     |
|                     |    |                | Year Built                      |      | 1965        |
|                     |    |                | Effective Year Built            |      | 1988        |
|                     |    |                | Depreciation Code               |      | A           |
|                     |    |                | Remodel Rating                  |      |             |
|                     |    |                | Year Remodeled                  |      |             |
|                     |    |                | Depreciation %                  |      | 24          |
|                     |    |                | Functional Obsol                |      | 0           |
|                     |    |                | External Obsol                  |      | 0           |
|                     |    |                | Trend Factor                    |      | 1           |
|                     |    |                | Condition                       |      |             |
|                     |    |                | Condition %                     |      |             |
|                     |    |                | Percent Good                    |      | 76          |
|                     |    |                | RCNLD                           |      | 481,700     |
|                     |    |                | Dep % Ovr                       |      |             |
|                     |    |                | Dep Ovr Comment                 |      |             |
|                     |    |                | Misc Imp Ovr                    |      |             |
|                     |    |                | Misc Imp Ovr Comment            |      |             |
|                     |    |                | Cost to Cure Ovr                |      |             |
|                     |    |                | Cost to Cure Ovr Comment        |      |             |

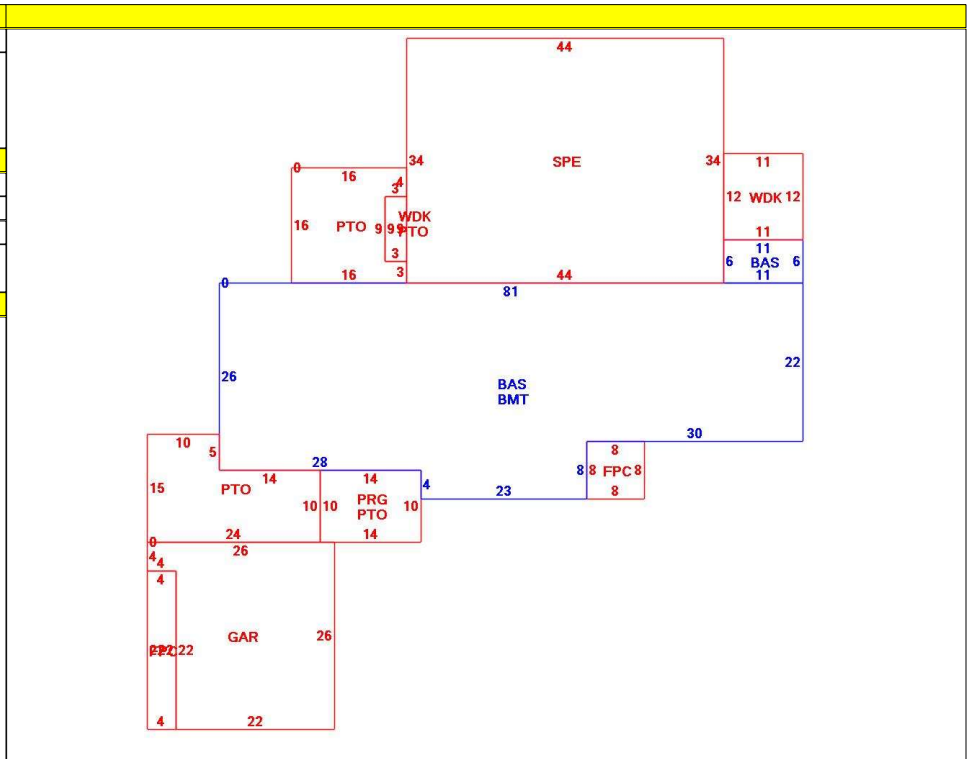

**OB - OUTBUILDING & YARD ITEMS(L) / XF - BUILDING EXTRA FEATURES(B)**

| Code | Description     | L/B | Units | Unit Price | Yr Blt | Cond. Cd | % Gd | Grade | Grade Adj. | Appr. Value |
|------|-----------------|-----|-------|------------|--------|----------|------|-------|------------|-------------|
| FPL1 | Fireplace 1 sto | B   | 1     | 5000.00    | 1990   |          | 76   |       | 0.00       | 3,800       |
| SPL7 | Indoor Pool     | L   | 576   | 70.00      | 1975   |          | 12   | 00    | 1.00       | 4,800       |
| BFA  | Bsmt Fin-Avg    | B   | 1,470 | 17.36      | 1990   |          | 76   |       | 0.00       | 19,400      |
| WDC  | Wood Decking    | L   | 159   | 20.00      | 2003   |          | 68   |       | 0.00       | 2,900       |
| PAT2 | Patio-Good      | L   | 686   | 9.94       | 2003   |          | 84   |       | 0.00       | 5,400       |
| FOPC | Open Prch-roo   | B   | 152   | 55.00      | 1990   |          | 76   |       | 0.00       | 4,700       |
| BMT  | Basement-Unfi   | B   | 2,078 | 26.01      | 1990   |          | 76   |       | 0.00       | 35,100      |
| SPLE | Swim Pool En    | L   | 1,496 | 86.62      | 1975   |          | 56   | C     | 1.00       | 72,600      |
| GAR  | Attached Gara   | B   | 588   | 40.00      | 1990   |          | 76   |       | 0.00       | 15,700      |
| PRG1 | Pergola-Avg     | L   | 140   | 18.00      | 2018   |          | 98   | C     | 1.00       | 2,500       |

**BUILDING SUB-AREA SUMMARY SECTION**

| Code                       | Description            | Living Area | Floor Area | Eff Area | Unit Cost | Undeprec Value |
|----------------------------|------------------------|-------------|------------|----------|-----------|----------------|
| BAS                        | First Floor            | 2,144       | 2,144      | 2,144    | 295.65    | 633,867        |
| BMT                        | Basement Area          | 0           | 2,078      | 0        | 0.00      | 0              |
| FPC                        | Open Porch Conc. Floor | 0           | 152        | 0        | 0.00      | 0              |
| GAR                        | Attached Garage        | 0           | 588        | 0        | 0.00      | 0              |
| PRG                        | Pergola                | 0           | 140        | 0        | 0.00      | 0              |
| PTO                        | Patio                  | 0           | 686        | 0        | 0.00      | 0              |
| SPE                        | Pool Enclosure         | 0           | 1,496      | 0        | 0.00      | 0              |
| WDK                        | Wood Deck              | 0           | 159        | 0        | 0.00      | 0              |
| Ttl Gross Liv / Lease Area |                        | 2,144       | 7,443      | 2,144    |           | 633,867        |

