

CURRENT OWNER		TOPO	UTILITIES	STRT / ROAD	LOCATION	CURRENT ASSESSMENT			
HANSEN, HEATHER J & BORINO, KRI  10936 ENDEAVOR DR  PARKER CO 80134		1 Level	2 Public Water	1 Paved		Description	Code	Assessed	Assessed
			4 Gas			RESIDNTL	1010	170,000	170,000
			6 Septic			RES LAND	1010	178,500	178,500
<b>SUPPLEMENTAL DATA</b>									
Alt Prcl ID			Split Zonin		Plan Ref. 94/47				
BID Parcel			ResExpt Q		Land Ct#				
#DL 1 LOT 146A			#DL 2		#SR				
GIS ID F_944502_2686288					Life Estate				
					PP STATU				
					Assoc Pid#				
						Total		348,500	348,500

801  
 FY2024  
 BARNSTABLE, MA

**VISION**

RECORD OF OWNERSHIP		BK-VOL/PAGE	SALE DATE	Q/U	V/I	SALE PRIC	VC	PREVIOUS ASSESSMENTS (HISTORY)					
HANSEN, HEATHER J & BORINO, KRISTI		34095 055	05-10-2021	Q	I	339,500	00	Year	Code	Assessed	Year	Code	Assessed
BISPLINGHOFF, ROSS L & RON S TRS		21340 0129	09-12-2006	U	I	0	1A	2023	1010	147,800	2022	1010	127,000
BISPLINGHOFF, ROSS L		6707 0159	04-21-1989	U	I	1	A		1010	176,400		1010	125,400
BISPLINGHOFF, RAYMOND L & ROSS L		3489 0141	05-28-1982	Q	I	47,000	U					1010	2,500
						Total		324,200	Total		252,400	Total	226,700

EXEMPTIONS			OTHER ASSESSMENTS					
Year	Code	Description	Amount	Code	Description	Number	Amount	Comm Int
			Total				0.00	

This signature acknowledges a visit by a Data Collector or Assessor

ASSESSING NEIGHBORHOOD			
Nbhd	Nbhd Name	B	Tracing
0106			COTUIT

NOTES	

APPRAISED VALUE SUMMARY	
Appraised Bldg. Value (Card)	163,500
Appraised Xf (B) Value (Bldg)	4,100
Appraised Ob (B) Value (Bldg)	2,400
Appraised Land Value (Bldg)	178,500
Special Land Value	0
Total Appraised Parcel Value	348,500
Valuation Method	C
Total Appraised Parcel Value	348,500

BUILDING PERMIT RECORD									VISIT / CHANGE HISTORY					
Permit Id	Issue Date	Type	Description	Amount	Insp Date	% Comp	Date Comp	Comments	Date	Id	Type	Is	Cd	Purpost/Result
B34139	01-01-1991	AD	Addition	15,000	01-15-1992	100	06-30-1992	CO REMOD'	10-11-2022	SR	01		03	Cycl Insp Comp
									06-10-2020	WD			FR	Field Review
									01-09-2014	DR	22		22	Change of Address
									02-28-2013	RB	03		03	Cycl Insp Comp
									03-13-2006	JK	22		22	Change of Address
									02-17-2005	PT	02		01	Meas/Est
									08-27-2002	PT	02		01	Meas/Est

LAND LINE VALUATION SECTION																		
B	Use Code	Description	Zone	LA	Land Units	Unit Price	Size Adj	AC Disc	Site Index	Cond.	Nbhd.	Nbhd. Adj	Notes	Location Adjustmen	Adj Unit P	Land Value		
1	1010	Single Fam M-0	RF	2	0.440 AC	176,344.00	2.00014	1.0000	5	1.00	0106	1.150	ABUTS GOLF COURSE		1.0000	405,626.4		
					Total Card Land Units	0.44 AC						Parcel Total Land Area	0.44				Total Land Value	178,500

CONSTRUCTION DETAIL			CONSTRUCTION DETAIL (CONTINUED)		
Element	Cd	Description	Element	Cd	Description
Style	01	Ranch			
Model	01	Residential			
Grade:	D+	Below Average			
Stories	1	1 Story			
Exterior Wall 1	14	Wood Shingle			
Exterior Wall 2					
RooF Structure	03	Gable/Hip			
RooF Cover	03	Asph/F Gls/Cmp			
Interior Wall 1	05	Drywall			
Interior Wall 2	02	Wall Brd/Wood			
Interior Floor 1	14	Carpet			
Interior Floor 2					
Heat Fuel	03	Gas			
Heat Type	04	Hot Air			
AC Type	01	None			
Bedrooms	02	2 Bedrooms			
Full Baths	1				
Half Baths	0				
Extra Fixtures					
Total Rooms	4	4 Rooms			
Bath Style					
Kitchen Style					
Occupancy					
Usrflid 105					
Accessory Apt					
Foundation Alt	09	Blk/Pour Ftgs			
Rms Prts					
Bath Split	10	1 Full-0 Half			

CONDO DATA			
Parcel Id		C	Owne 0.0
		B	S
Adjust Type	Code	Description	Factor%
Condo Flr			
Condo Unit			

COST / MARKET VALUATION		
Building Value New		233,585
Year Built		1950
Effective Year Built		1981
Depreciation Code		A
Remodel Rating		
Year Remodeled		
Depreciation %		30
Functional Obsol		0
External Obsol		0
Trend Factor		1
Condition		
Condition %		
Percent Good		70
RCNLD		163,500
Dep % Ovr		
Dep Ovr Comment		
Misc Imp Ovr		
Misc Imp Ovr Comment		
Cost to Cure Ovr		
Cost to Cure Ovr Comment		

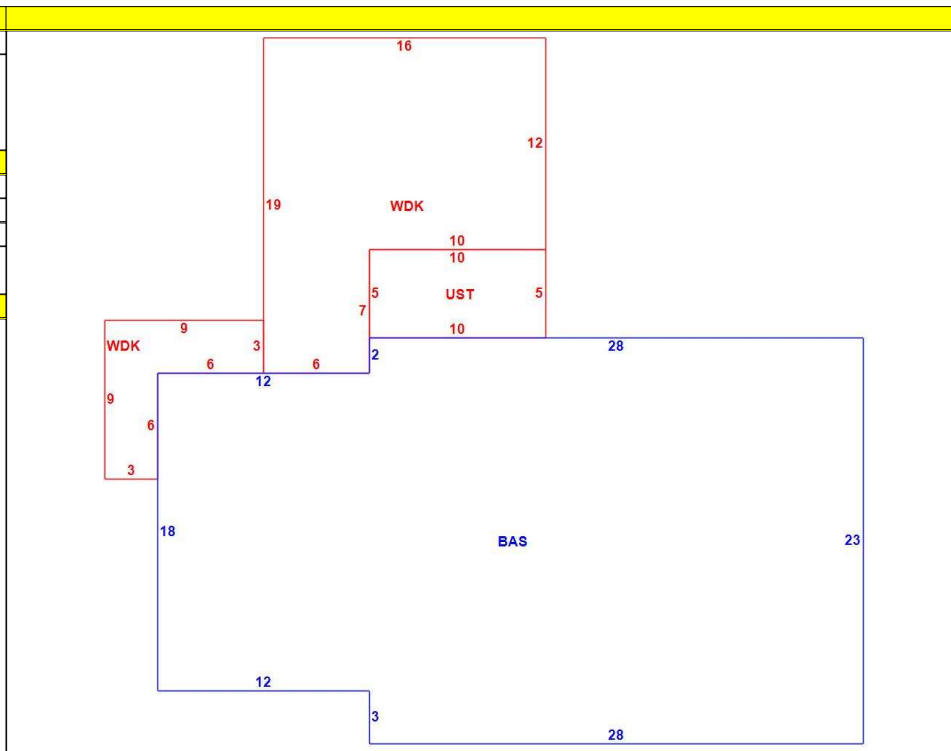

OB - OUTBUILDING & YARD ITEMS(L) / XF - BUILDING EXTRA FEATURES(B)										
Code	Description	L/B	Units	Unit Price	Yr Blt	Cond. Cd	% Gd	Grade	Grade Adj.	Appr. Value
FPL1	Fireplace 1 sto	B	1	5000.00	1983		70		0.00	3,500
WDC	Wood Decking	L	279	20.00	1990		42		0.00	2,400
UST	Utility Storage-	B	50	17.11	1983		70		0.00	600

BUILDING SUB-AREA SUMMARY SECTION							
Code	Description	Living Area	Floor Area	Eff Area	Unit Cost	Undeprec Value	
BAS	First Floor	860	860	860	271.61	233,585	
UST	Utility Enclosure	0	50	0	0.00	0	
WDK	Wood Deck	0	279	0	0.00	0	

Ttl Gross Liv / Lease Area		860	1,189	860		233,585
----------------------------	--	-----	-------	-----	--	---------

