

CURRENT OWNER		TOPO	UTILITIES	STRT / ROAD	LOCATION	CURRENT ASSESSMENT				801 FY2024 BARNSTABLE, MA VISION	
STANNEY, JONATHAN T & JESSICA 63 BAY STREET OSTERVILLE MA 02655		1 Level	6 Septic	1 Paved		Description	Code	Assessed	Assessed		
			4 Gas			RESIDNTL	1010	799,100	799,100		
			2 Public Water			RES LAND	1010	1,028,700	1,028,700		
SUPPLEMENTAL DATA						Total				1,827,800	1,827,800
Alt Prcl ID		Split Zonin		Plan Ref.							
BID Parcel		ResExpt Q		Land Ct# 25910-B & 14421-#SR							
#DL 1 LOTS 4, 5 & 6		#DL 2		Life Estate							
GIS ID F_959715_2691492				PP STATU							
				Assoc Pid#							

RECORD OF OWNERSHIP		BK-VOL/PAGE	SALE DATE	Q/U	V/I	SALE PRIC	VC	PREVIOUS ASSESSMENTS (HISTORY)						
STANNEY, JONATHAN T & JESSICA M		C219264	0	04-30-2019	Q	I	1,050,000	00	Year	Code	Assessed	Year	Code	Assessed
BELL, JAMES D & HELEN R TRS		C196516	0	03-06-2012	U	I	1	1F	2023	1010	718,100	2022	1010	616,100
BELL, JAMES D		C195520	0	10-28-2011	Q	I	1,000,000	00		1010	855,000		1010	569,500
FARLEY, AUDREY C		C179109	0	01-26-2006	U	I	1,900,000	1A					1010	70,400
FARLEY, AUDREY CHURCHILL TR		C140403	0	04-15-1996	U	I	1	A	Total		1,573,100	Total		1,185,600
										Total		Total		1,054,100

EXEMPTIONS			OTHER ASSESSMENTS				This signature acknowledges a visit by a Data Collector or Assessor					
Year	Code	Description	Amount	Code	Description	Number	Amount	Comm Int				
Total			0.00									

ASSESSING NEIGHBORHOOD				APPRAISED VALUE SUMMARY			
Nbhd	Nbhd Name	B	Tracing	Batch			
0114				OSTVIL	Appraised Bldg. Value (Card)	640,400	
					Appraised Xf (B) Value (Bldg)	88,300	
					Appraised Ob (B) Value (Bldg)	70,400	
					Appraised Land Value (Bldg)	1,028,700	
					Special Land Value	0	
					Total Appraised Parcel Value	1,827,800	
					Valuation Method	C	
					Total Appraised Parcel Value	1,827,800	

NOTES										VISIT / CHANGE HISTORY					
Permit Id	Issue Date	Type	Description	Amount	Insp Date	% Comp	Date Comp	Comments	Date	Id	Type	Is	Cd	Purpost/Result	
201401105	02-26-2014	SP	Swimming Pool	29,654	07-15-2014	100	06-30-2014	HEATED POOL 16X32 W SPA	06-01-2020	WD			FR	Field Review	
201308212	11-07-2013	GN	Generator	0	04-10-2014	100	06-30-2014	GEN	02-20-2020	SAF			20	Sale Review	
201201794	04-03-2012	OT	Other	31,864	04-10-2014	100	06-30-2014	INSTALL GOLDEN FLUE CAS	01-16-2020	CK	03		16	In Office Review	
201200403	02-10-2012	RE	Remodel	50,000	04-10-2014	100	06-30-2014	REMOD 2 TBHS & KIT	07-17-2019	CK	22		22	Change of Address	
20061246	06-20-2006	RW	Repair Work	30,000	07-09-2007	100	06-30-2007		07-26-2016	JR	03		16	In Office Review	
B31103	08-01-1987	AD	Addition	30,000	01-15-1989	100	06-30-1989	OS ADD'N	07-22-2014	MW	01		02	Bldg Permit Completed	
B27346	12-01-1984	AD	Addition	15,000	02-15-1986	100	06-30-1986	OS	05-15-2014	MW	01		13	CALL BACK	

LAND LINE VALUATION SECTION																	
B	Use Code	Description	Zone	LA	Land Units	Unit Price	Size Adj	AC Disc	Site Index	Cond.	Nbhd.	Nbhd. Adj	Notes	Location Adjustmen	Adj Unit P	Land Value	
1	1010	Single Fam M-0	RC	3	1.000	AC 176,344.00	1.00000	1.0000	5	1.00	0112	5.500	GOLF COURSE FRONT		1.0000	969,892	
1	1010	Single Fam M-0	RC	3	0.750	AC 14,250.00	1.00000	1.0000	0	1.00	0112	5.500	ABUTS GC		1.0000	58,800	
Total Card Land Units					1.75	AC	Parcel Total Land Area					1.75	Total Land Value				1,028,700

CONSTRUCTION DETAIL			CONSTRUCTION DETAIL (CONTINUED)		
Element	Cd	Description	Element	Cd	Description
Style	04	Cape Cod			
Model	01	Residential			
Grade:	B-	Custom Minus			
Stories	1.5	1 1/2 Stories			
Exterior Wall 1	14	Wood Shingle			
Exterior Wall 2	08	Wood on Sheath			
Roof Structure	03	Gable/Hip			
Roof Cover	10	Wood Shingle			
Interior Wall 1	03	Plastered			
Interior Wall 2	05	Drywall			
Interior Floor 1	09	Pine/Soft Wood			
Interior Floor 2	15	Quarry Tile			
Heat Fuel	03	Gas			
Heat Type	04	Hot Air			
AC Type	03	Central			
Bedrooms	04	4 Bedrooms			
Full Baths	3				
Half Baths	0				
Extra Fixtures					
Total Rooms	10	10 Rooms			
Bath Style					
Kitchen Style					
Occupancy					
Usrflid 105					
Accessory Apt					
Foundation Alt	05	Stone Walls			
Rms Prts					
Bath Split	30	3 Full-0 Half			
			CONDO DATA		
			Parcel Id		C
			Owne 0.0		
			Adjust Type	Code	Description
			Condo Flr		
			Condo Unit		
			COST / MARKET VALUATION		
			Building Value New		877,297
			Year Built		1765
			Effective Year Built		1984
			Depreciation Code		G
			Remodel Rating		
			Year Remodeled		
			Depreciation %		27
			Functional Obsol		0
			External Obsol		0
			Trend Factor		1
			Condition		
			Condition %		
			Percent Good		73
			RCNLD		640,400
			Dep % Ovr		
			Dep Ovr Comment		
			Misc Imp Ovr		
			Misc Imp Ovr Comment		
			Cost to Cure Ovr		
			Cost to Cure Ovr Comment		

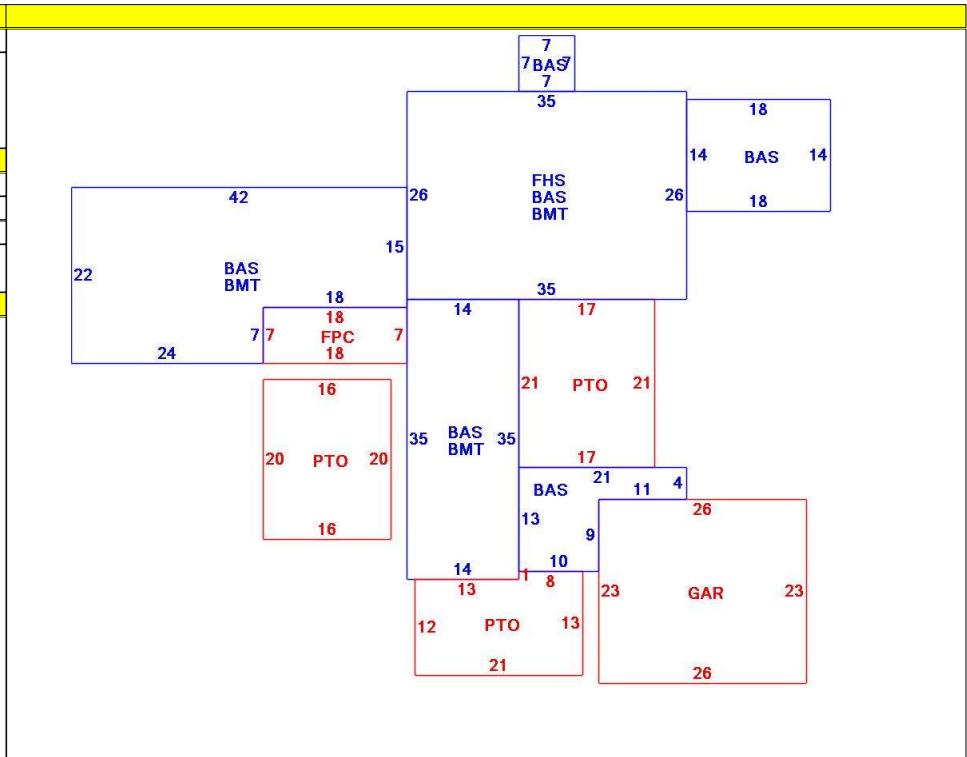

OB - OUTBUILDING & YARD ITEMS(L) / XF - BUILDING EXTRA FEATURES(B)										
Code	Description	L/B	Units	Unit Price	Yr Blt	Cond. Cd	% Gd	Grade	Grade Adj.	Appr. Value
FPL2	Fireplace 1.5 s	B	1	6000.00	1984		73		0.00	4,400
FPO	Ext FP Openin	B	2	2000.00	1984		73		0.00	2,900
SHD2	Shed w/Elec	L	240	26.00	1990		42		0.00	2,600
BFA1	Bsmt Fin-Goo	B	900	32.56	1984		73		0.00	21,400
PAT1	Patio- Average	L	260	5.89	1986		67		0.00	1,100
FOPC	Open Prch-roo	B	126	55.00	1984		100		0.00	5,400
GAR	Attached Gara	B	598	40.00	1984		73		0.00	15,300
BMT	Basement-Unfi	B	2,198	26.01	1984		73		0.00	35,200
PATF	Flagstone Pav	L	677	30.00	1987		68		0.00	13,000
FPL1	Fireplace 1 sto	B	1	5000.00	1984		73		0.00	3,700

BUILDING SUB-AREA SUMMARY SECTION						
Code	Description	Living Area	Floor Area	Eff Area	Unit Cost	Undeprec Value
BAS	First Floor	2,673	2,673	2,673	280.47	749,685
BMT	Basement Area	0	2,198	0	0.00	0
FHS	Half Story	455	910	455	140.23	127,612
FPC	Open Porch Conc. Floor	0	126	0	0.00	0
GAR	Attached Garage	0	598	0	0.00	0
PTO	Patio	0	937	0	0.00	0
Ttl Gross Liv / Lease Area		3,128	7,442	3,128		877,297



CURRENT OWNER		TOPO	UTILITIES	STRT / ROAD	LOCATION	CURRENT ASSESSMENT				801 FY2024 BARNSTABLE, MA
STANNEY, JONATHAN T & JESSICA 63 BAY STREET OSTERVILLE MA 02655		1 Level	6 Septic	1 Paved		Description	Code	Assessed	Assessed	
			4 Gas			RESIDNTL	1010	799,100	799,100	
			2 Public Water			RES LAND	1010	1,028,700	1,028,700	
SUPPLEMENTAL DATA										VISION
Alt Prcl ID			Plan Ref.							
Split Zonin			Land Ct# 25910-B & 14421-							
BID Parcel			#SR							
ResExpt Q			Life Estate							
#DL 1 LOTS 4, 5 & 6			PP STATU							
#DL 2										
GIS ID F_959715_2691492			Assoc Pid#							
						Total		1,827,800	1,827,800	

RECORD OF OWNERSHIP		BK-VOL/PAGE	SALE DATE	Q/U	V/I	SALE PRIC	VC	PREVIOUS ASSESSMENTS (HISTORY)					
								Year	Code	Assessed	Year	Code	Assessed
								2023	1010	718,100	2022	1010	616,100
									1010	855,000		1010	569,500
											2021	1010	465,900
												1010	517,800
												1010	70,400
								Total		1,573,100	Total		1,185,600
								Total			Total		1,054,100

EXEMPTIONS			OTHER ASSESSMENTS					This signature acknowledges a visit by a Data Collector or Assessor				
Year	Code	Description	Amount	Code	Description	Number	Amount	Comm Int				
Total												

ASSESSING NEIGHBORHOOD				APPRAISED VALUE SUMMARY			
Nbhd	Nbhd Name	B	Tracing	Batch			
0114				OSTVIL	Appraised Bldg. Value (Card)	640,400	
					Appraised Xf (B) Value (Bldg)	88,300	
					Appraised Ob (B) Value (Bldg)	70,400	
					Appraised Land Value (Bldg)	1,028,700	
					Special Land Value	0	
					Total Appraised Parcel Value	1,827,800	
					Valuation Method	C	
					Total Appraised Parcel Value	1,827,800	

NOTES										VISIT / CHANGE HISTORY					
										Date	Id	Type	Is	Cd	Purpost/Result

BUILDING PERMIT RECORD										VISIT / CHANGE HISTORY					
Permit Id	Issue Date	Type	Description	Amount	Insp Date	% Comp	Date Comp	Comments		Date	Id	Type	Is	Cd	Purpost/Result

LAND LINE VALUATION SECTION																
B	Use Code	Description	Zone	LA	Land Units	Unit Price	Size Adj	AC Disc	Site Index	Cond.	Nbhd.	Nbhd. Adj	Notes	Location Adjustmen	Adj Unit P	Land Value
Total Card Land Units					Parcel Total Land Area					Total Land Value						

