

| CURRENT OWNER | | TOPO | UTILITIES | STRT / ROAD | LOCATION | CURRENT ASSESSMENT | | | |
|---|--|--------------------------|-------------------|-------------------|----------|--------------------|------|-----------|-----------|
| CAMP, CHRISTIAN R 4 ANTLER PINE RD | | 1 Level | 6 Septic | 1 Paved | | Description | Code | Assessed | Assessed |
| | | | 4 Gas | | | RESIDNTL | 1010 | 708,800 | 708,800 |
| SANDY HOOK CT 06482-1008 | | | 2 Public Water | | | RES LAND | 1010 | 514,000 | 514,000 |
| | | SUPPLEMENTAL DATA | | | | Total | | 1,222,800 | 1,222,800 |
| | | Alt Prcl ID | Split Zonin RC;BA | Plan Ref. 531/93 | | VISION | | | |
| | | BID Parcel | | Land Ct# | | | | | |
| | | ResExpt Q | | #SR | | | | | |
| | | #DL 1 LOT 9-1 | | Life Estate | | | | | |
| | | #DL 2 | | PP STATU A:Active | | | | | |
| | | GIS ID F_959657_2693278 | | Assoc Pid# | | | | | |

| RECORD OF OWNERSHIP | | BK-VOL/PAGE | SALE DATE | Q/U | V/I | SALE PRIC | VC | PREVIOUS ASSESSMENTS (HISTORY) | | | | | |
|--------------------------------|-------|-------------|------------|-----|-----|-----------|----|--------------------------------|------|----------|-------|------|----------|
| CAMP, CHRISTIAN R | 34400 | 145 | 08-20-2021 | Q | I | 1,100,000 | 00 | Year | Code | Assessed | Year | Code | Assessed |
| DECEMBRELE, RICHARD A & NORA M | 29256 | 0135 | 11-06-2015 | Q | I | 634,000 | 00 | 2023 | 1010 | 608,900 | 2022 | 1010 | 506,200 |
| HOAGLAND, JOHN III & ROBIN E | 19697 | 0188 | 04-06-2005 | Q | I | 602,000 | 00 | | 1010 | 361,700 | | 1010 | 307,000 |
| BUTLER, JOHN M & KAREN E | 9646 | 0232 | 04-15-1995 | U | I | 1 | A | Total | | 970,600 | Total | | 813,200 |
| | | | | | | | | Total | | 705,800 | Total | | 705,800 |

| EXEMPTIONS | | | OTHER ASSESSMENTS | | | | | |
|------------|------|-------------|-------------------|------|-------------|--------|--------|----------|
| Year | Code | Description | Amount | Code | Description | Number | Amount | Comm Int |
| | | Total | 0.00 | | | | | |

| ASSESSING NEIGHBORHOOD | | | |
|------------------------|-----------|---|---------|
| Nbhd | Nbhd Name | B | Tracing |
| 0110 | | | OSTVIL |

| NOTES | | | |
|-------|--|--|--|
| | | | |

| BUILDING PERMIT RECORD | | | | | | | | VISIT / CHANGE HISTORY | | | | | | |
|------------------------|------------|------|------------------|--------|------------|--------|------------|---------------------------------|------------|----|------|----|----|-----------------------|
| Permit Id | Issue Date | Type | Description | Amount | Insp Date | % Comp | Date Comp | Comments | Date | Id | Type | Is | Cd | Purpost/Result |
| BLDR-23-32 | 04-20-2023 | 880 | Alt-Int work-Res | 30,000 | | 100 | | Demo and Remodel two bathr | 08-01-2022 | BM | 22 | | 22 | Change of Address |
| 18-766 | 04-09-2018 | 880 | Alt-Int work-Res | 10,000 | 06-30-2019 | 100 | 06-30-2019 | install new bathroom in garage | 02-09-2022 | BM | 03 | | 16 | In Office Review |
| 17-2947 | 09-05-2017 | 822 | Insulation | 0 | 06-01-2018 | 100 | 06-30-2018 | install 10" layer R37 Class 1 c | 11-12-2021 | BM | 22 | | 22 | Change of Address |
| 201101610 | 09-21-2011 | DG | Detached Gara | 45,000 | 01-19-2012 | 100 | 06-30-2012 | 20x24 DET GAR | 06-01-2020 | WD | | | FR | Field Review |
| 90704 | 03-07-2006 | RE | Remodel | 9,800 | 09-15-2006 | 100 | 06-30-2007 | BATH | 06-30-2019 | TR | 03 | | 16 | In Office Review |
| 84871 | 06-22-2005 | NS | New Siding | 4,500 | 06-30-2005 | 100 | 06-30-2005 | | 06-01-2018 | MS | 03 | | 02 | Bldg Permit Completed |
| | | | | | | | | | 08-16-2017 | MS | 02 | | 14 | Cyclical Inspection |

| LAND LINE VALUATION SECTION | | | | | | | | | | | | | | | | | |
|-----------------------------|----------|----------------|------|----|------------|------------------------|----------|---------|------------|-------|-------|------------------|-------|--------------------|------------|------------|---------|
| B | Use Code | Description | Zone | LA | Land Units | Unit Price | Size Adj | AC Disc | Site Index | Cond. | Nbhd. | Nbhd. Adj | Notes | Location Adjustmen | Adj Unit P | Land Value | |
| 1 | 1010 | Single Fam M-0 | SPLI | 3 | 0.610 AC | 176,344.00 | 1.54133 | 1.0000 | 5 | 1.00 | 0110 | 3.100 | | 1.0000 | 842,589.2 | 514,000 | |
| Total Card Land Units | | | | | 0.61 AC | Parcel Total Land Area | | | | | 0.61 | Total Land Value | | | | | 514,000 |

| CONSTRUCTION DETAIL | | | CONSTRUCTION DETAIL (CONTINUED) | | |
|--------------------------------|----|----------------|---------------------------------|---------|-------------|
| Element | Cd | Description | Element | Cd | Description |
| Style | 06 | Conventional | | | |
| Model | 01 | Residential | | | |
| Grade: | B | Custom | | | |
| Stories | 2 | 2 Stories | | | |
| Exterior Wall 1 | 14 | Wood Shingle | | | |
| Exterior Wall 2 | | | | | |
| RooF Structure | 03 | Gable/Hip | | | |
| RooF Cover | 10 | Wood Shingle | | | |
| Interior Wall 1 | 03 | Plastered | | | |
| Interior Wall 2 | | | | | |
| Interior Floor 1 | 09 | Pine/Soft Wood | | | |
| Interior Floor 2 | 14 | Carpet | | | |
| Heat Fuel | 03 | Gas | | | |
| Heat Type | 05 | Hot Water | | | |
| AC Type | 01 | None | | | |
| Bedrooms | 04 | 4 Bedrooms | | | |
| Full Baths | 2 | | | | |
| Half Baths | 1 | | | | |
| Extra Fixtures | | | | | |
| Total Rooms | 7 | 7 Rooms | | | |
| Bath Style | | | | | |
| Kitchen Style | | | | | |
| Occupancy | | | | | |
| Usrflid 105 | | | | | |
| Accessory Apt | | | | | |
| Foundation Alt | 11 | Stone Ftgs | | | |
| Rms Prts | | | | | |
| Bath Split | 21 | 2 Full-1 Half | | | |
| CONDO DATA | | | | | |
| Parcel Id | | C | Owne | | 0.0 |
| Adjust Type | | Code | Description | | Factor% |
| Condo Flr | | | Condo Unit | | |
| COST / MARKET VALUATION | | | | | |
| Building Value New | | | | 735,232 | |
| Year Built | | | | 1920 | |
| Effective Year Built | | | | 1999 | |
| Depreciation Code | | | | E | |
| Remodel Rating | | | | | |
| Year Remodeled | | | | | |
| Depreciation % | | | | 16 | |
| Functional Obsol | | | | 0 | |
| External Obsol | | | | 0 | |
| Trend Factor | | | | 1 | |
| Condition | | | | | |
| Condition % | | | | | |
| Percent Good | | | | 84 | |
| RCNLD | | | | 617,600 | |
| Dep % Ovr | | | | | |
| Dep Ovr Comment | | | | | |
| Misc Imp Ovr | | | | | |
| Misc Imp Ovr Comment | | | | | |
| Cost to Cure Ovr | | | | | |
| Cost to Cure Ovr Comment | | | | | |

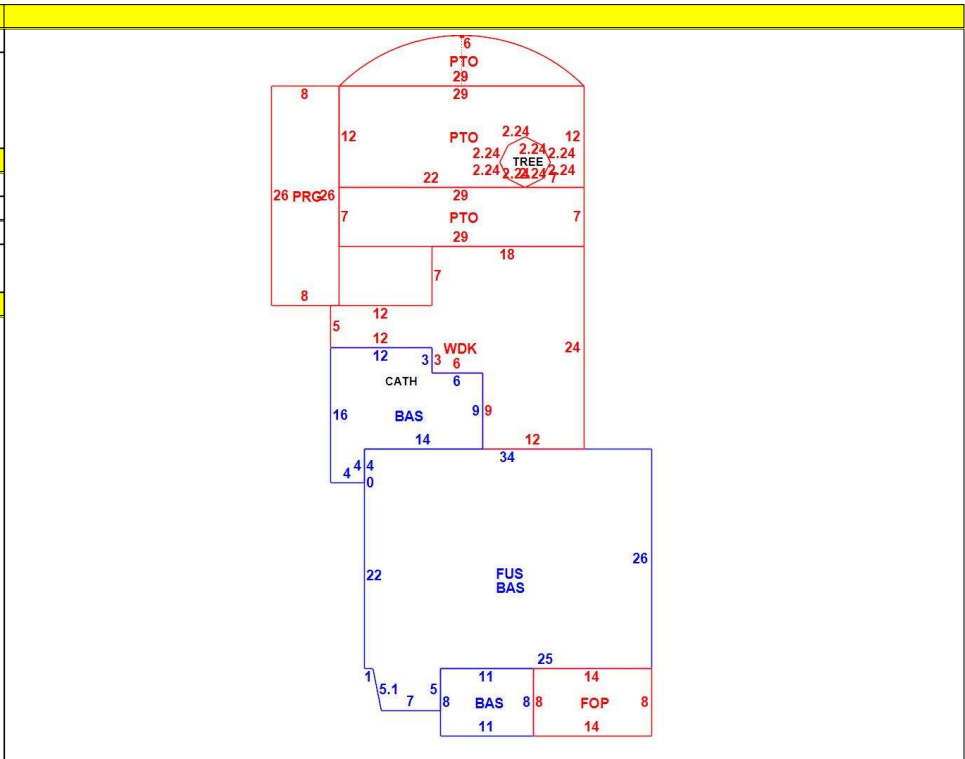

| OB - OUTBUILDING & YARD ITEMS(L) / XF - BUILDING EXTRA FEATURES(B) | | | | | | | | | | |
|--|-----------------|-----|-------|------------|--------|----------|------|-------|------------|-------------|
| Code | Description | L/B | Units | Unit Price | Yr Blt | Cond. Cd | % Gd | Grade | Grade Adj. | Appr. Value |
| FPL2 | Fireplace 1.5 s | B | 2 | 6000.00 | 1999 | | 84 | | 0.00 | 10,100 |
| WDC | Wood Decking | L | 438 | 20.00 | 1986 | | 34 | | 0.00 | 2,800 |
| FOP | Open Porch-ro | B | 112 | 55.00 | 1999 | | 84 | | 0.00 | 5,000 |
| GAR3 | Det Gar-w/TQ | L | 576 | 100.00 | 2011 | | 92 | C+ | 1.10 | 58,300 |
| SHED | Shed | L | 220 | 18.00 | 1986 | | 34 | | 0.00 | 1,300 |
| PATF | Flagstone Pav | L | 647 | 30.00 | 1986 | | 67 | | 0.00 | 12,300 |
| PRG1 | Pergola-Avg | L | 208 | 18.00 | 1986 | | 34 | C+ | 1.10 | 1,400 |

| BUILDING SUB-AREA SUMMARY SECTION | | | | | | |
|-----------------------------------|-------------|-------------|------------|----------|-----------|----------------|
| Code | Description | Living Area | Floor Area | Eff Area | Unit Cost | Undeprec Value |
| BAS | First Floor | 1,224 | 1,224 | 1,224 | 342.61 | 419,350 |
| FOP | Open Porch | 0 | 112 | 0 | 0.00 | 0 |
| FUS | Upper Story | 922 | 922 | 922 | 342.61 | 315,883 |
| PRG | Pergola | 0 | 208 | 0 | 0.00 | 0 |
| PTO | Patio | 0 | 647 | 0 | 0.00 | 0 |
| WDK | Wood Deck | 0 | 438 | 0 | 0.00 | 0 |
| Ttl Gross Liv / Lease Area | | 2,146 | 3,551 | 2,146 | | 735,233 |

