

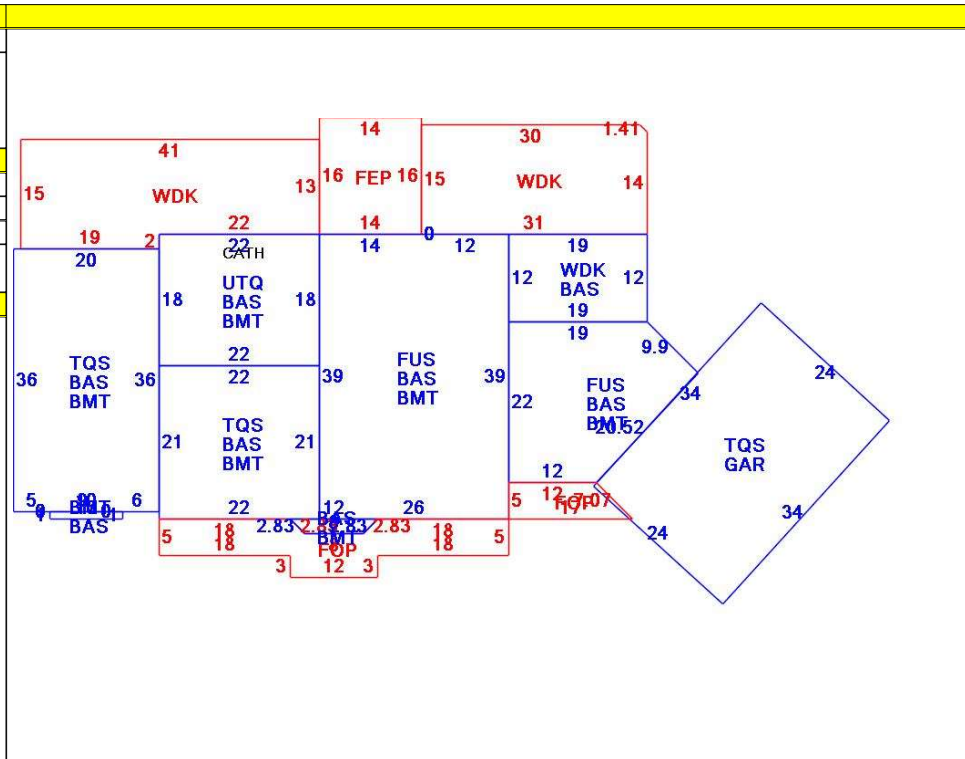

CONSTRUCTION DETAIL			CONSTRUCTION DETAIL (CONTINUED)		
Element	Cd	Description	Element	Cd	Description
Style	04	Cape Cod			
Model	01	Residential			
Grade:	A	Luxury			
Stories	2	2 Stories			
Exterior Wall 1	14	Wood Shingle			
Exterior Wall 2					
RooF Structure	03	Gable/Hip			
RooF Cover	03	Asph/F Gls/Cmp			
Interior Wall 1	03	Plastered			
Interior Wall 2					
Interior Floor 1	12	Hardwood			
Interior Floor 2					
Heat Fuel	03	Gas			
Heat Type	04	Hot Air			
AC Type	03	Central			
Bedrooms	05	5 Bedrooms			
Full Baths	6				
Half Baths	1				
Extra Fixtures					
Total Rooms	10				
Bath Style					
Kitchen Style					
Occupancy					
Usrflid 105					
Accessory Apt					
Foundation Alt	01	Poured Conc.			
Rms Prts					
Bath Split	51	5 Full-1 Half			

CONDO DATA			
Parcel Id	C	Ownr	0.0
Adjust Type	Code	Description	Factor%
Condo Flr			
Condo Unit			
COST / MARKET VALUATION			
Building Value New		2,302,557	
Year Built		2005	
Effective Year Built		2008	
Depreciation Code		A	
Remodel Rating			
Year Remodeled			
Depreciation %		9	
Functional Obsol		0	
External Obsol		0	
Trend Factor		1	
Condition			
Condition %			
Percent Good		91	
RCNLD		2,095,300	
Dep % Ovr			
Dep Ovr Comment			
Misc Imp Ovr			
Misc Imp Ovr Comment			
Cost to Cure Ovr			
Cost to Cure Ovr Comment			



OB - OUTBUILDING & YARD ITEMS(L) / XF - BUILDING EXTRA FEATURES(B)										
Code	Description	L/B	Units	Unit Price	Yr Blt	Cond. Cd	% Gd	Grade	Grade Adj.	Appr. Value
SPL3	Pool Gunite	L	612	75.00	2005		72	00	1.00	35,100
FPL2	Fireplace 1.5 s	B	2	6000.00	2010		91		0.00	10,900
FOP	Open Porch-ro	B	328	55.00	2010		91		0.00	11,700
GAR	Attached Gara	B	816	40.00	2010		91		0.00	24,000
BMT	Basement-Unfi	B	3,064	26.01	2010		91		0.00	58,000
SPH2	Pool Heater 50	L	1	3081.00	2006		74		0.00	2,300
WDC	Wood Deck w/	L	1,263	18.00	2012		86		0.00	17,300
PATC	Conc Pavers	L	768	15.46	2012		93		0.00	10,300
FEP	Enclosed porc	B	224	70.00	2010		91		0.00	12,300
BFA3	Bsmt Fin-Exc-	B	1,782	63.36	2010		91		0.00	102,700

BUILDING SUB-AREA SUMMARY SECTION						
Code	Description	Living Area	Floor Area	Eff Area	Unit Cost	Undeprec Value
BAS	First Floor	3,293	3,293	3,293	368.59	1,213,754
BMT	Basement Area	0	3,065	0	0.00	0
FEP	Enclosed Porch	0	224	0	0.00	0
FOP	Open Porch	0	329	0	0.00	0
FUS	Upper Story	1,457	1,457	1,457	368.59	537,030
GAR	Attached Garage	0	816	0	0.00	0
TQS	Three Quarter Story	1,299	1,998	1,299	239.64	478,793
UTQ	Unfinished Three-quarter story	0	396	198	184.29	72,980
WDK	Wood Deck	0	1,264	0	0.00	0
Ttl Gross Liv / Lease Area		6,049	12,842	6,247		2,302,557

