

CURRENT OWNER		TOPO	UTILITIES	STRT / ROAD	LOCATION	CURRENT ASSESSMENT					
MEYER, LINDA & SALVA, RAYMOND		2 Above Street	2 Public Water	1 Paved		Description	Code	Assessed	Assessed		
116 OLDHAM ROAD			6 Septic			RESIDNTL	1010	337,800	337,800		
OSTERVILLE MA 02655			4 Gas			RES LAND	1010	152,200	152,200		
SUPPLEMENTAL DATA											
Alt Prcl ID					Plan Ref. 262/58						
Split Zonin					Land Ct#						
BID Parcel					#SR						
ResExpt Q YES:					Life Estate						
#DL 1 LOT 41					PP STATU						
#DL 2					Assoc Pid#						
GIS ID F_960964_2698163					Total					490,000	490,000

801
 FY2024
 BARNSTABLE, MA
VISION

RECORD OF OWNERSHIP		BK-VOL/PAGE	SALE DATE	Q/U	V/I	SALE PRIC	VC	PREVIOUS ASSESSMENTS (HISTORY)							
MEYER, LINDA & SALVA, RAYMOND		33399 0322	10-26-2020	Q	I	401,000	00	Year	Code	Assessed	Year	Code	Assessed		
BERNARDO, JUSTIN & PAMELA		21650 0076	12-27-2006	U	I	100	1A	2023	1010	288,400	2022	1010	243,300		
BERNARDO, JUSTIN K		16841 0316	05-01-2003	Q	I	239,350	00		1010	138,400	2021	1010	102,500		
CABRAL, ERIN J K & ERIC M		15146 0277	05-10-2002	U	I	1	1A					1010	5,600		
KENNEDY, ERIN J		11535 0174	06-29-1998	Q	I	96,500	00	Total		426,800	Total		345,800	Total	294,500

EXEMPTIONS			OTHER ASSESSMENTS					
Year	Code	Description	Amount	Code	Description	Number	Amount	Comm Int
2022	5C	RESIDENTIAL EXEMPTION	0.00					
Total			0.00					

This signature acknowledges a visit by a Data Collector or Assessor

ASSESSING NEIGHBORHOOD			
Nbhd	Nbhd Name	B	Tracing
0105			OSTVIL

APPRAISED VALUE SUMMARY	
Appraised Bldg. Value (Card)	332,200
Appraised Xf (B) Value (Bldg)	0
Appraised Ob (B) Value (Bldg)	5,600
Appraised Land Value (Bldg)	152,200
Special Land Value	0
Total Appraised Parcel Value	490,000
Valuation Method	C
Total Appraised Parcel Value	490,000

NOTES							

BUILDING PERMIT RECORD								VISIT / CHANGE HISTORY							
Permit Id	Issue Date	Type	Description	Amount	Insp Date	% Comp	Date Comp	Comments	Date	Id	Type	Is	Cd	Purpost/Result	
200700112	01-24-2007	AD	Addition	77,600	10-31-2007	100	06-30-2007	OS DWELL	09-02-2021	LH	03		16	In Office Review	
B22069	03-01-1980	DW	Dwelling	0	01-15-1981	100			02-03-2021	CK	22		22	Change of Address	
									02-02-2021	CK	22		22	Change of Address	
									05-26-2020	WD				FR	Field Review
									12-05-2017	KM	06		03	Cycl Insp Comp	
									10-31-2007	PT	02		14	Cyclical Inspection	
									12-15-2006	PT	02		14	Cyclical Inspection	

LAND LINE VALUATION SECTION																
B	Use Code	Description	Zone	LA	Land Units	Unit Price	Size Adj	AC Disc	Site Index	Cond.	Nbhd.	Nbhd. Adj	Notes	Location Adjustmen	Adj Unit P	Land Value
1	1010	Single Fam M-0	RC	3	0.350 AC	176,344.00	2.46674	1.0000	5	1.00	0105	1.000		1.0000	434,987.7	152,200
Total Card Land Units					0.35	AC	Parcel Total Land Area					0.35	Total Land Value			152,200

CONSTRUCTION DETAIL			CONSTRUCTION DETAIL (CONTINUED)		
Element	Cd	Description	Element	Cd	Description
Style	01	Ranch			
Model	01	Residential			
Grade:	C	Average			
Stories	1	1 Story			
Exterior Wall 1	06	Vertical Sidin			
Exterior Wall 2	11	Clapboard			
Roof Structure	03	Gable/Hip			
Roof Cover	03	Asph/F Gls/Cmp			
Interior Wall 1	05	Drywall			
Interior Wall 2					
Interior Floor 1	14	Carpet			
Interior Floor 2					
Heat Fuel	03	Gas			
Heat Type	04	Hot Air			
AC Type	01	None			
Bedrooms	02	2 Bedrooms			
Full Baths	1				
Half Baths	0				
Extra Fixtures					
Total Rooms	6	5 Rooms			
Bath Style					
Kitchen Style					
Occupancy					
Usrflid 105					
Accessory Apt					
Foundation Alt	01	Poured Conc.			
Rms Prts					
Bath Split	10	1 Full-0 Half			

CONDO DATA				
Parcel Id		C	Ownr	0.0
Adjust Type	Code	Description	Factor%	
Condo Flr				
Condo Unit				

COST / MARKET VALUATION		
Building Value New		405,182
Year Built		1981
Effective Year Built		1996
Depreciation Code		A
Remodel Rating		
Year Remodeled		
Depreciation %		18
Functional Obsol		0
External Obsol		0
Trend Factor		1
Condition		
Condition %		
Percent Good		82
RCNLD		332,200
Dep % Ovr		
Dep Ovr Comment		
Misc Imp Ovr		
Misc Imp Ovr Comment		
Cost to Cure Ovr		
Cost to Cure Ovr Comment		

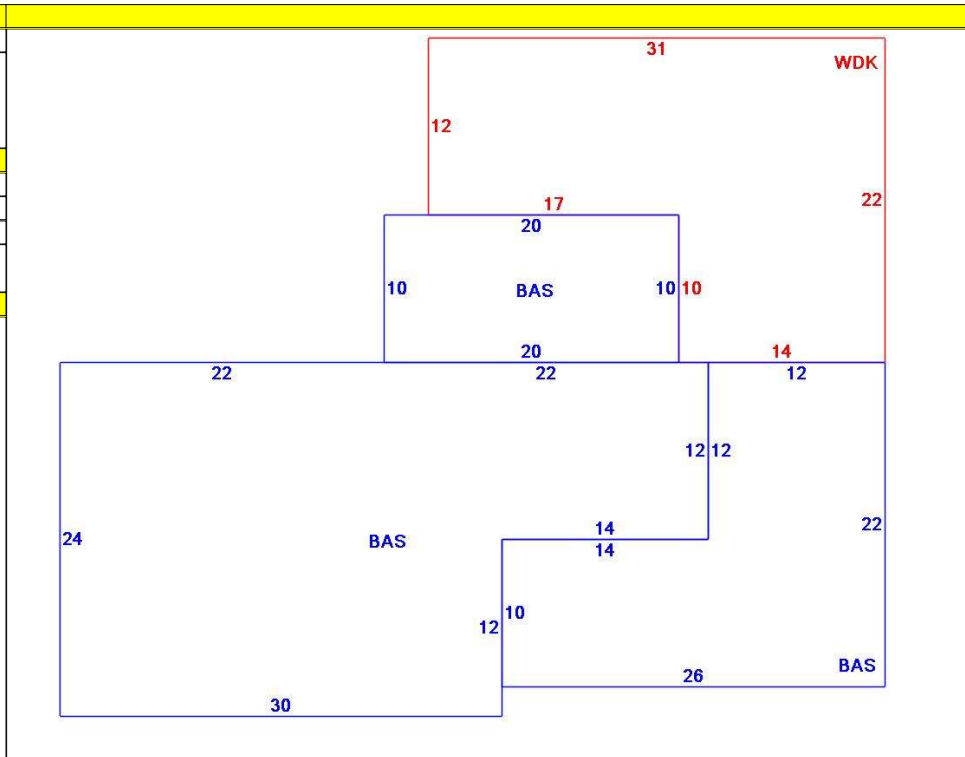

OB - OUTBUILDING & YARD ITEMS(L) / XF - BUILDING EXTRA FEATURES(B)										
Code	Description	L/B	Units	Unit Price	Yr Blt	Cond. Cd	% Gd	Grade	Grade Adj.	Appr. Value
WDC	Wood Decking	L	512	20.00	1998		58		0.00	5,600

BUILDING SUB-AREA SUMMARY SECTION						
Code	Description	Living Area	Floor Area	Eff Area	Unit Cost	Undeprec Value
BAS	First Floor	1,492	1,492	1,492	271.57	405,182
WDK	Wood Deck	0	512	0	0.00	0
Ttl Gross Liv / Lease Area		1,492	2,004	1,492		405,182

