

| CURRENT OWNER  |  | TOPO  | UTILITIES      | STRT / ROAD | LOCATION   | CURRENT ASSESSMENT |      |          |          | 801<br>FY2024<br>BARNSTABLE, MA<br><br><b>VISION</b> |         |
|--|--|---|----------------|-------------|--|--------------------|------|----------|----------|--|---------|
| DESOUSA, LAUDECEIA<br><br>10 CONCORD LN<br><br>OSTERVILLE MA 02655 |  | 1 Level   | 2 Public Water | 1 Paved     |  | Description        | Code | Assessed | Assessed |  |         |
|  |  |   | 4 Gas          |             |  | RESIDNTL           | 1010 | 404,000  | 404,000  |  |         |
|  |  |   | 6 Septic       |             |  | RES LAND           | 1010 | 158,800  | 158,800  |  |         |
| <b>SUPPLEMENTAL DATA</b>   |  |   |                |             |  | Total              |      |          |          | 562,800  | 562,800 |
|  |  | Alt Prcl ID<br>Split Zonin<br>BID Parcel<br>ResExpt Q<br>#DL 1 LOT 23<br>#DL 2<br>GIS ID F_959344_2701820 |                |             | Plan Ref. 326/71<br>Land Ct#<br>#SR<br>Life Estate<br>PP STATU<br>Assoc Pid# |                    |      |          |          |  |         |

| RECORD OF OWNERSHIP        |       | BK-VOL/PAGE | SALE DATE  | Q/U  | V/I        | SALE PRIC | VC   | PREVIOUS ASSESSMENTS (HISTORY) |       |         |          |         |         |      |      |         |
|----------------------------|-------|-------------|------------|------|------------|-----------|------|--------------------------------|-------|---------|----------|---------|---------|------|------|---------|
| Year                       | Code  | Assessed    | Year       | Code | Assessed V | Year      | Code | Assessed                       | Year  | Code    | Assessed |         |         |      |      |         |
| DESOUSA, LAUDECEIA         | 21910 | 0166        | 04-03-2007 | U    | I          | 305,000   | 1L   | 2023                           | 1010  | 353,900 | 2022     | 1010    | 307,400 | 2021 | 1010 | 252,700 |
| REO PROPERTIES CORP        | 21910 | 0164        | 04-03-2007 | U    | I          | 0         | 1L   |                                | 1010  | 144,400 |          | 1010    | 106,900 |      | 1010 | 106,900 |
| DB STRUCTURED PRODUCTS INC | 21910 | 0160        | 04-03-2007 | U    | I          | 251,195   | 1L   |                                |       |         |          |         |         |      | 1010 | 2,700   |
| BOTELHO, JOAO              | 20006 | 0179        | 07-01-2005 | Q    | I          | 390,000   | 00   | Total                          |       |         |          |         |         |      |      |         |
| ST JAMES, AMY E            | 13405 | 0075        | 12-04-2000 | Q    | I          | 157,500   | 00   | 498,300                        | Total | 414,300 | Total    | 362,300 |         |      |      |         |

| EXEMPTIONS |      |             | OTHER ASSESSMENTS |      |             |        |        |          |
|------------|------|-------------|-------------------|------|-------------|--------|--------|----------|
| Year       | Code | Description | Amount            | Code | Description | Number | Amount | Comm Int |
| Total      |      |             | 0.00              |      |             |        |        |          |

| ASSESSING NEIGHBORHOOD |           |   |         |        |
|------------------------|-----------|---|---------|--------|
| Nbhd                   | Nbhd Name | B | Tracing | Batch  |
| 0105                   |           |   |         | MARSTM |

| NOTES   |  |  |  |         |
|---|--|--|--|---------|
| This signature acknowledges a visit by a Data Collector or Assessor |  |  |  |         |
| APPRAISED VALUE SUMMARY   |  |  |  |         |
| Appraised Bldg. Value (Card)  |  |  |  | 342,200 |
| Appraised Xf (B) Value (Bldg)                                       |  |  |  | 59,100  |
| Appraised Ob (B) Value (Bldg)                                       |  |  |  | 2,700   |
| Appraised Land Value (Bldg)   |  |  |  | 158,800 |
| Special Land Value  |  |  |  | 0       |
| Total Appraised Parcel Value  |  |  |  | 562,800 |
| Valuation Method  |  |  |  | C       |
| Total Appraised Parcel Value  |  |  |  | 562,800 |

| BUILDING PERMIT RECORD |            |      |                |        |            |        |            |              | VISIT / CHANGE HISTORY |    |      |    |    |                            |
|------------------------|------------|------|----------------|--------|------------|--------|------------|--------------|------------------------|----|------|----|----|----------------------------|
| Permit Id              | Issue Date | Type | Description    | Amount | Insp Date  | % Comp | Date Comp  | Comments     | Date                   | Id | Type | Is | Cd | Purpost/Result             |
| 200700822              | 02-23-2007 | FB   | Finish Basemen | 3,000  | 11-01-2007 | 100    | 06-30-2007 | DEMO OLD BMT | 05-07-2020             | LS |      |    | FR | Field Review               |
| 77342                  | 06-17-2004 | RE   | Remodel        | 2,000  | 10-05-2004 | 100    | 01-01-2005 |              | 06-07-2017             | KM | 02   |    | 03 | Cycl Insp Comp             |
| B23578                 | 10-01-1981 | DW   | Dwelling       | 0      | 01-15-1982 | 100    | 12-31-1982 | MM 1 STOR    | 11-01-2007             | PT | 02   |    | 02 | Bldg Permit Completed      |
|                        |            |      |                |        |            |        |            |              | 01-16-2007             | PT | 02   |    | 14 | Cyclical Inspection        |
|                        |            |      |                |        |            |        |            |              | 12-21-2005             | PT | 02   |    | 01 | Meas/Est                   |
|                        |            |      |                |        |            |        |            |              | 10-05-2004             | MF | 02   |    | 02 | Bldg Permit Completed      |
|                        |            |      |                |        |            |        |            |              | 11-09-1998             | FS | 01   |    | 00 | Meas/Listed-Interior Acces |

| LAND LINE VALUATION SECTION |          |                |      |    |            |            |                        |         |            |       |       |           |                  |                    |            |            |         |
|-----------------------------|----------|----------------|------|----|------------|------------|------------------------|---------|------------|-------|-------|-----------|------------------|--------------------|------------|------------|---------|
| B                           | Use Code | Description    | Zone | LA | Land Units | Unit Price | Size Adj               | AC Disc | Site Index | Cond. | Nbhd. | Nbhd. Adj | Notes            | Location Adjustmen | Adj Unit P | Land Value |         |
| 1                           | 1010     | Single Fam M-0 | RF   | 3  | 0.520      | AC         | 176,344.00             | 1.73169 | 1.0000     | 5     | 1.00  | 0105      | 1.000            |                    | 1.0000     | 305,374.9  | 158,800 |
| Total Card Land Units       |          |                |      |    | 0.52       | AC         | Parcel Total Land Area |         |            |       |       | 0.52      | Total Land Value |                    |            | 158,800    |         |

| CONSTRUCTION DETAIL |    |                | CONSTRUCTION DETAIL (CONTINUED) |    |             |
|---------------------|----|----------------|---------------------------------|----|-------------|
| Element             | Cd | Description    | Element                         | Cd | Description |
| Style               | 01 | Ranch          |                                 |    |             |
| Model               | 01 | Residential    |                                 |    |             |
| Grade:              | C  | Average        |                                 |    |             |
| Stories             | 1  | 1 Story        |                                 |    |             |
| Exterior Wall 1     | 11 | Clapboard      |                                 |    |             |
| Exterior Wall 2     | 06 | Vertical Sidin |                                 |    |             |
| Roof Structure      | 03 | Gable/Hip      |                                 |    |             |
| Roof Cover          | 03 | Asph/F Gls/Cmp |                                 |    |             |
| Interior Wall 1     | 05 | Drywall        |                                 |    |             |
| Interior Wall 2     |    |                |                                 |    |             |
| Interior Floor 1    | 12 | Hardwood       |                                 |    |             |
| Interior Floor 2    | 14 | Carpet         |                                 |    |             |
| Heat Fuel           | 03 | Gas            |                                 |    |             |
| Heat Type           | 05 | Hot Water      |                                 |    |             |
| AC Type             | 03 | Central        |                                 |    |             |
| Bedrooms            | 03 | 3 Bedrooms     |                                 |    |             |
| Full Baths          | 3  |                |                                 |    |             |
| Half Baths          | 0  |                |                                 |    |             |
| Extra Fixtures      |    |                |                                 |    |             |
| Total Rooms         | 5  | 5 Rooms        |                                 |    |             |
| Bath Style          | 04 | Typical for Gr |                                 |    |             |
| Kitchen Style       | 04 | Typical for Gr |                                 |    |             |
| Occupancy           |    |                |                                 |    |             |
| Usrflid 105         |    |                |                                 |    |             |
| Accessory Apt       |    |                |                                 |    |             |
| Foundation Alt      | 01 | Poured Conc.   |                                 |    |             |
| Rms Prts            |    |                |                                 |    |             |
| Bath Split          | 30 | 3 Full-0 Half  |                                 |    |             |

| CONDO DATA  |      |             |         |
|-------------|------|-------------|---------|
| Parcel Id   | C    | Owne        | 0.0     |
|             |      |             |         |
| Adjust Type | Code | Description | Factor% |
| Condo Flr   |      |             |         |
| Condo Unit  |      |             |         |

| COST / MARKET VALUATION  |         |
|--------------------------|---------|
| Building Value New       | 417,355 |
| Year Built               | 1981    |
| Effective Year Built     | 1996    |
| Depreciation Code        | A       |
| Remodel Rating           |         |
| Year Remodeled           |         |
| Depreciation %           | 18      |
| Functional Obsol         | 0       |
| External Obsol           | 0       |
| Trend Factor             | 1       |
| Condition                |         |
| Condition %              |         |
| Percent Good             | 82      |
| RCNLD                    | 342,200 |
| Dep % Ovr                |         |
| Dep Ovr Comment          |         |
| Misc Imp Ovr             |         |
| Misc Imp Ovr Comment     |         |
| Cost to Cure Ovr         |         |
| Cost to Cure Ovr Comment |         |

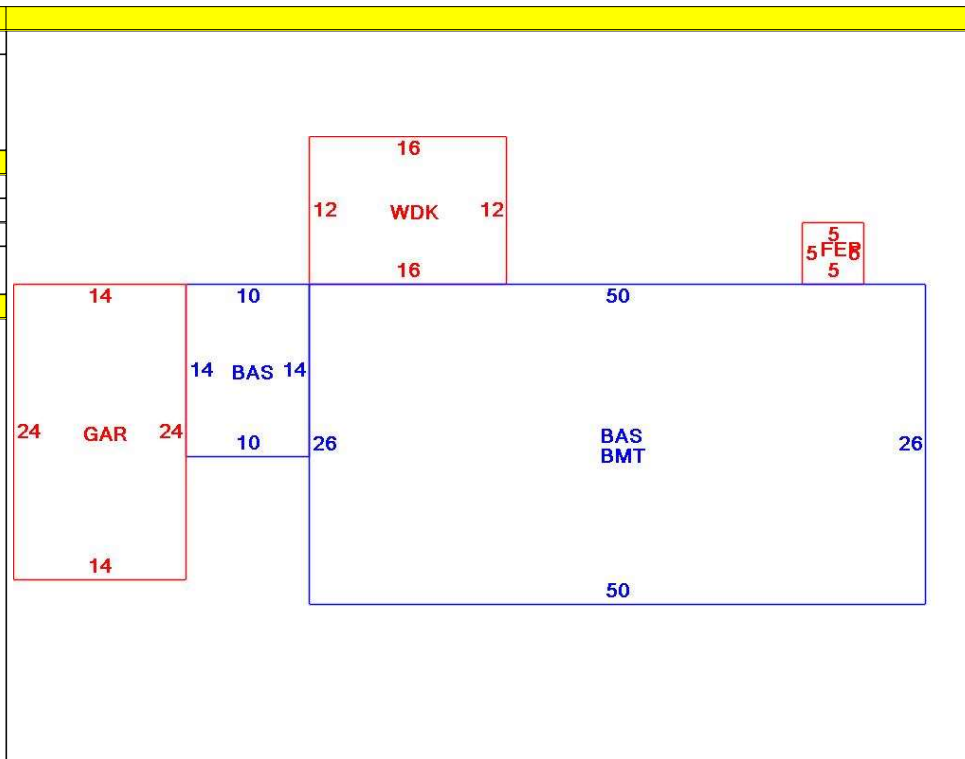

| OB - OUTBUILDING & YARD ITEMS(L) / XF - BUILDING EXTRA FEATURES(B) |                 |     |       |            |        |          |      |       |            |             |
|--|-----------------|-----|-------|------------|--------|----------|------|-------|------------|-------------|
| Code   | Description     | L/B | Units | Unit Price | Yr Blt | Cond. Cd | % Gd | Grade | Grade Adj. | Appr. Value |
| FPL1   | Fireplace 1 sto | B   | 1     | 5000.00    | 1998   |          | 82   |       | 0.00       | 4,100       |
| BFA  | Bsmt Fin-Avg    | B   | 1,000 | 17.36      | 1998   |          | 82   |       | 0.00       | 14,200      |
| WDC  | Wood Decking    | L   | 192   | 20.00      | 1998   |          | 58   |       | 0.00       | 2,700       |
| FEP  | Enclosed porc   | B   | 25    | 70.00      | 1998   |          | 82   |       | 0.00       | 2,900       |
| GAR  | Attached Gara   | B   | 336   | 40.00      | 1998   |          | 82   |       | 0.00       | 11,800      |
| BMT  | Basement-Unfi   | B   | 1,300 | 26.01      | 1998   |          | 82   |       | 0.00       | 26,100      |

| BUILDING SUB-AREA SUMMARY SECTION |                 |             |            |          |           |                |
|-----------------------------------|-----------------|-------------|------------|----------|-----------|----------------|
| Code                              | Description     | Living Area | Floor Area | Eff Area | Unit Cost | Undeprec Value |
| BAS                               | First Floor     | 1,440       | 1,440      | 1,440    | 289.83    | 417,355        |
| BMT                               | Basement Area   | 0           | 1,300      | 0        | 0.00      | 0              |
| FEP                               | Enclosed Porch  | 0           | 25         | 0        | 0.00      | 0              |
| GAR                               | Attached Garage | 0           | 336        | 0        | 0.00      | 0              |
| WDK                               | Wood Deck       | 0           | 192        | 0        | 0.00      | 0              |
| Ttl Gross Liv / Lease Area        |                 | 1,440       | 3,293      | 1,440    |           | 417,355        |

