

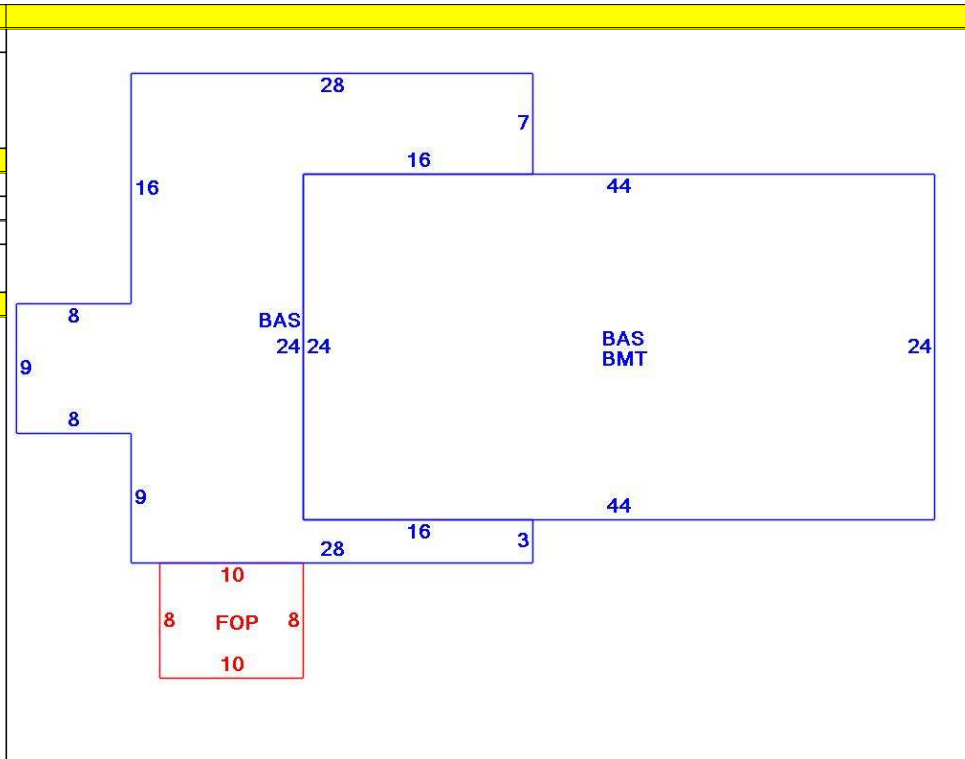

CONSTRUCTION DETAIL			CONSTRUCTION DETAIL (CONTINUED)		
Element	Cd	Description	Element	Cd	Description
Style	01	Ranch			
Model	01	Residential			
Grade:	C	Average			
Stories	1	1 Story			
Exterior Wall 1	14	Wood Shingle			
Exterior Wall 2					
RooF Structure	03	Gable/Hip			
RooF Cover	03	Asph/F Gls/Cmp			
Interior Wall 1	05	Drywall			
Interior Wall 2					
Interior Floor 1	14	Carpet			
Interior Floor 2					
Heat Fuel	02	Oil			
Heat Type	05	Hot Water			
AC Type	01	None			
Bedrooms	03	3 Bedrooms			
Full Baths	2				
Half Baths	0				
Extra Fixtures					
Total Rooms	6	6 Rooms			
Bath Style					
Kitchen Style					
Occupancy					
UsrflD 105					
Accessory Apt					
Foundation Alt	08	Mixed			
Rms Prts					
Bath Split	20	2 Full-0 Half			

CONDO DATA				
Parcel Id		C	Owne	0.0
Adjust Type	Code	Description	Factor%	
Condo Flr				
Condo Unit				

COST / MARKET VALUATION	
Building Value New	449,559
Year Built	1983
Effective Year Built	1997
Depreciation Code	A
Remodel Rating	
Year Remodeled	
Depreciation %	17
Functional Obsol	0
External Obsol	0
Trend Factor	1
Condition	
Condition %	
Percent Good	83
RCNLD	373,100
Dep % Ovr	
Dep Ovr Comment	
Misc Imp Ovr	
Misc Imp Ovr Comment	
Cost to Cure Ovr	
Cost to Cure Ovr Comment	



OB - OUTBUILDING & YARD ITEMS(L) / XF - BUILDING EXTRA FEATURES(B)										
Code	Description	L/B	Units	Unit Price	Yr Blt	Cond. Cd	% Gd	Grade	Grade Adj.	Appr. Value
FPL1	Fireplace 1 sto	B	1	5000.00	1999		83		0.00	4,200
BMT	Basement-Unfi	B	1,056	26.01	1999		83		0.00	22,900
FOP	Open Porch-ro	B	80	55.00	1999		83		0.00	4,000

BUILDING SUB-AREA SUMMARY SECTION						
Code	Description	Living Area	Floor Area	Eff Area	Unit Cost	Undeprec Value
BAS	First Floor	1,696	1,696	1,696	265.07	449,559
BMT	Basement Area	0	1,056	0	0.00	0
FOP	Open Porch	0	80	0	0.00	0
Ttl Gross Liv / Lease Area		1,696	2,832	1,696		449,559

