

| CURRENT OWNER | | TOPO | | UTILITIES | | STRT / ROAD | | LOCATION | | CURRENT ASSESSMENT | | | |
|--|--|---|--------|-----------|--------------|---|------------|----------|---------------|-------------------------------------|----------------------|--------------------------------|--------------------------------|
| KELLEHER, ELLEN M 80 LIBERTY LN | | 1 | Level | 2 | Public Water | 1 | Paved | 1 | Lake/Pond Fro | Description RESIDNTL RES LAND | Code 1010 1010 | Assessed 521,500 313,200 | Assessed 521,500 313,200 |
| | | 4 | Gas | | | 1 | Excel View | | | | | | |
| | | 6 | Septic | | | | | | | | | | |
| MARSTONS MIL MA 02648 | | SUPPLEMENTAL DATA | | | | | | | | | | | |
| | | Alt Prcl ID Split Zonin BID Parcel ResExpt Q INFO: #DL 1 LOT 3 #DL 2 | | | | Plan Ref. Land Ct# 42122-B #SR Life Estate PP STATU | | | | Assoc Pid# | | | |
| | | GIS ID F_959271_2705538 | | | | | | | | | | | |
| | | | | | | | | | | Total | | 834,700 | 834,700 |

801
 FY2024
 BARNSTABLE, MA
VISION

| RECORD OF OWNERSHIP | | BK-VOL/PAGE | | SALE DATE | | Q/U | | V/I | | SALE PRIC | | VC | | PREVIOUS ASSESSMENTS (HISTORY) | | | | | | | | |
|----------------------------------|--|-------------|---|------------|---|-----|--------|-----|------|-----------|---------|---------|-------|--------------------------------|----------|-------|---------|----------|---------|---------|----------|--------|
| KELLEHER, ELLEN M VOS, JOAN T | | C153798 | 0 | 06-30-1999 | Q | V | 92,000 | 1P | | | | | Year | Code | Assessed | Year | Code | Assessed | Year | Code | Assessed | |
| | | C129423 | 0 | 02-25-1993 | U | V | 100 | A | 2023 | 1010 | 440,600 | 2022 | 1010 | 364,800 | 2021 | 1010 | 202,600 | 2021 | 1010 | 323,100 | | |
| | | | | | | | | | | 2023 | 1010 | 311,200 | | | | | 2021 | 1010 | 215,300 | 2021 | 1010 | 10,100 |
| | | | | | | | | | | Total | | 751,800 | Total | | 567,400 | Total | | 548,500 | | | | |

| EXEMPTIONS | | | | OTHER ASSESSMENTS | | | |
|------------|------|--------------------------|--------|-------------------|-------------|--------|--------|
| Year | Code | Description | Amount | Code | Description | Number | Amount |
| 2024 | N5C | NO RESIDENTIAL EXEMPTION | | | | | |
| | | | Total | 0.00 | | | |

| ASSESSING NEIGHBORHOOD | | | |
|------------------------|-----------|---|---------|
| Nbhd | Nbhd Name | B | Tracing |
| 0108 | | | MARSTM |

| NOTES | | | |
|---|--|--|---------|
| This signature acknowledges a visit by a Data Collector or Assessor | | | |
| APPRAISED VALUE SUMMARY | | | |
| Appraised Bldg. Value (Card) | | | 437,500 |
| Appraised Xf (B) Value (Bldg) | | | 72,800 |
| Appraised Ob (B) Value (Bldg) | | | 11,200 |
| Appraised Land Value (Bldg) | | | 313,200 |
| Special Land Value | | | 0 |
| Total Appraised Parcel Value | | | 834,700 |
| Valuation Method | | | C |
| Total Appraised Parcel Value | | | 834,700 |

| BUILDING PERMIT RECORD | | | | | | | | | VISIT / CHANGE HISTORY | | | | | |
|------------------------|------------|------|----------------|---------|------------|--------|------------|------------------------|------------------------|----|------|----|----|------------------|
| Permit Id | Issue Date | Type | Description | Amount | Insp Date | % Comp | Date Comp | Comments | Date | Id | Type | Is | Cd | Purpost/Result |
| 201101732 | 04-07-2011 | IN | Insulation | 2,700 | 06-30-2012 | 100 | 06-30-2012 | AIR SEAL-INSULATE | 01-09-2023 | DB | 01 | 1 | 03 | Cycl Insp Comp |
| 200801237 | 05-05-2008 | FB | Finish Basemen | 20,000 | 09-05-2008 | 100 | 06-30-2009 | FB BTH, PLAYRM, FAMRM, | 05-15-2020 | LS | | | FR | Field Review |
| 42291 | 11-09-1999 | AD | Addition | 20,000 | 01-01-2000 | 100 | 01-01-2001 | Second Floor-3BR 2BA | 02-11-2019 | TR | 03 | | 16 | In Office Review |
| 39275 | 06-21-1999 | DW | Dwelling | 117,070 | 01-01-2000 | 100 | 01-01-2001 | | 05-27-2014 | SR | 02 | | 03 | Cycl Insp Comp |
| | | | | | | | | | 02-23-2011 | NF | 03 | | 16 | In Office Review |

| LAND LINE VALUATION SECTION | | | | | | | | | | | | | | | | |
|-----------------------------|----------|----------------|------|----|------------|---------------|------------------------|---------|------------|-------|-------|-----------|------------------|--------------------|------------|------------|
| B | Use Code | Description | Zone | LA | Land Units | Unit Price | Size Adj | AC Disc | Site Index | Cond. | Nbhd. | Nbhd. Adj | Notes | Location Adjustmen | Adj Unit P | Land Value |
| 1 | 1010 | Single Fam M-0 | RF | 3 | 1.000 | AC 176,344.00 | 1.00000 | 1.0000 | 5 | 1.00 | 0108 | 1.700 | ROUND POND | 1.0000 | 299,784.8 | 299,800 |
| 1 | 1010 | Single Fam M-0 | RF | 3 | 0.550 | AC 14,250.00 | 1.00000 | 1.0000 | 0 | 1.00 | 0108 | 1.700 | | 1.0000 | 24,225 | 13,300 |
| 1 | 1010 | Single Fam M-0 | RF | 3 | 0.050 | AC 2,375.00 | 1.00000 | 1.0000 | 0 | 1.00 | WTLD | 1.000 | WETLAND | 1.0000 | 2,375 | 100 |
| Total Card Land Units | | | | | 1.60 | AC | Parcel Total Land Area | | | | | 1.60 | Total Land Value | | | 313,200 |

| CONSTRUCTION DETAIL | | | CONSTRUCTION DETAIL (CONTINUED) | | |
|---------------------|----|----------------|---------------------------------|----|-------------|
| Element | Cd | Description | Element | Cd | Description |
| Style | 03 | Colonial | | | |
| Model | 01 | Residential | | | |
| Grade: | C | Average | | | |
| Stories | 2 | 2 Stories | | | |
| Exterior Wall 1 | 14 | Wood Shingle | | | |
| Exterior Wall 2 | 11 | Clapboard | | | |
| RooF Structure | 03 | Gable/Hip | | | |
| RooF Cover | 03 | Asph/F Gls/Cmp | | | |
| Interior Wall 1 | 03 | Plastered | | | |
| Interior Wall 2 | | | | | |
| Interior Floor 1 | 14 | Carpet | | | |
| Interior Floor 2 | | | | | |
| Heat Fuel | 03 | Gas | | | |
| Heat Type | 05 | Hot Water | | | |
| AC Type | 03 | Central | | | |
| Bedrooms | 04 | 4 Bedrooms | | | |
| Full Baths | 3 | | | | |
| Half Baths | 0 | | | | |
| Extra Fixtures | | | | | |
| Total Rooms | 11 | | | | |
| Bath Style | | | | | |
| Kitchen Style | | | | | |
| Occupancy | | | | | |
| UsrflD 105 | | | | | |
| Accessory Apt | | | | | |
| Foundation Alt | 01 | Poured Conc. | | | |
| Rms Prts | | | | | |
| Bath Split | 30 | 3 Full-0 Half | | | |

| CONDO DATA | | | | |
|-------------|------|-------------|---------|-----|
| Parcel Id | | C | Owne | 0.0 |
| Adjust Type | Code | Description | Factor% | |
| Condo Flr | | | | |
| Condo Unit | | | | |

| COST / MARKET VALUATION | | |
|--------------------------|---------|---------|
| Building Value New | | 486,127 |
| Year Built | | 2001 |
| Effective Year Built | | 2006 |
| Depreciation Code | | A |
| Remodel Rating | | |
| Year Remodeled | | |
| Depreciation % | 10 | |
| Functional Obsol | 0 | |
| External Obsol | 0 | |
| Trend Factor | 1 | |
| Condition | | |
| Condition % | | |
| Percent Good | 90 | |
| RCNLD | 437,500 | |
| Dep % Ovr | | |
| Dep Ovr Comment | | |
| Misc Imp Ovr | | |
| Misc Imp Ovr Comment | | |
| Cost to Cure Ovr | | |
| Cost to Cure Ovr Comment | | |

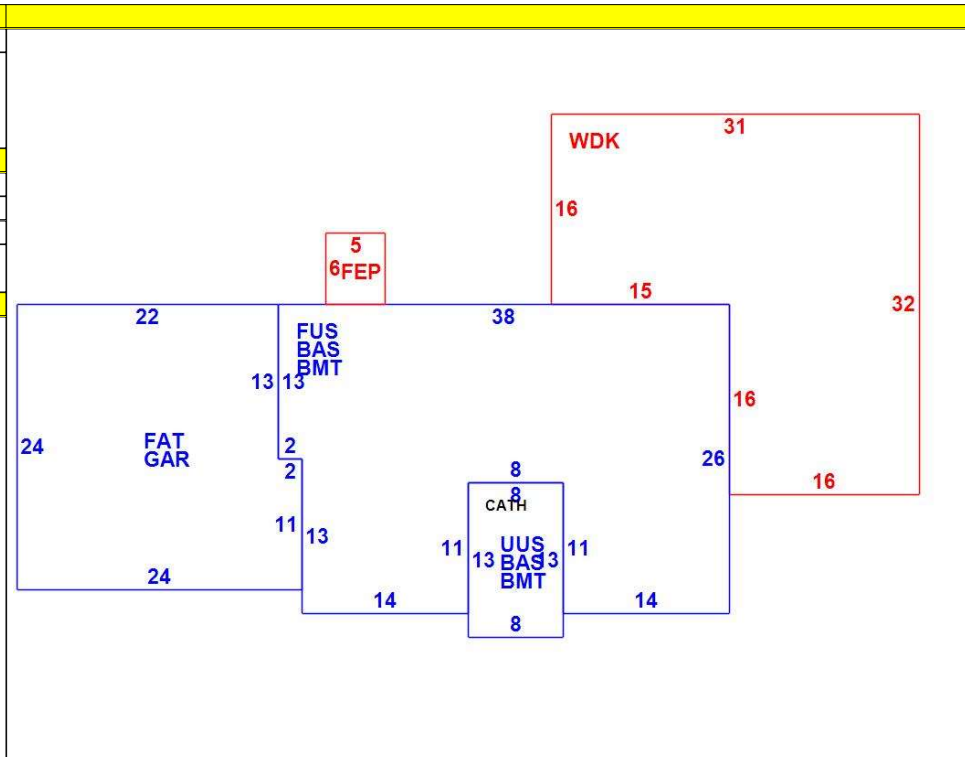

| OB - OUTBUILDING & YARD ITEMS(L) / XF - BUILDING EXTRA FEATURES(B) | | | | | | | | | | |
|--|-----------------|-----|-------|------------|--------|----------|------|-------|------------|-------------|
| Code | Description | L/B | Units | Unit Price | Yr Blt | Cond. Cd | % Gd | Grade | Grade Adj. | Appr. Value |
| FPL3 | Fireplace 2 sto | B | 1 | 7000.00 | | | 90 | | 0.00 | 6,300 |
| BFA1 | Bsmt Fin-Goo | B | 733 | 32.56 | | | 90 | | 0.00 | 21,500 |
| WDC | Wood Decking | L | 752 | 20.00 | 2006 | | 74 | | 0.00 | 10,100 |
| GAR | Attached Gara | B | 550 | 40.00 | 2008 | | 90 | | 0.00 | 17,800 |
| BMT | Basement-Unfi | B | 978 | 26.01 | 2008 | | 90 | | 0.00 | 23,600 |
| SHED | Shed | L | 80 | 18.00 | 2006 | | 74 | | 0.00 | 1,100 |
| FEP | Enclosed porc | B | 30 | 70.00 | | | 90 | | 0.00 | 3,600 |

| BUILDING SUB-AREA SUMMARY SECTION | | | | | | |
|-----------------------------------|-------------------------|-------------|------------|----------|-----------|----------------|
| Code | Description | Living Area | Floor Area | Eff Area | Unit Cost | Undeprec Value |
| BAS | First Floor | 978 | 978 | 978 | 240.30 | 235,013 |
| BMT | Basement Area | 0 | 978 | 0 | 0.00 | 0 |
| FAT | Attic, Finished | 83 | 550 | 83 | 36.26 | 19,945 |
| FEP | Enclosed Porch | 0 | 30 | 0 | 0.00 | 0 |
| FUS | Upper Story | 874 | 874 | 874 | 240.30 | 210,022 |
| GAR | Attached Garage | 0 | 550 | 0 | 0.00 | 0 |
| UUS | Upper Story, Unfinished | 0 | 104 | 88 | 203.33 | 21,146 |
| WDK | Wood Deck | 0 | 752 | 0 | 0.00 | 0 |
| Ttl Gross Liv / Lease Area | | 1,935 | 4,816 | 2,023 | | 486,126 |

