

CURRENT OWNER		TOPO	UTILITIES	STRT / ROAD	LOCATION	CURRENT ASSESSMENT			
GANNEY, GERARD F & KATHLEEN 65 TRACEY RD COTUIT MA 02635		1 Level	2 Public Water	1 Paved		Description	Code	Assessed	Assessed
		4 Gas				RESIDENTL	1010	641,700	641,700
		6 Septic				RES LAND	1010	342,900	342,900
SUPPLEMENTAL DATA									
Alt Prcl ID			Plan Ref.						
Split Zonin			Land Ct# 11260-D						
BID Parcel			#SR						
ResExpt Q			Life Estate						
#DL 1 LOT 19			PP STATU						
#DL 2									
GIS ID F_940879_2680905			Assoc Pid#						
						Total		984,600	984,600

801
 FY2024
 BARNSTABLE, MA

VISION

RECORD OF OWNERSHIP		BK-VOL/PAGE	SALE DATE	Q/U	V/I	SALE PRIC	VC	PREVIOUS ASSESSMENTS (HISTORY)						
GANNEY, GERARD F & KATHLEEN		C165902	0	07-12-2002	Q	I	517,500	00	Year	Code	Assessed	Year	Code	Assessed
SAYLOR, CARLYLE L & AVIS J		C146449	0	11-05-1997	Q	I	227,000	00	2023	1010	574,600	2022	1010	481,000
BURTON, G ROY & PATRICIA S		C87785	0	01-15-1982	Q	V	22,500	00		1010	318,800		1010	220,400
									Total		893,400	Total		701,400
									Total			Total		629,200

EXEMPTIONS				OTHER ASSESSMENTS			
Year	Code	Description	Amount	Code	Description	Number	Amount
2024	N5C	NO RESIDENTIAL EXEMPTION	0.00				
Total			0.00				

This signature acknowledges a visit by a Data Collector or Assessor

APPRAISED VALUE SUMMARY

Appraised Bldg. Value (Card)	581,100
Appraised Xf (B) Value (Bldg)	51,000
Appraised Ob (B) Value (Bldg)	9,600
Appraised Land Value (Bldg)	342,900
Special Land Value	0
Total Appraised Parcel Value	984,600
Valuation Method	C
Total Appraised Parcel Value	984,600

ASSESSING NEIGHBORHOOD		B		Tracing		Batch	
Nbhd	Nbhd Name					COTUIT	
0110							

NOTES

BUILDING PERMIT RECORD								VISIT / CHANGE HISTORY						
Permit Id	Issue Date	Type	Description	Amount	Insp Date	% Comp	Date Comp	Comments	Date	Id	Type	Is	Cd	Purpost/Result
EXPR-23-1	08-15-2023	835	Sid/Wind/Roof/	25,000		100		roof and skylite replacement	07-23-2021	CK	01		03	Cycl Insp Comp
201005764	10-29-2010	OT	Other	7,600	04-07-2011	100	06-30-2012	INSTL SPRL STRS TO 2ND F	06-04-2020	DM			FR	Field Review
200904792	10-06-2009	OB	Out Building	0	12-14-2010	100	06-30-2011	8X12 SHED	05-12-2016	JR	03		16	In Office Review
86665	09-16-2005	AD	Addition	75,000	11-06-2006	100	06-30-2007	21 x 21 KIT ADDN	06-04-2012	RB	03		16	In Office Review
B34360	05-01-1991	AD	Addition	6,000	01-15-1992	100	12-31-1992	CO ADD'N	11-18-2011	RB	03		16	In Office Review
B31051	08-01-1987	AD	Addition	20,000	01-15-1988	100	12-31-1988	CO DORMER	05-19-2011	TR	03		16	In Office Review
B24586	11-01-1982	DW	Dwelling	0	01-15-1984	100	12-31-1988	CO 1.5 DW	04-12-2011	RB	03		02	Bldg Permit Completed

LAND LINE VALUATION SECTION

B	Use Code	Description	Zone	LA	Land Units	Unit Price	Size Adj	AC Disc	Site Index	Cond.	Nbhd.	Nbhd. Adj	Notes	Location Adjustmen	Adj Unit P	Land Value	
1	1010	Single Fam M-0	RF	2	0.460	AC	176,344.00	1.92125	1.0000	5	1.00	0109	2.200		1.0000	745,370.8	342,900

Total Card Land Units 0.46 AC Parcel Total Land Area 0.46

Total Land Value 342,900

CONSTRUCTION DETAIL			CONSTRUCTION DETAIL (CONTINUED)		
Element	Cd	Description	Element	Cd	Description
Style	04	Cape Cod			
Model	01	Residential			
Grade:	C+	Average Plus			
Stories	1.75	1 3/4 Stories			
Exterior Wall 1	14	Wood Shingle			
Exterior Wall 2	11	Clapboard			
RooF Structure	03	Gable/Hip			
RooF Cover	03	Asph/F Gls/Cmp			
Interior Wall 1	05	Drywall			
Interior Wall 2					
Interior Floor 1	12	Hardwood			
Interior Floor 2	14	Carpet			
Heat Fuel	03	Gas			
Heat Type	05	Hot Water			
AC Type	03	Central			
Bedrooms	03	3 Bedrooms			
Full Baths	3				
Half Baths	0				
Extra Fixtures					
Total Rooms	8	8 Rooms			
Bath Style					
Kitchen Style					
Occupancy					
Usrflid 105					
Accessory Apt					
Foundation Alt	01	Poured Conc.			
Rms Prts					
Bath Split	30	3 Full-0 Half			

CONDO DATA				
Parcel Id	C	B	S	Ownr 0.0
Adjust Type	Code	Description	Factor%	
Condo Flr				
Condo Unit				

COST / MARKET VALUATION	
Building Value New	667,889
Year Built	1983
Effective Year Built	2002
Depreciation Code	G
Remodel Rating	
Year Remodeled	
Depreciation %	13
Functional Obsol	0
External Obsol	0
Trend Factor	1
Condition	
Condition %	
Percent Good	87
RCNLD	581,100
Dep % Ovr	
Dep Ovr Comment	
Misc Imp Ovr	
Misc Imp Ovr Comment	
Cost to Cure Ovr	
Cost to Cure Ovr Comment	

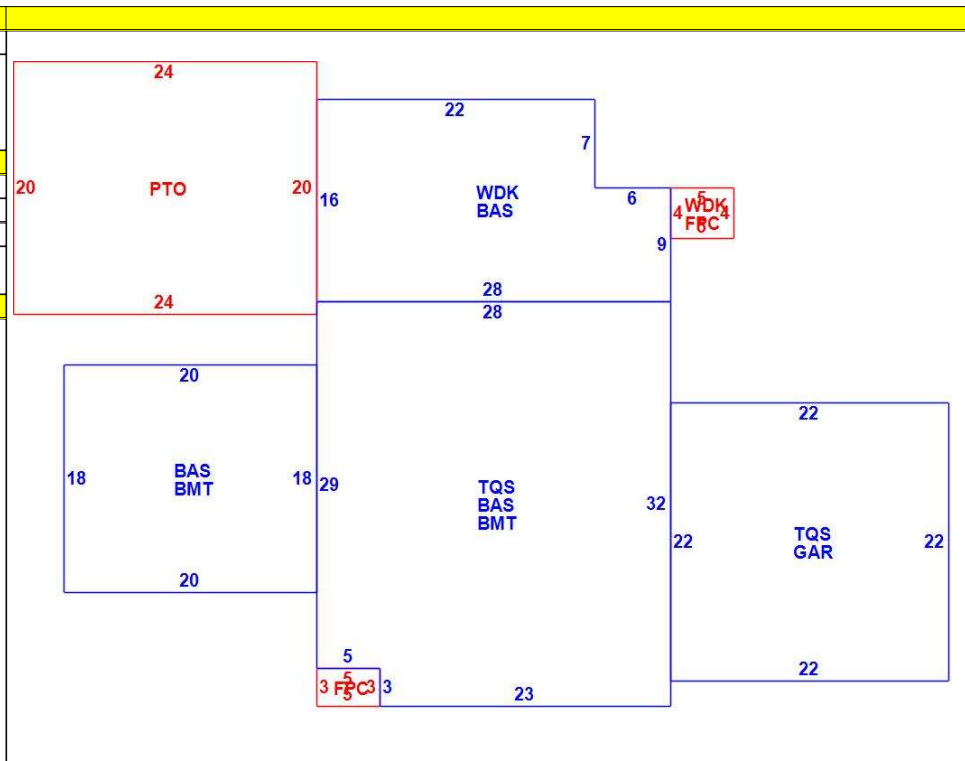

OB - OUTBUILDING & YARD ITEMS(L) / XF - BUILDING EXTRA FEATURES(B)										
Code	Description	L/B	Units	Unit Price	Yr Blt	Cond. Cd	% Gd	Grade	Grade Adj.	Appr. Value
FPL1	Fireplace 1 sto	B	1	5000.00	2004		87		0.00	4,400
FPLG	Gas Fireplace	B	1	2500.00	2004		87		0.00	2,200
WDC	Wood Decking	L	426	20.00	1999		60		0.00	4,900
PAT2	Patio-Good	L	480	9.94	1999		80		0.00	3,700
FOPC	Open Prch-roo	B	35	55.00	2004		87		0.00	1,900
GAR	Attached Gara	B	484	40.00	2004		87		0.00	15,800
BMT	Basement-Unfi	B	1,241	26.01	2004		87		0.00	26,700
SHED	Shed	L	96	18.00	1999		60		0.00	1,000

BUILDING SUB-AREA SUMMARY SECTION						
Code	Description	Living Area	Floor Area	Eff Area	Unit Cost	Undeprec Value
BAS	First Floor	1,647	1,647	1,647	263.57	434,101
BMT	Basement Area	0	1,241	0	0.00	0
FPC	Open Porch Conc. Floor	0	35	0	0.00	0
GAR	Attached Garage	0	484	0	0.00	0
PTO	Patio	0	480	0	0.00	0
TQS	Three Quarter Story	887	1,365	887	171.27	233,787
WDK	Wood Deck	0	426	0	0.00	0
Ttl Gross Liv / Lease Area		2,534	5,678	2,534		667,888

