

| CURRENT OWNER | | TOPO | UTILITIES | STRT / ROAD | LOCATION | CURRENT ASSESSMENT | | | |
|---|--|---------|-----------------|-------------|----------|--------------------|------|-----------|-----------|
| LALIBERTE, ROBERT J & THERESE 87 CARLSON LANE WEST BARNSTA MA 02668 | | 1 Level | 6 Septic | 1 Paved | | Description | Code | Assessed | Assessed |
| | | | 5 Well | | | RESIDNTL | 1010 | 873,200 | 873,200 |
| | | | 4 Gas | | | RES LAND | 1010 | 303,900 | 303,900 |
| SUPPLEMENTAL DATA | | | | | | | | | |
| Alt Prcl ID | | | Plan Ref. 389/5 | | | | | | |
| Split Zonin | | | Land Ct# | | | | | | |
| BID Parcel | | | #SR | | | | | | |
| ResExpt Q YES: | | | Life Estate | | | | | | |
| #DL 1 LOT 27 | | | PP STATU | | | | | | |
| #DL 2 | | | | | | | | | |
| GIS ID F_958417_2723208 | | | Assoc Pid# | | | | | | |
| | | | | | | Total | | 1,177,100 | 1,177,100 |

801
 FY2024
 BARNSTABLE, MA

VISION

| RECORD OF OWNERSHIP | | BK-VOL/PAGE | SALE DATE | Q/U | V/I | SALE PRIC | VC | PREVIOUS ASSESSMENTS (HISTORY) | | | | | | | | |
|---------------------------------|-------|-------------|------------|-----|-----|-----------|----|--------------------------------|------|-----------|-------|------|----------|-------|--|---------|
| LALIBERTE, ROBERT J & THERESE M | 26634 | 0302 | 08-30-2012 | Q | I | 575,000 | 00 | Year | Code | Assessed | Year | Code | Assessed | | | |
| DOLAN, RAYMOND J & DAWN C | 13844 | 0100 | 05-18-2001 | Q | I | 620,000 | 00 | 2023 | 1010 | 779,100 | 2022 | 1010 | 648,200 | | | |
| SELLARS, PETER C & DEBORAH C O | 10926 | 0016 | 08-29-1997 | Q | I | 410,000 | 00 | | 1010 | 301,100 | | 1010 | 193,900 | | | |
| SELLARS, RICHARD B | 10522 | 0214 | 12-12-1996 | U | I | 410,000 | 1A | | | | | 1010 | 5,800 | | | |
| SELLARS, RICHARD B | 10512 | 0170 | 12-05-1996 | Q | I | 369,000 | 00 | | | | | | | | | |
| | | | | | | | | Total | | 1,080,200 | Total | | 842,100 | Total | | 759,700 |

| EXEMPTIONS | | | | OTHER ASSESSMENTS | | | | This signature acknowledges a visit by a Data Collector or Assessor | | | | |
|------------|------|-----------------------|--------|-------------------|-------------|--------|--------|---|--|--|--|--|
| Year | Code | Description | Amount | Code | Description | Number | Amount | Comm Int | | | | |
| 2014 | 5C | RESIDENTIAL EXEMPTION | 0.00 | | | | | | | | | |
| | | | Total | | | | | | | | | |
| | | | 0.00 | | | | | | | | | |

| ASSESSING NEIGHBORHOOD | | | | APPROAISED VALUE SUMMARY | | | |
|------------------------|-----------|---|---------|--------------------------|-------------------------------|-----------|--|
| Nbhd | Nbhd Name | B | Tracing | Batch | | | |
| 0108 | | | | WBARNS | Appraised Bldg. Value (Card) | 812,900 | |
| | | | | | Appraised Xf (B) Value (Bldg) | 54,500 | |
| | | | | | Appraised Ob (B) Value (Bldg) | 5,800 | |
| | | | | | Appraised Land Value (Bldg) | 303,900 | |
| | | | | | Special Land Value | 0 | |
| | | | | | Total Appraised Parcel Value | 1,177,100 | |
| | | | | | Valuation Method | C | |
| | | | | | Total Appraised Parcel Value | 1,177,100 | |

| NOTES | | | | | | | | | | VISIT / CHANGE HISTORY | | | | | |
|-------|--|--|--|--|--|--|--|--|--|------------------------|----|------|----|----|-----------------------|
| | | | | | | | | | | Date | Id | Type | Is | Cd | Purpost/Result |
| | | | | | | | | | | 05-20-2020 | DM | | | FR | Field Review |
| | | | | | | | | | | 04-27-2017 | SR | 02 | | 14 | Cyclical Inspection |
| | | | | | | | | | | 05-05-2015 | JR | 03 | | 03 | Cycl Insp Comp |
| | | | | | | | | | | 07-17-2013 | TR | 22 | | 22 | Change of Address |
| | | | | | | | | | | 07-16-2013 | GC | 03 | | 16 | In Office Review |
| | | | | | | | | | | 04-27-2009 | JG | 03 | | 16 | In Office Review |
| | | | | | | | | | | 08-19-2008 | MK | 02 | | 02 | Bldg Permit Completed |

| BUILDING PERMIT RECORD | | | | | | | | | | VISIT / CHANGE HISTORY | | | | | |
|------------------------|------------|------|-------------|---------|------------|--------|------------|------------------------|--|------------------------|----|------|----|----|-----------------------|
| Permit Id | Issue Date | Type | Description | Amount | Insp Date | % Comp | Date Comp | Comments | | Date | Id | Type | Is | Cd | Purpost/Result |
| 200802318 | 05-21-2008 | RE | Remodel | 31,000 | 08-19-2008 | 100 | 06-30-2009 | NEW KIT CAB,RETILE BTH | | 05-20-2020 | DM | | | FR | Field Review |
| B32905 | 05-01-1989 | DW | Dwelling | 175,000 | 01-15-1990 | 100 | | WB 11/2 S | | 04-27-2017 | SR | 02 | | 14 | Cyclical Inspection |
| | | | | | | | | | | 05-05-2015 | JR | 03 | | 03 | Cycl Insp Comp |
| | | | | | | | | | | 07-17-2013 | TR | 22 | | 22 | Change of Address |
| | | | | | | | | | | 07-16-2013 | GC | 03 | | 16 | In Office Review |
| | | | | | | | | | | 04-27-2009 | JG | 03 | | 16 | In Office Review |
| | | | | | | | | | | 08-19-2008 | MK | 02 | | 02 | Bldg Permit Completed |

| LAND LINE VALUATION SECTION | | | | | | | | | | | | | | | | | |
|-----------------------------|----------|----------------|------|----|-----------------------|---------------|----------|------------------------|------------|-------|-------|-----------|-------|--------------------|------------|------------------|---------|
| B | Use Code | Description | Zone | LA | Land Units | Unit Price | Size Adj | AC Disc | Site Index | Cond. | Nbhd. | Nbhd. Adj | Notes | Location Adjustmen | Adj Unit P | Land Value | |
| 1 | 1010 | Single Fam M-0 | RF | 5 | 1.000 | AC 176,344.00 | 1.00000 | 1.0000 | 5 | 1.00 | 0108 | 1.700 | | 1.0000 | 299,784.8 | 299,800 | |
| 1 | 1010 | Single Fam M-0 | RF | 5 | 0.170 | AC 14,250.00 | 1.00000 | 1.0000 | 0 | 1.00 | 0108 | 1.700 | | 1.0000 | 24,225 | 4,100 | |
| | | | | | Total Card Land Units | 1.17 | AC | Parcel Total Land Area | | | | | 1.17 | | | Total Land Value | 303,900 |

| CONSTRUCTION DETAIL | | | CONSTRUCTION DETAIL (CONTINUED) | | |
|--------------------------|------|---------------|---------------------------------|-----|-------------|
| Element | Cd | Description | Element | Cd | Description |
| Style | 04 | Cape Cod | | | |
| Model | 01 | Residential | | | |
| Grade: | B- | Custom Minus | | | |
| Stories | 1.75 | 1 3/4 Stories | | | |
| Exterior Wall 1 | 11 | Clapboard | | | |
| Exterior Wall 2 | | | | | |
| Roof Structure | 03 | Gable/Hip | | | |
| Roof Cover | 10 | Wood Shingle | | | |
| Interior Wall 1 | 05 | Drywall | | | |
| Interior Wall 2 | | | | | |
| Interior Floor 1 | 14 | Carpet | | | |
| Interior Floor 2 | 12 | Hardwood | | | |
| Heat Fuel | 02 | Oil | | | |
| Heat Type | 05 | Hot Water | | | |
| AC Type | 03 | Central | | | |
| Bedrooms | 03 | 3 Bedrooms | | | |
| Full Baths | 2 | | | | |
| Half Baths | 0 | | | | |
| Extra Fixtures | | | | | |
| Total Rooms | 6 | 6 Rooms | | | |
| Bath Style | 02 | Average | | | |
| Kitchen Style | 02 | Modernized | | | |
| Occupancy | | | | | |
| Usrflid 105 | | | | | |
| Accessory Apt | | | | | |
| Foundation Alt | 01 | Poured Conc. | | | |
| Rms Prts | | | | | |
| Bath Split | 20 | 2 Full-0 Half | | | |
| CONDO DATA | | | COST / MARKET VALUATION | | |
| Parcel Id | | C | Ownr | 0.0 | |
| Adjust Type | Code | Description | Factor% | | |
| Condo Flr | | | | | |
| Condo Unit | | | | | |
| Building Value New | | 913,410 | | | |
| Year Built | | 1989 | | | |
| Effective Year Built | | 2005 | | | |
| Depreciation Code | | G | | | |
| Remodel Rating | | | | | |
| Year Remodeled | | | | | |
| Depreciation % | | 11 | | | |
| Functional Obsol | | 0 | | | |
| External Obsol | | 0 | | | |
| Trend Factor | | 1 | | | |
| Condition | | | | | |
| Condition % | | | | | |
| Percent Good | | 89 | | | |
| RCNLD | | 812,900 | | | |
| Dep % Ovr | | | | | |
| Dep Ovr Comment | | | | | |
| Misc Imp Ovr | | | | | |
| Misc Imp Ovr Comment | | | | | |
| Cost to Cure Ovr | | | | | |
| Cost to Cure Ovr Comment | | | | | |

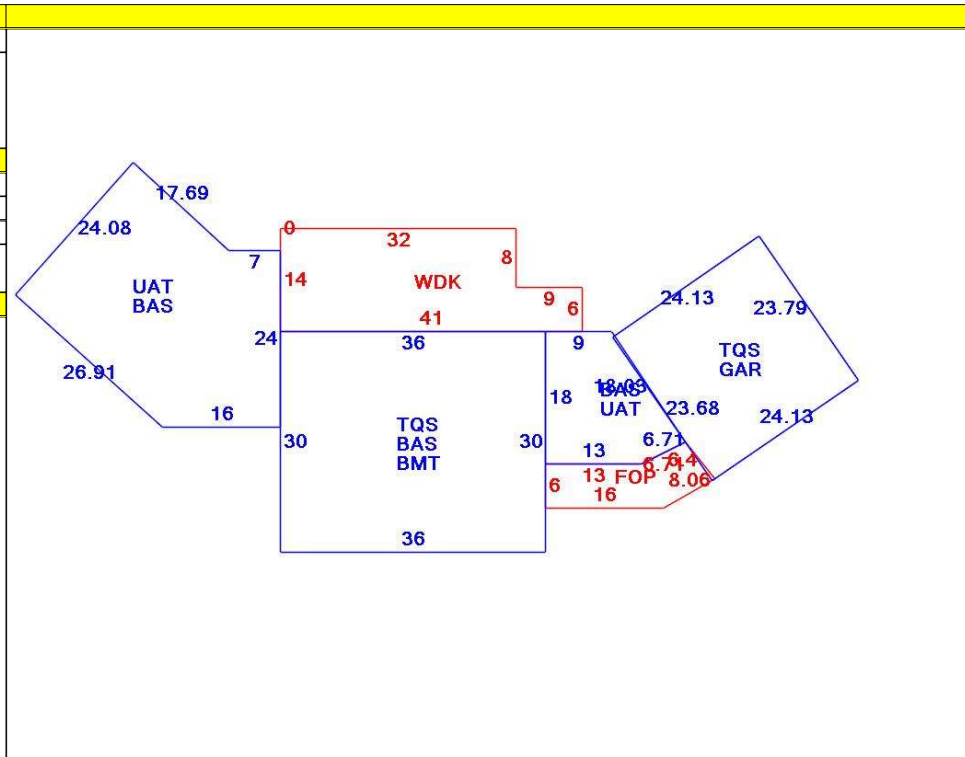

| OB - OUTBUILDING & YARD ITEMS(L) / XF - BUILDING EXTRA FEATURES(B) | | | | | | | | | | |
|--|-----------------|-----|-------|------------|--------|----------|------|-------|------------|-------------|
| Code | Description | L/B | Units | Unit Price | Yr Blt | Cond. Cd | % Gd | Grade | Grade Adj. | Appr. Value |
| FPL2 | Fireplace 1.5 s | B | 1 | 6000.00 | 2007 | | 89 | | 0.00 | 5,300 |
| WDC | Wood Decking | L | 502 | 20.00 | 2000 | | 62 | | 0.00 | 5,800 |
| FOP | Open Porch-ro | B | 135 | 55.00 | 2007 | | 89 | | 0.00 | 6,100 |
| GAR | Attached Gara | B | 576 | 40.00 | 2007 | | 89 | | 0.00 | 18,200 |
| BMT | Basement-Unfi | B | 1,080 | 26.01 | 2007 | | 89 | | 0.00 | 24,900 |

| BUILDING SUB-AREA SUMMARY SECTION | | | | | | |
|-----------------------------------|---------------------|-------------|------------|----------|-----------|----------------|
| Code | Description | Living Area | Floor Area | Eff Area | Unit Cost | Undeprec Value |
| BAS | First Floor | 2,148 | 2,148 | 2,148 | 274.38 | 589,367 |
| BMT | Basement Area | 0 | 1,080 | 0 | 0.00 | 0 |
| FOP | Open Porch | 0 | 135 | 0 | 0.00 | 0 |
| GAR | Attached Garage | 0 | 573 | 0 | 0.00 | 0 |
| TQS | Three Quarter Story | 1,074 | 1,653 | 1,074 | 178.27 | 294,684 |
| UAT | Attic, Unfinished | 0 | 1,068 | 107 | 27.49 | 29,359 |
| WDK | Wood Deck | 0 | 502 | 0 | 0.00 | 0 |
| Ttl Gross Liv / Lease Area | | 3,222 | 7,159 | 3,329 | | 913,410 |

