

| CURRENT OWNER   |  | TOPO    | UTILITIES               | STRT / ROAD | LOCATION                  | CURRENT ASSESSMENT |      |          |          | 801<br>FY2024<br>BARNSTABLE, MA |
|---|--|---------|-------------------------|-------------|---------------------------|--------------------|------|----------|----------|---------------------------------|
| OLMSTED, DODGE & MARILYN<br><br>23 WIANNO CIRCLE<br><br>OSTERVILLE MA 02655 |  | 1 Level | 2 Public Water          | 1 Paved     |                           | Description        | Code | Assessed | Assessed |                                 |
|   |  |         | 4 Gas                   |             |                           | RESIDENTL          | 1010 | 611,300  | 611,300  |                                 |
|   |  |         | 6 Septic                |             |                           | RES LAND           | 1010 | 959,200  | 959,200  |                                 |
| <b>SUPPLEMENTAL DATA</b>  |  |         |                         |             |                           |                    |      |          |          | <b>VISION</b>                   |
| Alt Prcl ID   |  |         | Plan Ref.               |             |                           |                    |      |          |          |                                 |
| Split Zonin RC;RF-1   |  |         | Land Ct# 2664-83 (SH 2) |             |                           |                    |      |          |          |                                 |
| ResExpt Q YES:  |  |         | Life Estate             |             |                           |                    |      |          |          |                                 |
| #DL 1 LOT 104   |  |         | PP STATU D:Deleted      |             |                           |                    |      |          |          |                                 |
| #DL 2   |  |         | Assoc Pid#              |             |                           |                    |      |          |          |                                 |
| GIS ID F_962927_2688521   |  |         |                         |             | Total 1,570,500 1,570,500 |                    |      |          |          |                                 |

| RECORD OF OWNERSHIP      |  | BK-VOL/PAGE | SALE DATE | Q/U        | V/I | SALE PRIC | VC        | PREVIOUS ASSESSMENTS (HISTORY) |       |      |           |       |      |          |
|--------------------------|--|-------------|-----------|------------|-----|-----------|-----------|--------------------------------|-------|------|-----------|-------|------|----------|
| OLMSTED, DODGE & MARILYN |  | C230922     | 0         | 08-30-2022 | Q   | I         | 1,700,000 | 00                             | Year  | Code | Assessed  | Year  | Code | Assessed |
| PHILLIPS, KAREN K        |  | C198490     | 0         | 10-22-2012 | Q   | I         | 729,239   | 00                             | 2023  | 1010 | 545,900   | 2022  | 1010 | 468,400  |
| COTTON, CHRISTINE S      |  | C127330     | 0         | 07-15-1992 | Q   | I         | 132,000   | U                              |       | 1010 | 858,100   |       | 1010 | 451,100  |
| GILMORE, ROBERT A TR     |  | C110471     | 0         | 04-15-1987 | U   | V         | 1         | B                              |       |      |           |       | 1010 | 43,900   |
| ROBERT, GILMORE ASSOC    |  | C74503      | 0         | 06-16-1978 | U   |           | 0         |                                | Total |      | 1,404,000 | Total |      | 919,500  |
|                          |  |             |           |            |     |           |           |                                | Total |      | 855,400   | Total |      |          |

| EXEMPTIONS |      |                       | OTHER ASSESSMENTS |      |             |        |        | This signature acknowledges a visit by a Data Collector or Assessor |  |  |  |  |
|------------|------|-----------------------|-------------------|------|-------------|--------|--------|---|--|--|--|--|
| Year       | Code | Description           | Amount            | Code | Description | Number | Amount | Comm Int  |  |  |  |  |
| 2024       | 5C   | RESIDENTIAL EXEMPTION |                   |      |             |        |        |   |  |  |  |  |
| Total      |      |                       | 0.00              |      |             |        |        |   |  |  |  |  |

| ASSESSING NEIGHBORHOOD |           |   |         | APPRAISED VALUE SUMMARY   |  |  |  |
|------------------------|-----------|---|---------|---|--|--|--|
| Nbhd                   | Nbhd Name | B | Tracing | Batch   |  |  |  |
| 0113                   |           |   |         | OSTVIL  |  |  |  |
| <b>NOTES</b>           |           |   |         | Appraised Bldg. Value (Card) 517,300<br>Appraised Xf (B) Value (Bldg) 50,100<br>Appraised Ob (B) Value (Bldg) 43,900<br>Appraised Land Value (Bldg) 959,200<br>Special Land Value 0<br>Total Appraised Parcel Value 1,570,500<br>Valuation Method C<br>Total Appraised Parcel Value 1,570,500 |  |  |  |

| BUILDING PERMIT RECORD |            |      |                  |         |            |        |            | VISIT / CHANGE HISTORY        |            |    |      |    |    |                       |
|------------------------|------------|------|------------------|---------|------------|--------|------------|-------------------------------|------------|----|------|----|----|-----------------------|
| Permit Id              | Issue Date | Type | Description      | Amount  | Insp Date  | % Comp | Date Comp  | Comments                      | Date       | Id | Type | Is | Cd | Purpost/Result        |
| BLDR-23-13             | 10-02-2023 | 880  | Alt-Int work-Res | 30,000  |            | 0      |            | Kitchen Renovation, replace c | 09-25-2023 | CK | 03   |    | 16 | In Office Review      |
| 16-393                 | 03-10-2016 | 809  | Deck             | 8,000   | 06-30-2016 | 100    | 06-30-2016 | remove old deck rebuild new   | 07-19-2023 | JO | 03   |    | 16 | In Office Review      |
| 201506276              | 10-02-2015 | SP   | Swimming Pool    | 80,000  | 06-30-2016 | 100    | 06-30-2016 | INGROUND 8X16 POOL WIT        | 06-03-2020 | WD |      |    | FR | Field Review          |
| 201206359              | 10-17-2012 | RE   | Remodel          | 1,500   | 06-30-2013 | 100    | 06-30-2013 | PARTITION WALL TO GREAT       | 09-11-2019 | CK | 22   |    | 22 | Change of Address     |
| 201005379              | 10-12-2010 | NR   | New Roof         | 9,275   | 06-30-2011 | 100    | 06-30-2011 | REROOF STRIPPING OLD          | 08-15-2019 | CK | 22   |    | 22 | Change of Address     |
| B35274                 | 08-01-1992 | DW   | Dwelling         | 160,000 | 01-15-1993 | 100    | 06-30-1993 | OS 11/2 S                     | 01-18-2018 | SR | 02   |    | 03 | Cycl Insp Comp        |
|                        |            |      |                  |         |            |        |            |                               | 06-27-2017 | SR | 02   |    | 02 | Bldg Permit Completed |

| LAND LINE VALUATION SECTION |          |                |      |    |            |            |                        |         |            |       |       |           |                  |                    |            |            |         |
|-----------------------------|----------|----------------|------|----|------------|------------|------------------------|---------|------------|-------|-------|-----------|------------------|--------------------|------------|------------|---------|
| B                           | Use Code | Description    | Zone | LA | Land Units | Unit Price | Size Adj               | AC Disc | Site Index | Cond. | Nbhd. | Nbhd. Adj | Notes            | Location Adjustmen | Adj Unit P | Land Value |         |
| 1                           | 1010     | Single Fam M-0 | SPLI | 3  | 0.350      | AC         | 176,344.00             | 2.46674 | 1.0000     | 5     | 1.00  | 0113      | 6.300            |                    | 1.0000     | 2,740,473  | 959,200 |
| Total Card Land Units       |          |                |      |    | 0.35       | AC         | Parcel Total Land Area |         |            |       |       | 0.35      | Total Land Value |                    |            | 959,200    |         |

| CONSTRUCTION DETAIL            |      |                | CONSTRUCTION DETAIL (CONTINUED) |     |             |
|--------------------------------|------|----------------|---------------------------------|-----|-------------|
| Element                        | Cd   | Description    | Element                         | Cd  | Description |
| Style                          | 04   | Cape Cod       |                                 |     |             |
| Model                          | 01   | Residential    |                                 |     |             |
| Grade:                         | C+   | Average Plus   |                                 |     |             |
| Stories                        | 1.75 | 1 3/4 Stories  |                                 |     |             |
| Exterior Wall 1                | 14   | Wood Shingle   |                                 |     |             |
| Exterior Wall 2                | 11   | Clapboard      |                                 |     |             |
| RooF Structure                 | 03   | Gable/Hip      |                                 |     |             |
| RooF Cover                     | 03   | Asph/F Gls/Cmp |                                 |     |             |
| Interior Wall 1                | 03   | Plastered      |                                 |     |             |
| Interior Wall 2                |      |                |                                 |     |             |
| Interior Floor 1               | 14   | Carpet         |                                 |     |             |
| Interior Floor 2               | 12   | Hardwood       |                                 |     |             |
| Heat Fuel                      | 03   | Gas            |                                 |     |             |
| Heat Type                      | 05   | Hot Water      |                                 |     |             |
| AC Type                        | 03   | Central        |                                 |     |             |
| Bedrooms                       | 03   | 3 Bedrooms     |                                 |     |             |
| Full Baths                     | 2    |                |                                 |     |             |
| Half Baths                     | 1    |                |                                 |     |             |
| Extra Fixtures                 |      |                |                                 |     |             |
| Total Rooms                    | 6    | 6 Rooms        |                                 |     |             |
| Bath Style                     |      |                |                                 |     |             |
| Kitchen Style                  |      |                |                                 |     |             |
| Occupancy                      |      |                |                                 |     |             |
| Usrflid 105                    |      |                |                                 |     |             |
| Accessory Apt                  |      |                |                                 |     |             |
| Foundation Alt                 | 01   | Poured Conc.   |                                 |     |             |
| Rms Prts                       |      |                |                                 |     |             |
| Bath Split                     | 21   | 2 Full-1 Half  |                                 |     |             |
| <b>CONDO DATA</b>              |      |                |                                 |     |             |
| Parcel Id                      |      | C              | Owne                            | 0.0 |             |
| Adjust Type                    | Code | Description    | Factor%                         |     |             |
| Condo Flr                      |      |                |                                 |     |             |
| Condo Unit                     |      |                |                                 |     |             |
| <b>COST / MARKET VALUATION</b> |      |                |                                 |     |             |
| Building Value New             |      | 594,620        |                                 |     |             |
| Year Built                     |      | 1992           |                                 |     |             |
| Effective Year Built           |      | 2002           |                                 |     |             |
| Depreciation Code              |      | A              |                                 |     |             |
| Remodel Rating                 |      |                |                                 |     |             |
| Year Remodeled                 |      |                |                                 |     |             |
| Depreciation %                 |      | 13             |                                 |     |             |
| Functional Obsol               |      | 0              |                                 |     |             |
| External Obsol                 |      | 0              |                                 |     |             |
| Trend Factor                   |      | 1              |                                 |     |             |
| Condition                      |      |                |                                 |     |             |
| Condition %                    |      |                |                                 |     |             |
| Percent Good                   |      | 87             |                                 |     |             |
| RCNLD                          |      | 517,300        |                                 |     |             |
| Dep % Ovr                      |      |                |                                 |     |             |
| Dep Ovr Comment                |      |                |                                 |     |             |
| Misc Imp Ovr                   |      |                |                                 |     |             |
| Misc Imp Ovr Comment           |      |                |                                 |     |             |
| Cost to Cure Ovr               |      |                |                                 |     |             |
| Cost to Cure Ovr Comment       |      |                |                                 |     |             |

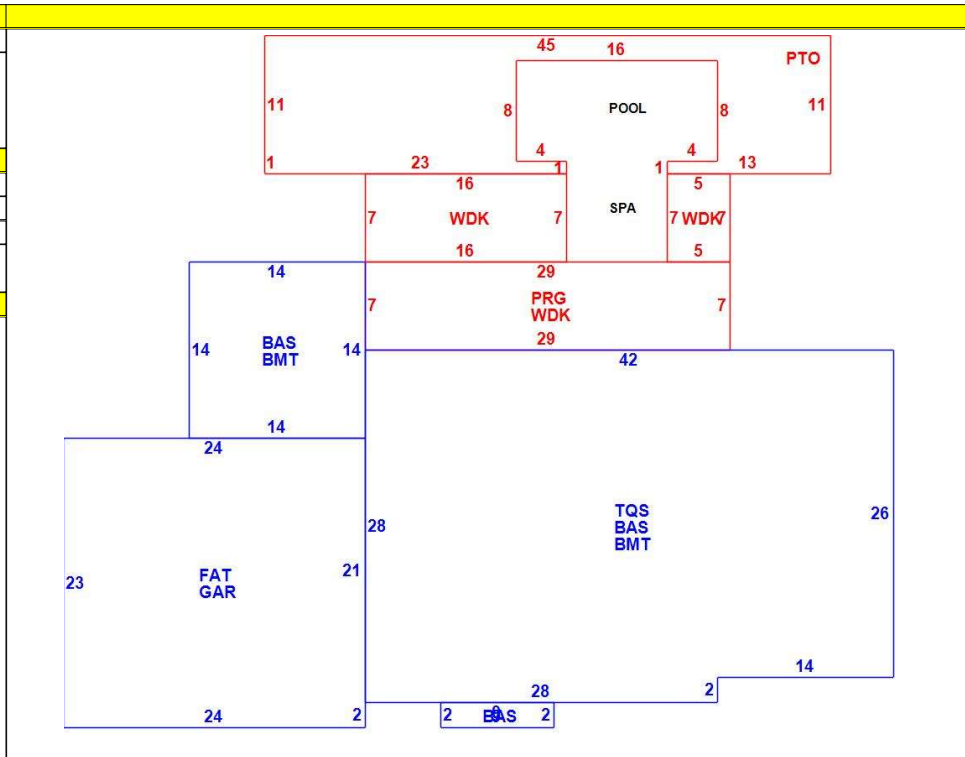

| OB - OUTBUILDING & YARD ITEMS(L) / XF - BUILDING EXTRA FEATURES(B) |                 |     |       |            |        |          |      |       |            |             |
|--|-----------------|-----|-------|------------|--------|----------|------|-------|------------|-------------|
| Code   | Description     | L/B | Units | Unit Price | Yr Blt | Cond. Cd | % Gd | Grade | Grade Adj. | Appr. Value |
| FPL1   | Fireplace 1 sto | B   | 1     | 5000.00    | 2004   |          | 87   |       | 0.00       | 4,400       |
| GAR  | Attached Gara   | B   | 552   | 40.00      | 2004   |          | 87   |       | 0.00       | 17,300      |
| BMT  | Basement-Unfi   | B   | 1,344 | 26.01      | 2004   |          | 87   |       | 0.00       | 28,400      |
| SPL3   | Pool Gunite     | L   | 128   | 75.00      | 2015   |          | 92   | 00    | 1.00       | 18,200      |
| JCZI   | Jacuzzi Outsid  | L   | 1     | 9822.00    | 2015   |          | 92   |       | 0.00       | 9,000       |
| PATC   | Conc Pavers     | L   | 359   | 15.46      | 2015   |          | 96   |       | 0.00       | 5,300       |
| WDC  | Wood Deck w/    | L   | 350   | 18.00      | 2016   |          | 94   |       | 0.00       | 5,800       |
| PRG1   | Pergola-Avg     | L   | 203   | 18.00      | 2016   |          | 94   | C     | 1.00       | 3,400       |
| SPH1   | Pool Heater <   | L   | 1     | 2434.00    | 2015   |          | 92   |       | 0.00       | 2,200       |

| BUILDING SUB-AREA SUMMARY SECTION |                     |             |            |          |           |                |
|-----------------------------------|---------------------|-------------|------------|----------|-----------|----------------|
| Code                              | Description         | Living Area | Floor Area | Eff Area | Unit Cost | Undeprec Value |
| BAS                               | First Floor         | 1,362       | 1,362      | 1,362    | 271.39    | 369,636        |
| BMT                               | Basement Area       | 0           | 1,344      | 0        | 0.00      | 0              |
| FAT                               | Attic, Finished     | 83          | 552        | 83       | 40.81     | 22,526         |
| GAR                               | Attached Garage     | 0           | 552        | 0        | 0.00      | 0              |
| PRG                               | Pergola             | 0           | 203        | 0        | 0.00      | 0              |
| PTO                               | Patio               | 0           | 359        | 0        | 0.00      | 0              |
| TQS                               | Three Quarter Story | 746         | 1,148      | 746      | 176.36    | 202,458        |
| WDK                               | Wood Deck           | 0           | 350        | 0        | 0.00      | 0              |
| Ttl Gross Liv / Lease Area        |                     | 2,191       | 5,870      | 2,191    |           | 594,620        |

