

CURRENT OWNER		TOPO	UTILITIES	STRT / ROAD	LOCATION	CURRENT ASSESSMENT				801 FY2024 BARNSTABLE, MA VISION	
CALLAHAN, DOROTHY ANN TR DOROTHY ANN CALLAHAN TRUST 1655 MIDDLE STREET SULLIVANS ISL SC 29482-8739		1 Level	2 Public Water	1 Paved		Description	Code	Assessed	Assessed		
			4 Gas			RESIDNTL	1010	269,300	269,300		
			6 Septic			RES LAND	1010	450,800	450,800		
SUPPLEMENTAL DATA						Total				720,100	720,100
Alt Prcl ID		Split Zonin		Plan Ref. 93/47							
#DL 1 LOT 9C		#DL 2 BLOCK D		Land Ct#							
GIS ID F_962119_2688674				#SR							
				Life Estate							
				PP STATU							
				Assoc Pid#							

RECORD OF OWNERSHIP		BK-VOL/PAGE	SALE DATE	Q/U	V/I	SALE PRIC	VC	PREVIOUS ASSESSMENTS (HISTORY)									
CALLAHAN, DOROTHY ANN TR		16149	0217	12-26-2002	U	I	1	1F	Year	Code	Assessed	Year	Code	Assessed			
CALLAHAN, DOROTHY M		1019	0489	10-17-1958	U		0		2023	1010	232,800	2022	1010	201,900			
										1010	530,800		1010	298,600			
													1010	13,100			
									Total		763,600	Total		500,500	Total		486,000

EXEMPTIONS			OTHER ASSESSMENTS					This signature acknowledges a visit by a Data Collector or Assessor						
Year	Code	Description	Amount	Code	Description	Number	Amount	Comm	Int					
Total			0.00											

ASSESSING NEIGHBORHOOD					APPRAISED VALUE SUMMARY					
Nbhd	Nbhd Name	B	Tracing	Batch	Appraised Bldg. Value (Card)					229,700
0111				OSTVIL	Appraised Xf (B) Value (Bldg)					26,500
					Appraised Ob (B) Value (Bldg)					13,100
					Appraised Land Value (Bldg)					450,800
					Special Land Value					0
					Total Appraised Parcel Value					720,100
					Valuation Method					C
					Total Appraised Parcel Value					720,100

BUILDING PERMIT RECORD								VISIT / CHANGE HISTORY							
Permit Id	Issue Date	Type	Description	Amount	Insp Date	% Comp	Date Comp	Comments	Date	Id	Type	Is	Cd	Purpost/Result	
20-2632	09-17-2020	822	Insulation	2,917		100		Insulation and air sealing work	06-02-2020	WD			FR	Field Review	
									10-03-2016	NF	03		16	In Office Review	
									09-23-2016	KM	02		03	Cycl Insp Comp	
									05-27-2010	DR	22		22	Change of Address	
									04-09-2007	PT	02		14	Cyclical Inspection	
									06-11-2004	PT	01		00	Meas/Listed-Interior Acces	
									04-30-2001	PT	01		00	Meas/Listed-Interior Acces	

LAND LINE VALUATION SECTION																	
B	Use Code	Description	Zone	LA	Land Units	Unit Price	Size Adj	AC Disc	Site Index	Cond.	Nbhd.	Nbhd. Adj	Notes	Location Adjustmen	Adj Unit P	Land Value	
1	1010	Single Fam M-0	RC	3	0.240	AC	176,344.00	3.49265	1.0000	5	1.00	0111	3.050		1.0000	1,878,522	450,800
Total Card Land Units					0.24	AC	Parcel Total Land Area					0.24	Total Land Value			450,800	

CONSTRUCTION DETAIL			CONSTRUCTION DETAIL (CONTINUED)		
Element	Cd	Description	Element	Cd	Description
Style	01	Ranch			
Model	01	Residential			
Grade:	C	Average			
Stories	1	1 Story			
Exterior Wall 1	14	Wood Shingle			
Exterior Wall 2					
RooF Structure	03	Gable/Hip			
RooF Cover	03	Asph/F Gls/Cmp			
Interior Wall 1	05	Drywall			
Interior Wall 2					
Interior Floor 1	12	Hardwood			
Interior Floor 2					
Heat Fuel	03	Gas			
Heat Type	05	Hot Water			
AC Type	01	None			
Bedrooms	03	3 Bedrooms			
Full Baths	1				
Half Baths	0				
Extra Fixtures					
Total Rooms	5	5 Rooms			
Bath Style					
Kitchen Style					
Occupancy					
Usrflid 105					
Accessory Apt					
Foundation Alt	02	Conc. Block			
Rms Prts					
Bath Split	10	1 Full-0 Half			

CONDO DATA				
Parcel Id		C	Ownr	0.0
			B	S
Adjust Type	Code	Description	Factor%	
Condo Flr				
Condo Unit				

COST / MARKET VALUATION		
Building Value New		310,430
Year Built		1959
Effective Year Built		1985
Depreciation Code		A
Remodel Rating		
Year Remodeled		
Depreciation %		26
Functional Obsol		0
External Obsol		0
Trend Factor		1
Condition		
Condition %		
Percent Good		74
RCNLD		229,700
Dep % Ovr		
Dep Ovr Comment		
Misc Imp Ovr		
Misc Imp Ovr Comment		
Cost to Cure Ovr		
Cost to Cure Ovr Comment		

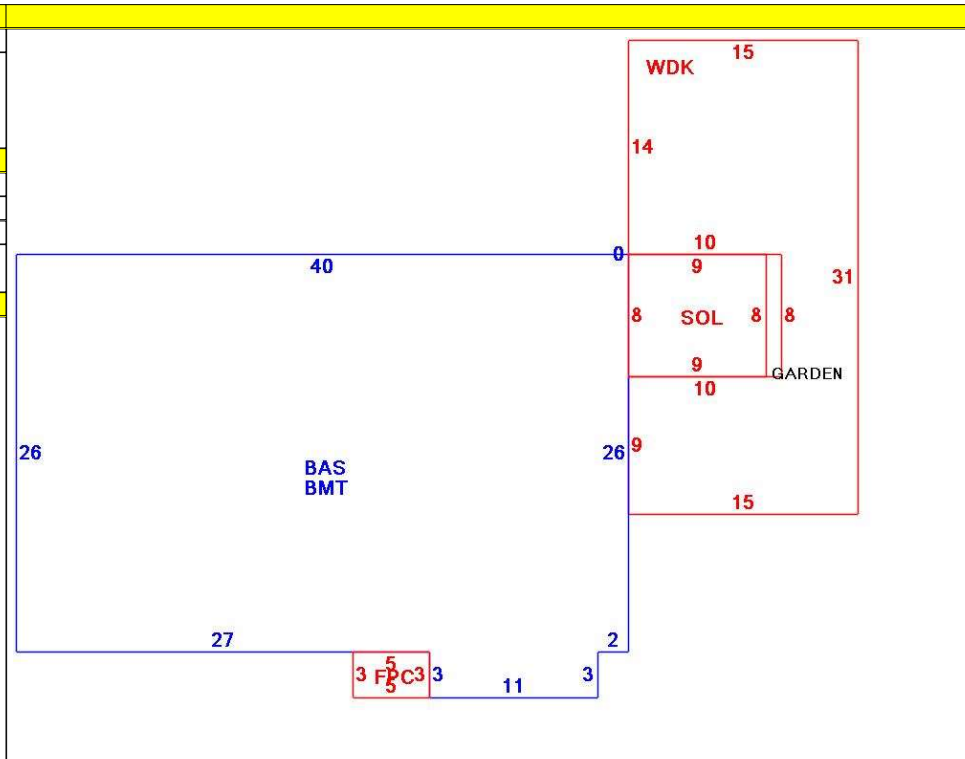

OB - OUTBUILDING & YARD ITEMS(L) / XF - BUILDING EXTRA FEATURES(B)										
Code	Description	L/B	Units	Unit Price	Yr Blt	Cond. Cd	% Gd	Grade	Grade Adj.	Appr. Value
FPL1	Fireplace 1 sto	B	1	5000.00	1987		74		0.00	3,700
BFA	Bsmt Fin-Avg	B	100	17.36	1987		74		0.00	1,300
SOL	Solarium	L	72	171.10	1993		74	C	1.00	10,300
FOPC	Open Prch-roo	B	15	55.00	1987		74		0.00	900
BMT	Basement-Unfi	B	1,073	26.01	1987		74		0.00	20,600
WDC	Wood Deck w/	L	385	18.00	1990		42		0.00	2,800

BUILDING SUB-AREA SUMMARY SECTION						
Code	Description	Living Area	Floor Area	Eff Area	Unit Cost	Undeprec Value
BAS	First Floor	1,073	1,073	1,073	289.31	310,430
BMT	Basement Area	0	1,073	0	0.00	0
FPC	Open Porch Conc. Floor	0	15	0	0.00	0
SOL	Solarium	0	72	0	0.00	0
WDC	Wood Deck	0	385	0	0.00	0
Ttl Gross Liv / Lease Area		1,073	2,618	1,073		310,430

