

| CURRENT OWNER   |  | TOPO    | UTILITIES      | STRT / ROAD   | LOCATION        | CURRENT ASSESSMENT |      |           |           | 801<br>FY2024<br>BARNSTABLE, MA<br><br><b>VISION</b> |           |
|---|--|---------|----------------|---|-----------------|--------------------|------|-----------|-----------|--|-----------|
| FULHAM, TIMOTHY W TRUSTEE<br>207 CRYSTAL LAKE ROAD TRUST<br>15 WINDSOR ROAD<br><br>WELLESLEY MA 02481 |  | 1 Level | 2 Public Water | 1 Paved   | 1 Lake/Pond Fro | Description        | Code | Assessed  | Assessed  |  |           |
|   |  |         | 4 Gas          |   |                 | RESIDNTL           | 1010 | 428,200   | 428,200   |  |           |
|   |  |         | 6 Septic       |   |                 | RES LAND           | 1010 | 2,135,900 | 2,135,900 |  |           |
| <b>SUPPLEMENTAL DATA</b>  |  |         |                |   |                 | Total              |      |           |           | 2,564,100  | 2,564,100 |
| Alt Prcl ID<br>Split Zonin<br>BID Parcel<br>ResExpt Q<br>#DL 1<br>#DL 2<br>GIS ID F_963989_2688234    |  |         |                | Plan Ref. 99/83<br>Land Ct#<br>#SR<br>Life Estate<br>PP STATU<br>Assoc Pid# |                 |                    |      |           |           |  |           |

| RECORD OF OWNERSHIP   |  | BK-VOL/PAGE | SALE DATE  | Q/U | V/I | SALE PRIC | VC | PREVIOUS ASSESSMENTS (HISTORY) |      |           |       |      |           |       |      |           |
|---|--|-------------|------------|-----|-----|-----------|----|--------------------------------|------|-----------|-------|------|-----------|-------|------|-----------|
| FULHAM, TIMOTHY W TRUSTEE<br>WELLS, DAVID Q TR<br>WELLS, JEAN KILEY TR<br>WELLS, JEAN K |  | 30835 0143  | 10-18-2017 | Q   | I   | 1,250,000 | 00 | Year                           | Code | Assessed  | Year  | Code | Assessed  | Year  | Code | Assessed  |
|   |  | 23945 0254  | 08-05-2009 | U   | I   | 0         | 1  | 2023                           | 1010 | 365,000   | 2022  | 1010 | 311,700   | 2021  | 1010 | 230,700   |
|   |  | 3380 0098   | 10-16-1981 | U   | I   | 1         | 1F |                                | 1010 | 1,941,700 |       | 1010 | 1,093,100 |       | 1010 | 1,064,300 |
|   |  | 0987 0417   | 10-29-1957 | U   |     | 0         |    | Total                          |      | 2,306,700 | Total |      | 1,404,800 | Total |      | 1,312,700 |

| EXEMPTIONS |      |             | OTHER ASSESSMENTS |      |             |        | This signature acknowledges a visit by a Data Collector or Assessor |          |  |  |  |  |  |  |  |
|------------|------|-------------|-------------------|------|-------------|--------|---|----------|--|--|--|--|--|--|--|
| Year       | Code | Description | Amount            | Code | Description | Number | Amount  | Comm Int |  |  |  |  |  |  |  |
|            |      |             |                   |      |             |        |   |          |  |  |  |  |  |  |  |
|            |      | Total       | 0.00              |      |             |        |   |          |  |  |  |  |  |  |  |

| ASSESSING NEIGHBORHOOD |           |   |         | APPRAISED VALUE SUMMARY |                               |           |  |
|------------------------|-----------|---|---------|-------------------------|-------------------------------|-----------|--|
| Nbhd                   | Nbhd Name | B | Tracing | Batch                   |                               |           |  |
| 0118                   |           |   |         | OSTVIL                  | Appraised Bldg. Value (Card)  | 397,400   |  |
|                        |           |   |         |                         | Appraised Xf (B) Value (Bldg) | 13,100    |  |
|                        |           |   |         |                         | Appraised Ob (B) Value (Bldg) | 17,700    |  |
|                        |           |   |         |                         | Appraised Land Value (Bldg)   | 2,135,900 |  |
|                        |           |   |         |                         | Special Land Value            | 0         |  |
|                        |           |   |         |                         | Total Appraised Parcel Value  | 2,564,100 |  |
|                        |           |   |         |                         | Valuation Method              | C         |  |
|                        |           |   |         |                         | Total Appraised Parcel Value  | 2,564,100 |  |

| NOTES |  |  |  |  |  |  |  |  |  | VISIT / CHANGE HISTORY |    |      |    |    |                            |
|-------|--|--|--|--|--|--|--|--|--|------------------------|----|------|----|----|----------------------------|
|       |  |  |  |  |  |  |  |  |  | Date                   | Id | Type | Is | Cd | Purpost/Result             |
|       |  |  |  |  |  |  |  |  |  | 06-03-2020             | WD |      |    | FR | Field Review               |
|       |  |  |  |  |  |  |  |  |  | 09-23-2016             | KM | 02   |    | 03 | Cycl Insp Comp             |
|       |  |  |  |  |  |  |  |  |  | 06-05-2009             | DR | 03   |    | 16 | In Office Review           |
|       |  |  |  |  |  |  |  |  |  | 04-06-2007             | PT | 02   |    | 14 | Cyclical Inspection        |
|       |  |  |  |  |  |  |  |  |  | 04-26-2001             | PT | 01   |    | 00 | Meas/Listed-Interior Acces |

| BUILDING PERMIT RECORD |            |      |             |        |           |        |           |          |  | LAND LINE VALUATION SECTION |    |      |    |    |                            |
|------------------------|------------|------|-------------|--------|-----------|--------|-----------|----------|--|-----------------------------|----|------|----|----|----------------------------|
| Permit Id              | Issue Date | Type | Description | Amount | Insp Date | % Comp | Date Comp | Comments |  | Date                        | Id | Type | Is | Cd | Purpost/Result             |
|                        |            |      |             |        |           |        |           |          |  | 06-03-2020                  | WD |      |    | FR | Field Review               |
|                        |            |      |             |        |           |        |           |          |  | 09-23-2016                  | KM | 02   |    | 03 | Cycl Insp Comp             |
|                        |            |      |             |        |           |        |           |          |  | 06-05-2009                  | DR | 03   |    | 16 | In Office Review           |
|                        |            |      |             |        |           |        |           |          |  | 04-06-2007                  | PT | 02   |    | 14 | Cyclical Inspection        |
|                        |            |      |             |        |           |        |           |          |  | 04-26-2001                  | PT | 01   |    | 00 | Meas/Listed-Interior Acces |

| B                     | Use Code | Description    | Zone | LA | Land Units | Unit Price | Size Adj               | AC Disc | Site Index | Cond. | Nbhd. | Nbhd. Adj | Notes            | Location Adjustmen | Adj Unit P | Land Value |           |
|-----------------------|----------|----------------|------|----|------------|------------|------------------------|---------|------------|-------|-------|-----------|------------------|--------------------|------------|------------|-----------|
| 1                     | 1010     | Single Fam M-0 | RF-1 | 3  | 0.720 AC   | 176,344.00 | 1.34577                | 1.0000  | 5          | 1.00  | 0118  | 12.500    | LAKE FRONT       |                    | 1.0000     | 2,966,494  | 2,135,900 |
| Total Card Land Units |          |                |      |    | 0.72       | AC         | Parcel Total Land Area |         |            |       |       | 0.72      | Total Land Value |                    |            | 2,135,900  |           |

| CONSTRUCTION DETAIL |    |                | CONSTRUCTION DETAIL (CONTINUED) |    |             |
|---------------------|----|----------------|---------------------------------|----|-------------|
| Element             | Cd | Description    | Element                         | Cd | Description |
| Style               | 01 | Ranch          |                                 |    |             |
| Model               | 01 | Residential    |                                 |    |             |
| Grade:              | C- | Average Minus  |                                 |    |             |
| Stories             | 1  | 1 Story        |                                 |    |             |
| Exterior Wall 1     | 11 | Clapboard      |                                 |    |             |
| Exterior Wall 2     |    |                |                                 |    |             |
| RooF Structure      | 03 | Gable/Hip      |                                 |    |             |
| RooF Cover          | 03 | Asph/F Gls/Cmp |                                 |    |             |
| Interior Wall 1     | 02 | Wall Brd/Wood  |                                 |    |             |
| Interior Wall 2     |    |                |                                 |    |             |
| Interior Floor 1    | 14 | Carpet         |                                 |    |             |
| Interior Floor 2    |    |                |                                 |    |             |
| Heat Fuel           | 01 | None           |                                 |    |             |
| Heat Type           | 01 | None           |                                 |    |             |
| AC Type             | 01 | None           |                                 |    |             |
| Bedrooms            | 06 | 6 Bedrooms     |                                 |    |             |
| Full Baths          | 2  |                |                                 |    |             |
| Half Baths          | 1  |                |                                 |    |             |
| Extra Fixtures      |    |                |                                 |    |             |
| Total Rooms         | 9  | 9 Rooms        |                                 |    |             |
| Bath Style          |    |                |                                 |    |             |
| Kitchen Style       |    |                |                                 |    |             |
| Occupancy           |    |                |                                 |    |             |
| Usrflid 105         |    |                |                                 |    |             |
| Accessory Apt       |    |                |                                 |    |             |
| Foundation Alt      | 06 | Piers          |                                 |    |             |
| Rms Prts            |    |                |                                 |    |             |
| Bath Split          | 21 | 2 Full-1 Half  |                                 |    |             |

| CONDO DATA  |      |             |         |     |
|-------------|------|-------------|---------|-----|
| Parcel Id   |      | C           | Owne    | 0.0 |
| Adjust Type | Code | Description | Factor% |     |
| Condo Flr   |      |             |         |     |
| Condo Unit  |      |             |         |     |

| COST / MARKET VALUATION  |  |         |
|--------------------------|--|---------|
| Building Value New       |  | 611,375 |
| Year Built               |  | 1920    |
| Effective Year Built     |  | 1974    |
| Depreciation Code        |  | F       |
| Remodel Rating           |  |         |
| Year Remodeled           |  |         |
| Depreciation %           |  | 35      |
| Functional Obsol         |  | 0       |
| External Obsol           |  | 0       |
| Trend Factor             |  | 1       |
| Condition                |  |         |
| Condition %              |  |         |
| Percent Good             |  | 65      |
| RCNLD                    |  | 397,400 |
| Dep % Ovr                |  |         |
| Dep Ovr Comment          |  |         |
| Misc Imp Ovr             |  |         |
| Misc Imp Ovr Comment     |  |         |
| Cost to Cure Ovr         |  |         |
| Cost to Cure Ovr Comment |  |         |

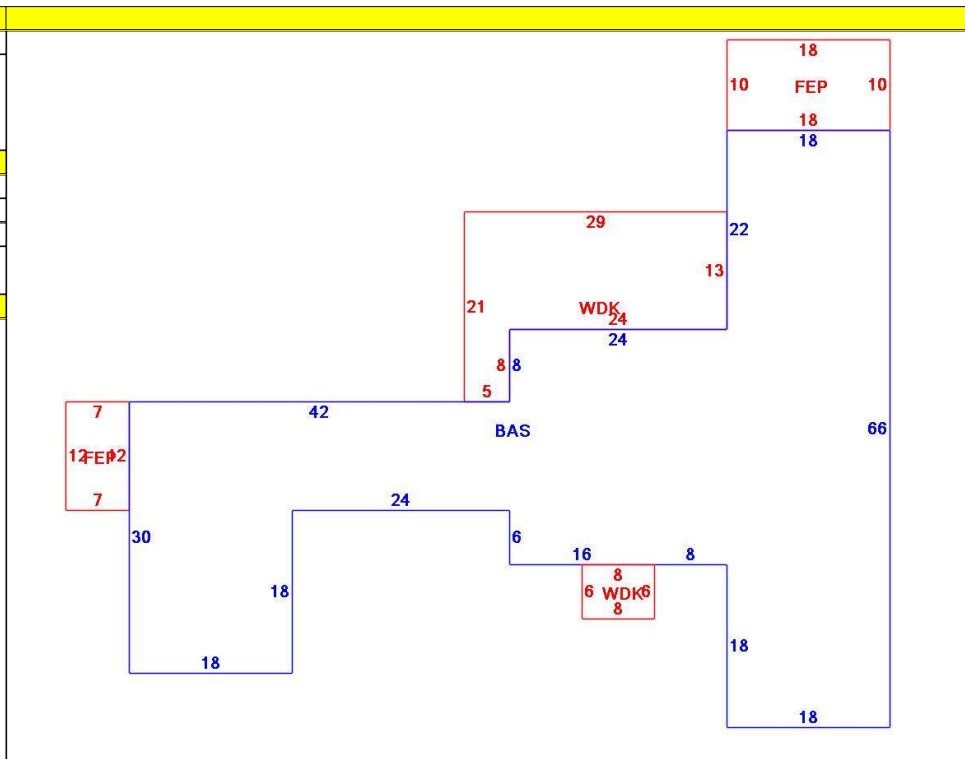

| OB - OUTBUILDING & YARD ITEMS(L) / XF - BUILDING EXTRA FEATURES(B) |                 |     |       |            |        |          |      |       |            |             |
|--|-----------------|-----|-------|------------|--------|----------|------|-------|------------|-------------|
| Code   | Description     | L/B | Units | Unit Price | Yr Blt | Cond. Cd | % Gd | Grade | Grade Adj. | Appr. Value |
| FPL1   | Fireplace 1 sto | B   | 1     | 5000.00    | 1974   |          | 65   |       | 0.00       | 3,300       |
| FGR2   | Garage- Avg-    | L   | 324   | 50.00      | 1920   |          | 1    | C     | 1.00       | 200         |
| DKPA   | Pond Dock-Av    | L   | 1     | 32500.00   | 1994   |          | 50   |       | 0.00       | 16,300      |
| WDC  | Wood Decking    | L   | 465   | 20.00      | 1976   |          | 14   |       | 0.00       | 1,200       |
| FEP  | Enclosed porc   | B   | 264   | 70.00      | 1974   |          | 65   |       | 0.00       | 9,800       |

| BUILDING SUB-AREA SUMMARY SECTION |                |             |            |          |           |                |
|-----------------------------------|----------------|-------------|------------|----------|-----------|----------------|
| Code                              | Description    | Living Area | Floor Area | Eff Area | Unit Cost | Undeprec Value |
| BAS                               | First Floor    | 2,640       | 2,640      | 2,640    | 231.58    | 611,375        |
| FEP                               | Enclosed Porch | 0           | 264        | 0        | 0.00      | 0              |
| WDK                               | Wood Deck      | 0           | 465        | 0        | 0.00      | 0              |
| Ttl Gross Liv / Lease Area        |                | 2,640       | 3,369      | 2,640    |           | 611,375        |

