

| CURRENT OWNER | | TOPO | UTILITIES | STRT / ROAD | LOCATION | CURRENT ASSESSMENT | | | | 801 FY2024 BARNSTABLE, MA VISION | |
|---|--|---------|----------------|---|----------|--------------------|------|----------|----------|--|-----------|
| EDWARDS, MYLES J & ALISON R 186 FOREST WAY ESSEX FIELDS NJ 07021 | | 1 Level | 2 Public Water | 1 Paved | | Description | Code | Assessed | Assessed | | |
| | | | 4 Gas | | | RESIDNTL | 1010 | 356,700 | 356,700 | | |
| | | | 6 Septic | | | RES LAND | 1010 | 819,400 | 819,400 | | |
| SUPPLEMENTAL DATA | | | | | | Total | | | | 1,176,100 | 1,176,100 |
| Alt Prcl ID Split Zonin BID Parcel ResExpt Q #DL 1 LOT 3A #DL 2 BLOCK B GIS ID F_962012_2689788 | | | | Plan Ref. 93/47 Land Ct# #SR Life Estate PP STATU Assoc Pid# | | | | | | | |

| RECORD OF OWNERSHIP | | BK-VOL/PAGE | SALE DATE | Q/U | V/I | SALE PRIC | VC | PREVIOUS ASSESSMENTS (HISTORY) | | | | | | | | |
|-----------------------------|-------|-------------|------------|------|----------|-----------|------|--------------------------------|-------|---------|----------|-------|---------|---------|------|---------|
| Year | Code | Assessed | Year | Code | Assessed | Year | Code | Assessed | Year | Code | Assessed | | | | | |
| EDWARDS, MYLES J & ALISON R | 25491 | 0282 | 06-06-2011 | Q | I | 440,000 | 00 | 2023 | 1010 | 310,700 | 2022 | 1010 | 267,700 | 2021 | 1010 | 210,300 |
| PRATT, BRIAN T & GINA M | 5446 | 0164 | 12-15-1986 | Q | I | 93,000 | U | | 1010 | 677,200 | | 1010 | 441,400 | | 1010 | 401,300 |
| MELCHIONO, PETER G | 4486 | 0307 | 04-15-1985 | Q | I | 83,000 | U | | | | | | | | | |
| AUSTIN, MICHAEL D & ELAINE | 1519 | 1046 | 07-20-1971 | U | | 0 | | | | | | | | | | |
| Total | | | | | | | | 987,900 | Total | | 709,100 | Total | | 618,000 | | |

| EXEMPTIONS | | | | OTHER ASSESSMENTS | | | | This signature acknowledges a visit by a Data Collector or Assessor | | | | |
|------------|------|-------------|--------|-------------------|-------------|--------|--------|---|--|--|--|--|
| Year | Code | Description | Amount | Code | Description | Number | Amount | Comm Int | | | | |
| Total | | | 0.00 | | | | | | | | | |

| ASSESSING NEIGHBORHOOD | | | | APPRAISED VALUE SUMMARY | | | | |
|------------------------|-----------|---|---------|-------------------------|-------------------------------|-----------|--|--|
| Nbhd | Nbhd Name | B | Tracing | Batch | | | | |
| 0112 | | | OSTVIL | | Appraised Bldg. Value (Card) | 316,200 | | |
| | | | | | Appraised Xf (B) Value (Bldg) | 34,100 | | |
| | | | | | Appraised Ob (B) Value (Bldg) | 6,400 | | |
| | | | | | Appraised Land Value (Bldg) | 819,400 | | |
| | | | | | Special Land Value | 0 | | |
| | | | | | Total Appraised Parcel Value | 1,176,100 | | |
| | | | | | Valuation Method | C | | |
| | | | | | Total Appraised Parcel Value | 1,176,100 | | |

| NOTES | | | | | | | | BUILDING PERMIT RECORD | | | | | | | | VISIT / CHANGE HISTORY | | | | | | | |
|-----------|------------|------|----------------|--------|------------|--------|------------|--------------------------------|------------|----|------|----|----|-------------------|--|------------------------|--|--|--|--|--|--|--|
| Permit Id | Issue Date | Type | Description | Amount | Insp Date | % Comp | Date Comp | Comments | Date | Id | Type | Is | Cd | Purpost/Result | | | | | | | | | |
| 17-2389 | 07-28-2017 | 835 | Sid/Wind/Roof/ | 14,900 | | 100 | | Remove existing shingle roof o | 06-02-2020 | WD | | | FR | Field Review | | | | | | | | | |
| 34162 | 10-19-1998 | AD | Addition | 8,000 | 04-18-1999 | 100 | 01-01-1998 | | 09-16-2016 | KM | 02 | | 03 | Cycl Insp Comp | | | | | | | | | |
| 11225 | 10-01-1995 | AD | Addition | 10,000 | 01-15-1996 | 100 | | OS GAR | 05-14-2012 | TP | 03 | | 16 | In Office Review | | | | | | | | | |
| B34280 | 04-01-1991 | AD | Addition | 12,000 | 01-15-1993 | 100 | | OS ADD'N | 02-14-2012 | NF | 02 | | 20 | Sale Review | | | | | | | | | |
| B30595 | 04-01-1987 | OB | Out Building | 1,500 | 01-15-1988 | 100 | | OS SHED | 02-06-2012 | JR | 03 | | 20 | Sale Review | | | | | | | | | |
| | | | | | | | | | 10-31-2011 | DR | 22 | | 22 | Change of Address | | | | | | | | | |
| | | | | | | | | | 10-25-2011 | DR | 03 | | 16 | In Office Review | | | | | | | | | |

| LAND LINE VALUATION SECTION | | | | | | | | | | | | | | | | | |
|-----------------------------|----------|----------------|------|----|------------|------------|------------------------|---------|------------|-------|-------|-----------|------------------|--------------------|------------|------------|---------|
| B | Use Code | Description | Zone | LA | Land Units | Unit Price | Size Adj | AC Disc | Site Index | Cond. | Nbhd. | Nbhd. Adj | Notes | Location Adjustmen | Adj Unit P | Land Value | |
| 1 | 1010 | Single Fam M-0 | RC | 3 | 0.250 | AC | 176,344.00 | 3.37919 | 1.0000 | 5 | 1.00 | 0112 | 5.500 | | 1.0000 | 3,277,441 | 819,400 |
| Total Card Land Units | | | | | 0.25 | AC | Parcel Total Land Area | | | | | 0.25 | Total Land Value | | | 819,400 | |

| CONSTRUCTION DETAIL | | | CONSTRUCTION DETAIL (CONTINUED) | | |
|---------------------|----|----------------|---------------------------------|------|-------------|
| Element | Cd | Description | Element | Cd | Description |
| Style | 01 | Ranch | | | |
| Model | 01 | Residential | | | |
| Grade: | C | Average | | | |
| Stories | 1 | 1 Story | | | |
| Exterior Wall 1 | 14 | Wood Shingle | | | |
| Exterior Wall 2 | 11 | Clapboard | | | |
| Roof Structure | 03 | Gable/Hip | | | |
| Roof Cover | 03 | Asph/F Gls/Cmp | | | |
| Interior Wall 1 | 05 | Drywall | | | |
| Interior Wall 2 | | | | | |
| Interior Floor 1 | 14 | Carpet | | | |
| Interior Floor 2 | 05 | Vinyl/Asphalt | | | |
| Heat Fuel | 03 | Gas | | | |
| Heat Type | 05 | Hot Water | | | |
| AC Type | 03 | Central | | | |
| Bedrooms | 03 | 3 Bedrooms | | | |
| Full Baths | 2 | | | | |
| Half Baths | 0 | | | | |
| Extra Fixtures | | | | | |
| Total Rooms | 6 | 6 Rooms | | | |
| Bath Style | | | | | |
| Kitchen Style | | | | | |
| Occupancy | | | | | |
| Usrflid 105 | | | | | |
| Accessory Apt | | | | | |
| Foundation Alt | 01 | Poured Conc. | | | |
| Rms Prts | | | | | |
| Bath Split | 20 | 2 Full-0 Half | | | |
| | | | CONDO DATA | | |
| | | | Parcel Id | C | Ownr 0.0 |
| | | | | B | S |
| | | | Adjust Type | Code | Description |
| | | | Condo Flr | | Factor% |
| | | | Condo Unit | | |
| | | | COST / MARKET VALUATION | | |
| | | | Building Value New | | 433,218 |
| | | | Year Built | | 1947 |
| | | | Effective Year Built | | 1984 |
| | | | Depreciation Code | | G |
| | | | Remodel Rating | | |
| | | | Year Remodeled | | |
| | | | Depreciation % | | 27 |
| | | | Functional Obsol | | 0 |
| | | | External Obsol | | 0 |
| | | | Trend Factor | | 1 |
| | | | Condition | | |
| | | | Condition % | | |
| | | | Percent Good | | 73 |
| | | | RCNLD | | 316,200 |
| | | | Dep % Ovr | | |
| | | | Dep Ovr Comment | | |
| | | | Misc Imp Ovr | | |
| | | | Misc Imp Ovr Comment | | |
| | | | Cost to Cure Ovr | | |
| | | | Cost to Cure Ovr Comment | | |

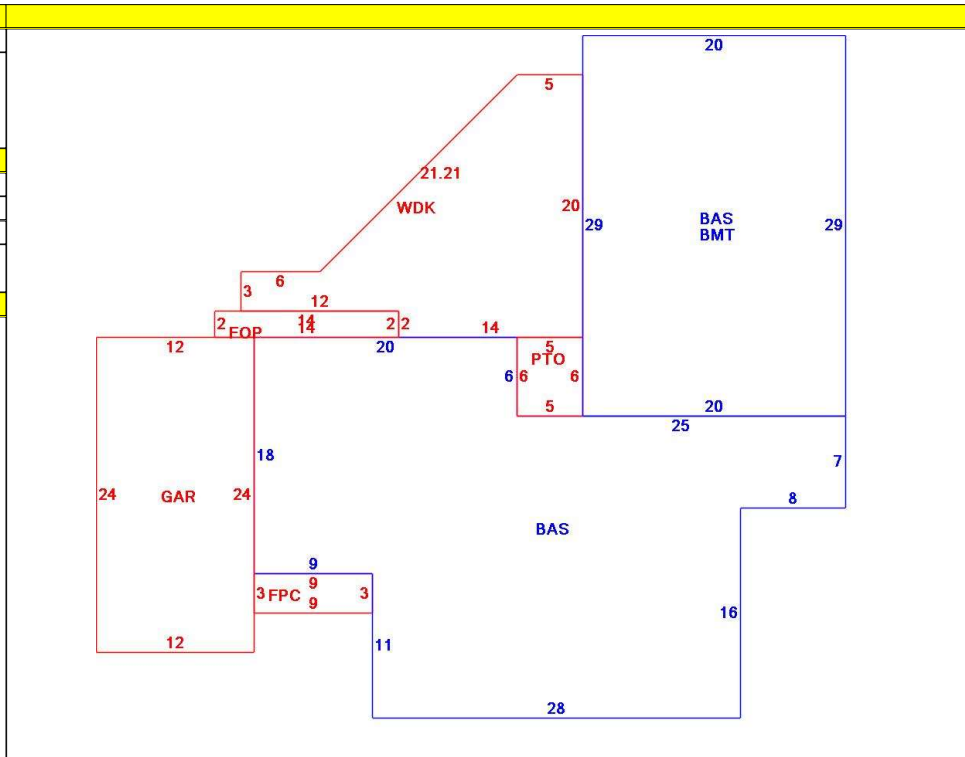

| OB - OUTBUILDING & YARD ITEMS(L) / XF - BUILDING EXTRA FEATURES(B) | | | | | | | | | | |
|--|-----------------|-----|-------|------------|--------|----------|------|-------|------------|-------------|
| Code | Description | L/B | Units | Unit Price | Yr Blt | Cond. Cd | % Gd | Grade | Grade Adj. | Appr. Value |
| FPL1 | Fireplace 1 sto | B | 1 | 5000.00 | 1986 | | 73 | | 0.00 | 3,700 |
| SHD2 | Shed w/Elec | L | 280 | 26.00 | 1975 | | 12 | | 0.00 | 900 |
| WDC | Wood Deck w/ | L | 294 | 18.00 | 1996 | | 54 | | 0.00 | 2,900 |
| GAR | Attached Gara | B | 288 | 40.00 | 1986 | | 73 | | 0.00 | 9,500 |
| BMT | Basement-Unfi | B | 580 | 26.01 | 1986 | | 73 | | 0.00 | 13,700 |
| FOPC | Open Prch-roo | B | 27 | 55.00 | 1986 | | 73 | | 0.00 | 1,300 |
| PAT1 | Patio- Average | L | 30 | 5.89 | 1996 | | 77 | | 0.00 | 200 |
| FOP | Open Porch-ro | B | 50 | 55.00 | 1986 | | 73 | | 0.00 | 2,400 |
| FOP | Open Porch-ro | B | 55 | 55.00 | 1986 | | 73 | | 0.00 | 2,600 |
| WDC | Wood Deck w/ | L | 50 | 18.00 | 2016 | | 94 | | 0.00 | 2,400 |

| BUILDING SUB-AREA SUMMARY SECTION | | | | | | |
|-----------------------------------|------------------------|-------------|------------|----------|-----------|----------------|
| Code | Description | Living Area | Floor Area | Eff Area | Unit Cost | Undeprec Value |
| BAS | First Floor | 1,508 | 1,508 | 1,508 | 287.28 | 433,218 |
| BMT | Basement Area | 0 | 580 | 0 | 0.00 | 0 |
| FOP | Open Porch | 0 | 28 | 0 | 0.00 | 0 |
| FPC | Open Porch Conc. Floor | 0 | 27 | 0 | 0.00 | 0 |
| GAR | Attached Garage | 0 | 288 | 0 | 0.00 | 0 |
| PTO | Patio | 0 | 30 | 0 | 0.00 | 0 |
| WDK | Wood Deck | 0 | 294 | 0 | 0.00 | 0 |
| Ttl Gross Liv / Lease Area | | 1,508 | 2,755 | 1,508 | | 433,218 |



| CURRENT OWNER | | TOPO | UTILITIES | STRT / ROAD | LOCATION | CURRENT ASSESSMENT | | | | 801 FY2024 BARNSTABLE, MA VISION | |
|--|--|-------------|----------------|-----------------|----------|--------------------|------|----------|----------|--|-----------|
| EDWARDS, MYLES J & ALISON R 186 FOREST WAY ESSEX FIELDS NJ 07021 | | 1 Level | 2 Public Water | 1 Paved | | Description | Code | Assessed | Assessed | | |
| | | | 4 Gas | | | RESIDNTL | 1010 | 356,700 | 356,700 | | |
| | | | 6 Septic | | | RES LAND | 1010 | 819,400 | 819,400 | | |
| SUPPLEMENTAL DATA | | | | | | Total | | | | 1,176,100 | 1,176,100 |
| Alt Prcl ID | | Split Zonin | | Plan Ref. 93/47 | | | | | | | |
| ESSEX FIELDS NJ 07021 | | BID Parcel | | Land Ct# | | | | | | | |
| ResExpt Q | | #SR | | Life Estate | | | | | | | |
| #DL 1 LOT 3A | | PP STATU | | Assoc Pid# | | | | | | | |
| #DL 2 BLOCK B | | | | | | | | | | | |
| GIS ID F_962012_2689788 | | | | | | | | | | | |

| RECORD OF OWNERSHIP | | BK-VOL/PAGE | SALE DATE | Q/U | V/I | SALE PRIC | VC | PREVIOUS ASSESSMENTS (HISTORY) | | | | | | | | |
|---------------------|--|-------------|-----------|-----|-----|-----------|----|--------------------------------|------|----------|-------|------|----------|-------|------|----------|
| | | | | | | | | Year | Code | Assessed | Year | Code | Assessed | Year | Code | Assessed |
| | | | | | | | | 2023 | 1010 | 310,700 | 2022 | 1010 | 267,700 | 2021 | 1010 | 210,300 |
| | | | | | | | | | 1010 | 677,200 | | 1010 | 441,400 | | 1010 | 401,300 |
| | | | | | | | | | | | | | | | 1010 | 6,400 |
| | | | | | | | | Total | | 987,900 | Total | | 709,100 | Total | | 618,000 |

| EXEMPTIONS | | | OTHER ASSESSMENTS | | | | This signature acknowledges a visit by a Data Collector or Assessor | | | | | |
|------------|------|-------------|-------------------|------|-------------|--------|---|----------|--|--|--|--|
| Year | Code | Description | Amount | Code | Description | Number | Amount | Comm Int | | | | |
| | | | | | | | | | | | | |
| Total | | | | | | | | | | | | |

| ASSESSING NEIGHBORHOOD | | | | APPRAISED VALUE SUMMARY | | | | |
|------------------------|-----------|---|---------|-------------------------------|--|--|--|-----------|
| Nbhd | Nbhd Name | B | Tracing | Batch | | | | |
| 0112 | | | | OSTVIL | | | | |
| NOTES | | | | Appraised Bldg. Value (Card) | | | | 316,200 |
| | | | | Appraised Xf (B) Value (Bldg) | | | | 34,100 |
| | | | | Appraised Ob (B) Value (Bldg) | | | | 6,400 |
| | | | | Appraised Land Value (Bldg) | | | | 819,400 |
| | | | | Special Land Value | | | | 0 |
| | | | | Total Appraised Parcel Value | | | | 1,176,100 |
| | | | | Valuation Method | | | | C |
| | | | | Total Appraised Parcel Value | | | | 1,176,100 |

| BUILDING PERMIT RECORD | | | | | | | | VISIT / CHANGE HISTORY | | | | | | |
|------------------------|------------|------|-------------|--------|-----------|--------|-----------|------------------------|------|----|------|----|----|----------------|
| Permit Id | Issue Date | Type | Description | Amount | Insp Date | % Comp | Date Comp | Comments | Date | Id | Type | Is | Cd | Purpost/Result |
| | | | | | | | | | | | | | | |

| LAND LINE VALUATION SECTION | | | | | | | | | | | | | | | | |
|-----------------------------|----------|-------------|------|----|------------------------|------------|----------|---------|------------|------------------|-------|-----------|-------|--------------------|------------|------------|
| B | Use Code | Description | Zone | LA | Land Units | Unit Price | Size Adj | AC Disc | Site Index | Cond. | Nbhd. | Nbhd. Adj | Notes | Location Adjustmen | Adj Unit P | Land Value |
| | | | | | | | | | | | | | | | | |
| Total Card Land Units | | | | | Parcel Total Land Area | | | | | Total Land Value | | | | | | |

| CONSTRUCTION DETAIL | | | | | CONSTRUCTION DETAIL (CONTINUED) | | | | | |
|---|------------------|----------------|------------|------------|---------------------------------|----------------|-------------|---------|------------|-------------|
| Element | Cd | Description | | | Element | Cd | Description | | | |
| Style | 01 | Ranch | | | | | | | | |
| Model | 01 | Residential | | | | | | | | |
| Grade: | C | Average | | | | | | | | |
| Stories | 1 | 1 Story | | | | | | | | |
| Exterior Wall 1 | 14 | Wood Shingle | | | CONDO DATA | | | | | |
| Exterior Wall 2 | 11 | Clapboard | | | Parcel Id | | C | | Ownr | 0.0 |
| Roof Structure | 03 | Gable/Hip | | | | | B | | S | |
| Roof Cover | 03 | Asph/F Gls/Cmp | | | Adjust Type | Code | Description | Factor% | | |
| Interior Wall 1 | 05 | Drywall | | | Condo Flr | | | | | |
| Interior Wall 2 | | | | | Condo Unit | | | | | |
| Interior Floor 1 | 14 | Carpet | | | COST / MARKET VALUATION | | | | | |
| Interior Floor 2 | 05 | Vinyl/Asphalt | | | Building Value New | | | | | |
| Heat Fuel | 03 | Gas | | | Year Built | | | | | |
| Heat Type | 05 | Hot Water | | | Effective Year Built | | | | | |
| AC Type | 03 | Central | | | Depreciation Code | | | | | |
| Bedrooms | 03 | 3 Bedrooms | | | Remodel Rating | | | | | |
| Full Baths | 2 | | | | Year Remodeled | | | | | |
| Half Baths | 0 | | | | Depreciation % | | | | | |
| Extra Fixtures | | | | | Functional Obsol | | | | | |
| Total Rooms | 6 | 6 Rooms | | | External Obsol | | | | | |
| Bath Style | | | | | Trend Factor | | | | | |
| Kitchen Style | | | | | Condition | | | | | |
| Occupancy | | | | | Condition % | | | | | |
| Usrflid 105 | | | | | Percent Good | | | | | |
| Accessory Apt | | | | | RCNLD | | | | | |
| Foundation Alt | 01 | Poured Conc. | | | Dep % Ovr | | | | | |
| Rms Prts | | | | | Dep Ovr Comment | | | | | |
| Bath Split | 20 | 2 Full-0 Half | | | Misc Imp Ovr | | | | | |
| | | | | | Misc Imp Ovr Comment | | | | | |
| | | | | | Cost to Cure Ovr | | | | | |
| | | | | | Cost to Cure Ovr Comment | | | | | |
| OB - OUTBUILDING & YARD ITEMS(L) / XF - BUILDING EXTRA FEATURES(B) | | | | | | | | | | |
| Code | Description | L/B | Units | Unit Price | Yr Blt | Cond. Cd | % Gd | Grade | Grade Adj. | Appr. Value |
| UST | Utility Storage- | B | 80 | 17.11 | 1986 | | 73 | | 0.00 | 900 |
| BUILDING SUB-AREA SUMMARY SECTION | | | | | | | | | | |
| Code | Description | Living Area | Floor Area | Eff Area | Unit Cost | Undeprec Value | | | | |
| | | | | | | | | | | |
| Ttl Gross Liv / Lease Area | | | | | | | | | | |