

CURRENT OWNER		TOPO	UTILITIES	STRT / ROAD	LOCATION	CURRENT ASSESSMENT			
SCIOLETTI, BRADLEY R & LAUREN A 248 NASHAWTUC RD CONCORD MA 01742		1 Level	2 Public Water	1 Paved		Description	Code	Assessed	Assessed
			4 Gas			RESIDNTL	1010	774,600	774,600
			6 Septic			RES LAND	1010	819,400	819,400
SUPPLEMENTAL DATA									
Alt Prcl ID		Split Zonin		Plan Ref. 93/47					
BID Parcel		ResExpt Q		Land Ct#					
#DL 1 LOT 12A		#DL 2		#SR					
GIS ID F_962227_2689108		Assoc Pid#		Life Estate					
				PP STATU					
						Total		1,594,000	1,594,000

801
 FY2024
 BARNSTABLE, MA

VISION

RECORD OF OWNERSHIP		BK-VOL/PAGE	SALE DATE	Q/U	V/I	SALE PRIC	VC	PREVIOUS ASSESSMENTS (HISTORY)					
SCIOLETTI, BRADLEY R & LAUREN A		29995 0263	10-11-2016	Q	I	820,000	00	Year	Code	Assessed	Year	Code	Assessed
STAVROS, CHRISTOPHER TR		24597 0216	06-04-2010	Q	I	750,000	00	2023	1010	598,900	2022	1010	557,000
HOLLINGSWORTH ROAD LLC		23219 0186	10-17-2008	U	I	1	1A		1010	677,200		1010	441,400
JENKINS, SUSAN FERRIMAN		23018 0221	07-01-2008	U	I	375,000	1					1010	3,400
HALL, IRWIN B		0763 0016	09-08-1950	Q		6,300	U						
Total								1,276,100	Total	998,400	Total	882,600	

EXEMPTIONS			OTHER ASSESSMENTS					
Year	Code	Description	Amount	Code	Description	Number	Amount	Comm Int
Total			0.00					

This signature acknowledges a visit by a Data Collector or Assessor

ASSESSING NEIGHBORHOOD				
Nbhd	Nbhd Name	B	Tracing	Batch
0112				OSTVIL

BUILDING PERMIT RECORD								VISIT / CHANGE HISTORY						
Permit Id	Issue Date	Type	Description	Amount	Insp Date	% Comp	Date Comp	Comments	Date	Id	Type	Is	Cd	Purpost/Result
200804098	08-19-2008	DW	Dwelling	322,500	07-17-2009	100	06-30-2009	4BDRM 2.5BTH W ATT GAR	06-03-2022	BM	22		22	Change of Address
200804097	08-19-2008	DE	Demolish	7,500	07-17-2009	100	06-30-2009	DEMO EXISTING	06-02-2020	WD			FR	Field Review
									07-17-2017	MD	22		22	Change of Address
									12-08-2016	AL	03		16	In Office Review
									09-16-2016	KM	02		03	Cycl Insp Comp
									12-15-2008	MK	02		52	New Construction
									11-04-2008	NF	03		20	Sale Review

LAND LINE VALUATION SECTION																
B	Use Code	Description	Zone	LA	Land Units	Unit Price	Size Adj	AC Disc	Site Index	Cond.	Nbhd.	Nbhd. Adj	Notes	Location Adjustmen	Adj Unit P	Land Value
1	1010	Single Fam M-0	RC	3	0.250 AC	176,344.00	3.37919	1.0000	5	1.00	0112	5.500		1.0000	3,277,441	819,400

Total Card Land Units 0.25 AC Parcel Total Land Area 0.25

Total Land Value 819,400

CONSTRUCTION DETAIL			CONSTRUCTION DETAIL (CONTINUED)		
Element	Cd	Description	Element	Cd	Description
Style	07	Modern/Contemp			
Model	01	Residential			
Grade:	B+	Custom Plus			
Stories	2	2 Stories			
Exterior Wall 1	14	Wood Shingle			
Exterior Wall 2					
Roof Structure	03	Gable/Hip			
Roof Cover	03	Asph/F Gls/Cmp			
Interior Wall 1	05	Drywall			
Interior Wall 2					
Interior Floor 1	12	Hardwood			
Interior Floor 2					
Heat Fuel	03	Gas			
Heat Type	04	Hot Air			
AC Type	03	Central			
Bedrooms	03	3 Bedrooms			
Full Baths	2				
Half Baths	1				
Extra Fixtures					
Total Rooms	8				
Bath Style					
Kitchen Style					
Occupancy					
Usrflid 105					
Accessory Apt					
Foundation Alt	01	Poured Conc.			
Rms Prts					
Bath Split	21	2 Full-1 Half			
			CONDO DATA		
			Parcel Id	C	Owne 0.0
				B	S
			Adjust Type	Code	Description
			Condo Flr		Factor%
			Condo Unit		
			COST / MARKET VALUATION		
			Building Value New		772,533
			Year Built		2008
			Effective Year Built		2010
			Depreciation Code		A
			Remodel Rating		
			Year Remodeled		
			Depreciation %		7
			Functional Obsol		0
			External Obsol		0
			Trend Factor		1
			Condition		
			Condition %		
			Percent Good		93
			RCNLD		718,500
			Dep % Ovr		
			Dep Ovr Comment		
			Misc Imp Ovr		
			Misc Imp Ovr Comment		
			Cost to Cure Ovr		
			Cost to Cure Ovr Comment		

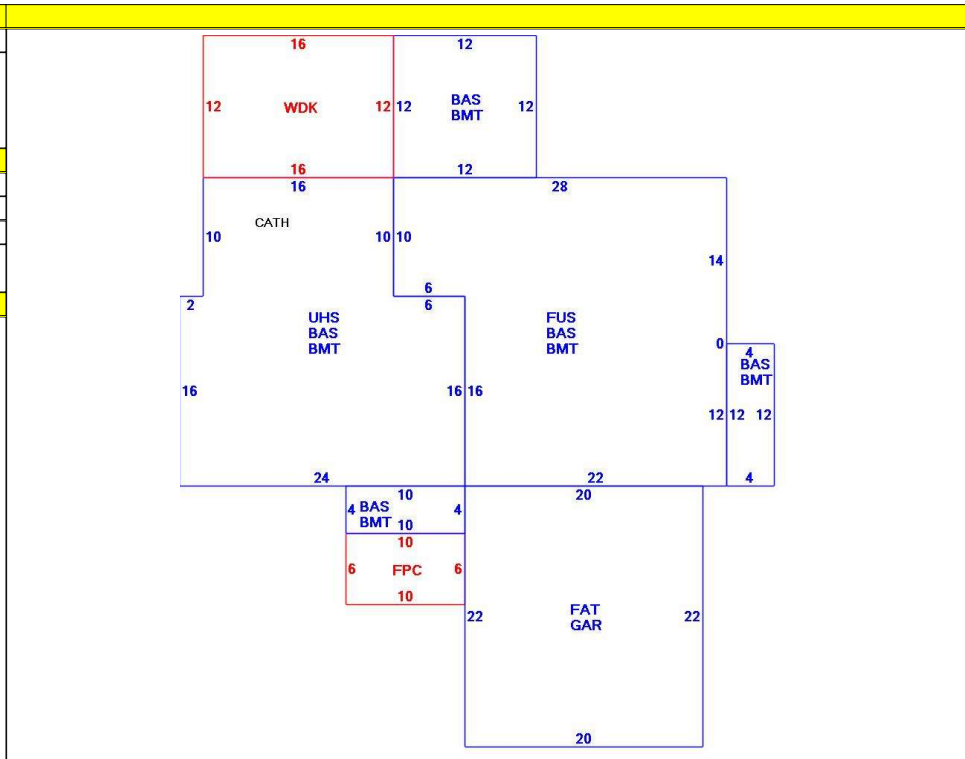

OB - OUTBUILDING & YARD ITEMS(L) / XF - BUILDING EXTRA FEATURES(B)										
Code	Description	L/B	Units	Unit Price	Yr Blt	Cond. Cd	% Gd	Grade	Grade Adj.	Appr. Value
FPLG	Gas Fireplace-	B	1	2500.00	2012		93		0.00	2,300
WDC	Wood Deck w/	L	192	18.00	2010		82		0.00	3,400
FOPC	Open Prch-roo	B	60	55.00	2012		93		0.00	3,000
GAR	Attached Gara	B	440	40.00	2012		93		0.00	15,900
BMT	Basement-Unfi	B	1,408	26.01	2012		93		0.00	31,500

BUILDING SUB-AREA SUMMARY SECTION						
Code	Description	Living Area	Floor Area	Eff Area	Unit Cost	Undeprec Value
BAS	First Floor	1,408	1,408	1,408	340.47	479,386
BMT	Basement Area	0	1,408	0	0.00	0
FAT	Attic, Finished	66	440	66	51.07	22,471
FPC	Open Porch Conc. Floor	0	60	0	0.00	0
FUS	Upper Story	632	632	632	340.47	215,179
GAR	Attached Garage	0	440	0	0.00	0
UHS	Half Story, Unfinished	0	544	163	102.02	55,497
WDK	Wood Deck	0	192	0	0.00	0
Ttl Gross Liv / Lease Area		2,106	5,124	2,269		772,533

