

CONSTRUCTION DETAIL			CONSTRUCTION DETAIL (CONTINUED)		
Element	Cd	Description	Element	Cd	Description
Style	03	Colonial			
Model	01	Residential			
Grade:	C+	Average Plus			
Stories	2.4				
Exterior Wall 1	14	Wood Shingle			
Exterior Wall 2					
Roof Structure	03	Gable/Hip			
Roof Cover	03	Asph/F Gls/Cmp			
Interior Wall 1	03	Plastered			
Interior Wall 2					
Interior Floor 1	12	Hardwood			
Interior Floor 2	14	Carpet			
Heat Fuel	02	Oil			
Heat Type	05	Hot Water			
AC Type	01	None			
Bedrooms	06	6 Bedrooms			
Full Baths	2				
Half Baths	2				
Extra Fixtures					
Total Rooms	11				
Bath Style					
Kitchen Style					
Occupancy					
Usrflid 105					
Accessory Apt					
Foundation Alt	08	Mixed			
Rms Prts					
Bath Split	22	2 Full-2 Half			

CONDO DATA				
Parcel Id		C		Owne 0.0
			B	S
Adjust Type	Code	Description	Factor%	
Condo Flr				
Condo Unit				

COST / MARKET VALUATION	
Building Value New	683,819
Year Built	1926
Effective Year Built	1979
Depreciation Code	A
Remodel Rating	
Year Remodeled	
Depreciation %	31
Functional Obsol	0
External Obsol	0
Trend Factor	1
Condition	
Condition %	
Percent Good	69
RCNLD	471,800
Dep % Ovr	
Dep Ovr Comment	
Misc Imp Ovr	
Misc Imp Ovr Comment	
Cost to Cure Ovr	
Cost to Cure Ovr Comment	

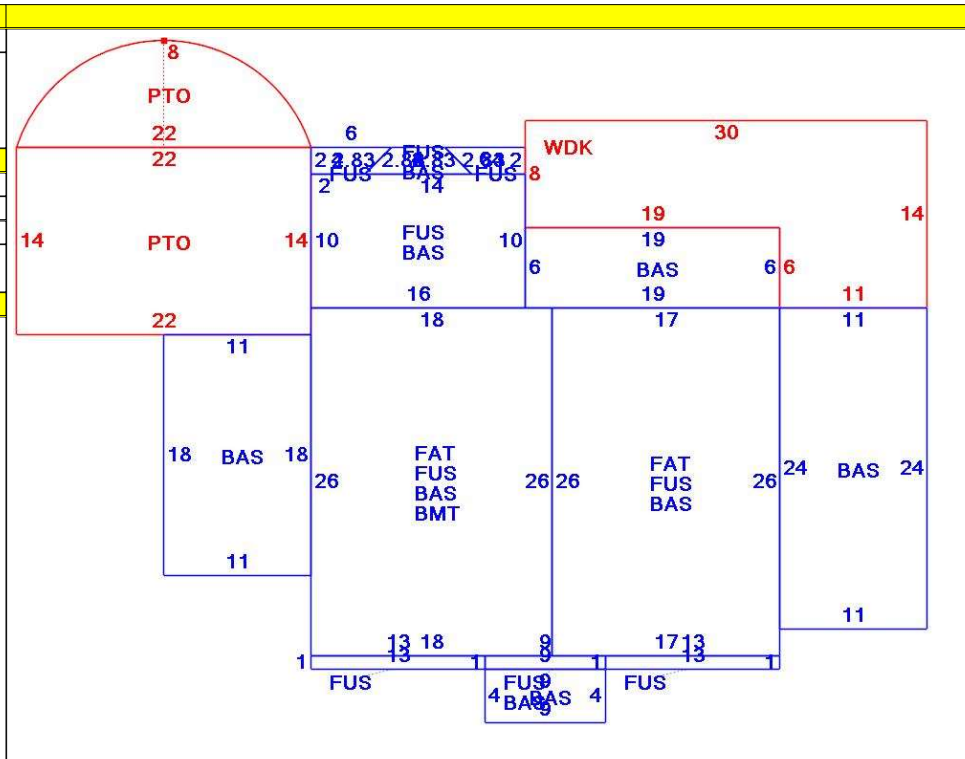

OB - OUTBUILDING & YARD ITEMS(L) / XF - BUILDING EXTRA FEATURES(B)

Code	Description	L/B	Units	Unit Price	Yr Blt	Cond. Cd	% Gd	Grade	Grade Adj.	Appr. Value
FPL3	Fireplace 2 sto	B	1	7000.00	1979		69		0.00	4,800
FGR2	Garage- Avg-	L	632	50.00	1975		56	00	1.00	17,700
WDC	Deck comp w	L	306	28.00	1986		34		0.00	2,900
PAT2	Patio-Good	L	437	9.94	1986		67		0.00	2,900
BMT	Basement-Unfi	B	468	26.01	1979		69		0.00	11,100
FPL1	Fireplace 1 sto	B	1	5000.00	1979		69		0.00	3,500

BUILDING SUB-AREA SUMMARY SECTION

Code	Description	Living Area	Floor Area	Eff Area	Unit Cost	Undeprec Value
BAS	First Floor	1,703	1,703	1,703	229.41	390,677
BMT	Basement Area	0	468	0	0.00	0
FAT	Attic, Finished	137	910	137	34.54	31,428
FUS	Upper Story	1,137	1,137	1,137	229.41	260,833
PTO	Patio	0	437	0	0.00	0
WDK	Wood Deck	0	306	0	0.00	0
Ttl Gross Liv / Lease Area		2,977	4,961	2,977		682,938

