

CURRENT OWNER		TOPO	UTILITIES	STRT / ROAD	LOCATION	CURRENT ASSESSMENT												
DUNNING, MICHAEL A & ELIZABETH WKC REALTY TRUST PO BOX 841  BARNSTABLE MA 02630						Description	Code	Assessed	Assessed	801  FY2024 BARNSTABLE, MA  <h1 style="text-align: center;">VISION</h1>								
						RESIDNTL	1020	581,900	581,900									
SUPPLEMENTAL DATA						Total												
Alt Prcl ID Split Zonin RC;BA BID Parcel ResExpt Q #DL 1 UNIT E3 #DL 2 BLDG E GIS ID F_961840_2691249				Plan Ref. 363/88-95 Land Ct# #SR Life Estate PP STATU A:Active  Assoc Pid#		581,900		581,900										
RECORD OF OWNERSHIP		BK-VOL/PAGE	SALE DATE	Q/U	V/I	SALE PRICE	VC	PREVIOUS ASSESSMENTS (HISTORY)										
DUNNING, MICHAEL A & ELIZABETH M TRS		31633 0091	10-31-2018	U	I	186,000	1F	Year	Code	Assessed	Year	Code	Assessed					
DUNNING, MICHAEL A		25438 0100	05-10-2011	U	I	1	1F	2023	1020	530,100	2022	1020	354,600					
HOLLY, LOUISE H & MARK H		25438 0094	05-10-2011	U	I	15,000	1A											
HOLLY, LOUISE H & MARK H		22985 0294	06-17-2008	U	I	145,000	00											
HOLLY, LOUISE H		11246 0114	02-26-1998	Q	I			Total		530,100	Total		354,600					
								Total			Total		357,900					
EXEMPTIONS			OTHER ASSESSMENTS				This signature acknowledges a visit by a Data Collector or Assessor											
Year	Code	Description	Amount	Code	Description	Number	Amount	Comm Int										
			0.00															
ASSESSING NEIGHBORHOOD																		
Nbhd		Nbhd Name		B		Tracing		Batch										
0001								OSTVIL										
NOTES																		
BUILDING PERMIT RECORD																		
Permit Id	Issue Date	Type	Description	Amount	Insp Date	% Comp	Date Comp	Comments	Date	Id	Type	Is	Cd	Purpost/Result				
									06-03-2020	WD			FR	Field Review				
									05-20-2019	SR	02		03	Cycl Insp Comp				
									07-29-2015	TP	03		16	In Office Review				
									08-22-2014	TP	03		16	In Office Review				
LAND LINE VALUATION SECTION																		
B	Use Code	Description	Zone	Dist	Land Type	Land Units	Unit Price	Size Adj	Site Index	Cond.	Nbhd.	Nbhd. Adj	Notes	Location Adjustmen	Adj Unit P	Land Value		
1	102U	Condominium M	SPLI	3		0 SF	0.00	1.00000	5	1.00	0001	1.000		0.0000	0	0		
Total Card Land Units						0 SF	Parcel Total Land Area						0.00	Total Land Value				0

CONSTRUCTION DETAIL			CONSTRUCTION DETAIL (CONTINUED)		
Element	Cd	Description	Element	Cd	Description
Style	55	Condominium			
Model	05	Res Condo			
Bedrm Func	C+	Average Plus			
Stories	1	1 Story			
Occupancy	0				
Interior Wall 1	05	Drywall			
Interior Wall 2					
Interior Floor 1	14	Carpet			
Interior Floor 2					
Heat Fuel	04	Electric			
Heat Type	07	Elec Baseboard			
AC Type	03	Central			
Bedrooms	02	2 Bedrooms			
Full Baths	2	2 Full			
Half Baths	0				
Extra Fixtures					
Total Rooms	5	5 Rooms			
Bath Style					
Kitchen Style					
Master Deed L	1295				
Bath Split	20	2 Full-0 Half			
Foundation	01	Poured Conc.			
AC Type Alt					
Sewer Occupan					
CONDO DATA					
Parcel Id	104194	C 0030	Owne	3.7	
	WIANNO KNOLL	B 1	S 1		
Adjust Type	Code	Description	Factor%		
Condo Flr			100		
Condo Unit	MKT0	MKT0	100		
COST / MARKET VALUATION					
Building Value New		656,347			
Year Built		1983			
Effective Year Built		2001			
Depreciation Code		A			
Remodel Rating					
Year Remodeled		14			
Depreciation %		0			
Functional Obsol		0			
External Obsol		0			
Trend Factor		1			
Condition					
Condition %		86			
Percent Good		564,500			
Cns Sect Rcnd					
Dep % Ovr					
Dep Ovr Comment					
Misc Imp Ovr					
Misc Imp Ovr Comment					
Cost to Cure Ovr					
Cost to Cure Ovr Comment					

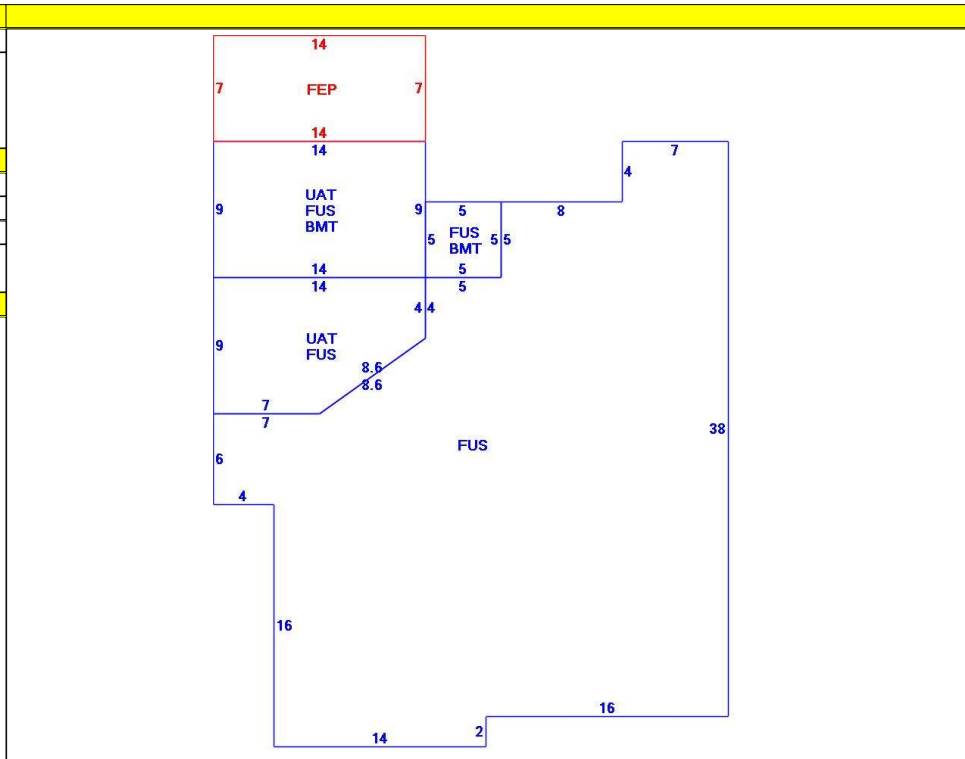

OB - OUTBUILDING & YARD ITEMS(L) / XF - BUILDING EXTRA FEATURES(B)										
Code	Description	L/B	Units	Unit Price	Yr Blt	Cond. Cd	% Gd	Grade	Grade Adj.	Appr. Value
FEP	Enclosed porc	B	98	70.00	2003		86		0.00	7,000
FPL1	Fireplace 1 sto	B	1	5000.00	2003		86		0.00	4,300
BMT	Basement-Unfi	B	151	26.01	2003		86		0.00	6,100

BUILDING SUB-AREA SUMMARY SECTION						
Code	Description	Living Area	Floor Area	Eff Area	Unit Cost	Undeprec Value
BMT	Basement Area	0	151	0	0.00	0
FEP	Enclosed Porch	0	98	0	0.00	0
FUS	Upper Story	1,213	1,213	1,213	530.60	643,612
UAT	Attic, Unfinished	0	235	24	54.19	12,734
Ttl Gross Liv / Lease Area		1,213	1,697	1,237		656,346

