

| CURRENT OWNER | | TOPO | UTILITIES | STRT / ROAD | LOCATION | CURRENT ASSESSMENT | | | | | | 801 FY2024 BARNSTABLE, MA | | | | | | |
|--|------------|--------------------------|---------------------|-------------|-------------|--------------------|---|--------------------------------|------------|----------|-------|---------------------------------|------------|--------------------|------------|------------|--|---|
| TALANIAN, MIRIAM T TR TALANIAN FAMILY REALTY TRUST PO BOX 3456 WAQUOIT MA 02536 | | | | | | Description | Code | Assessed | Assessed | | | | | | | | | |
| | | | | | | RESIDNTL | 1020 | 649,500 | 649,500 | | | | | | | | | |
| SUPPLEMENTAL DATA | | | | | | | | | | | | | | | | | | |
| Alt Prcl ID | | | Plan Ref. 363/88-95 | | | | | | | | | | | | | | | |
| Split Zonin RC;BA | | | Land Ct# | | | | | | | | | | | | | | | |
| BID Parcel | | | #SR | | | | | | | | | | | | | | | |
| ResExpt Q NO APP: | | | Life Estate | | | | | | | | | | | | | | | |
| #DL 1 UNIT G3 | | | PP STATU | | | | | | | | | | | | | | | |
| #DL 2 BLDG G | | | | | | | | | | | | | | | | | | |
| GIS ID F_961840_2691249 | | | Assoc Pid# | | | | | | | | | | | | | | | |
| | | | | | | Total | | 649,500 | 649,500 | | | | | | | | | |
| RECORD OF OWNERSHIP | | BK-VOL/PAGE | SALE DATE | Q/U | V/I | SALE PRICE | VC | PREVIOUS ASSESSMENTS (HISTORY) | | | | | | | | | | |
| TALANIAN, MIRIAM T TR | | 34035 287 | 09-02-2019 | U | I | 0 | 1F | Year | Code | Assessed | Year | Code | Assessed V | Year | Code | Assessed | | |
| TALANIAN, B ROBERT & MIRIAM T TRS | | 31152 0314 | 03-23-2018 | Q | I | 275,925 | 00 | 2023 | 1020 | 591,000 | 2022 | 1020 | 392,700 | 2021 | 1020 | 397,100 | | |
| LALIBERTE, NICOLE | | 28147 0169 | 05-16-2014 | Q | I | 244,500 | 00 | | | | | | | | | | | |
| MACALLISTER, PHILIP C | | 26588 0321 | 08-15-2012 | Q | I | 210,000 | 00 | | | | | | | | | | | |
| GIBSON, RUTH M | | 9819 0179 | 08-15-1995 | Q | I | 130,000 | U | | | | | | | | | | | |
| | | | | | | Total | | 591,000 | Total | 392,700 | Total | | 397,100 | | | | | |
| EXEMPTIONS | | | OTHER ASSESSMENTS | | | | This signature acknowledges a visit by a Data Collector or Assessor | | | | | | | | | | | |
| Year | Code | Description | Amount | Code | Description | Number | Amount | Comm Int | | | | | | | | | | |
| 2020 | N5C | NO RESIDENTIAL EXEMPTION | 0.00 | | | | | | | | | | | | | | | |
| Total | | | 0.00 | | | | | | | | | | | | | | | |
| ASSESSING NEIGHBORHOOD | | | | | | | | | | | | | | | | | | |
| Nbhd | | Nbhd Name | | B | | Tracing | | Batch | | | | | | | | | | |
| 0001 | | | | | | | | OSTVIL | | | | | | | | | | |
| NOTES | | | | | | | | | | | | | | | | | | |
| | | | | | | | | | | | | | | | | | | |
| BUILDING PERMIT RECORD | | | | | | | | VISIT / CHANGE HISTORY | | | | | | | | | | |
| Permit Id | Issue Date | Type | Description | Amount | Insp Date | % Comp | Date Comp | Comments | Date | Id | Type | Is | Cd | Purpost/Result | | | | |
| | | | | | | | | | 06-03-2020 | WD | | | FR | Field Review | | | | |
| | | | | | | | | | 05-20-2019 | SR | 02 | | 03 | Cycl Insp Comp | | | | |
| | | | | | | | | | 10-08-2015 | TR | 22 | | 22 | Change of Address | | | | |
| | | | | | | | | | 10-07-2015 | GC | 03 | | 16 | In Office Review | | | | |
| | | | | | | | | | 07-29-2015 | TP | 03 | | 16 | In Office Review | | | | |
| | | | | | | | | | 08-22-2014 | TP | 03 | | 16 | In Office Review | | | | |
| | | | | | | | | | 06-14-2013 | TP | 03 | | 16 | In Office Review | | | | |
| LAND LINE VALUATION SECTION | | | | | | | | | | | | | | | | | | |
| B | Use Code | Description | Zone | Dist | Land Type | Land Units | Unit Price | Size Adj | Site Index | Cond. | Nbhd. | Nbhd. Adj | Notes | Location Adjustmen | Adj Unit P | Land Value | | |
| 1 | 102U | Condominium M | SPLI | 3 | | 0 SF | 0.00 | 1.00000 | 5 | 1.00 | 0001 | 1.000 | | 0.0000 | 0 | 0 | | |
| Total Card Land Units | | | | | | 0 SF | Parcel Total Land Area | | | | | | 0.00 | Total Land Value | | | | 0 |

VISION

| CONSTRUCTION DETAIL | | | CONSTRUCTION DETAIL (CONTINUED) | | |
|--------------------------------|--------------|----------------|---------------------------------|-----|-------------|
| Element | Cd | Description | Element | Cd | Description |
| Style | 55 | Condominium | | | |
| Model | 05 | Res Condo | | | |
| Bedrm Func | C+ | Average Plus | | | |
| Stories | 1 | 1 Story | | | |
| Occupancy | 0 | | | | |
| Interior Wall 1 | 05 | Drywall | | | |
| Interior Wall 2 | | | | | |
| Interior Floor 1 | 14 | Carpet | | | |
| Interior Floor 2 | | | | | |
| Heat Fuel | 04 | Electric | | | |
| Heat Type | 07 | Elec Baseboard | | | |
| AC Type | 03 | Central | | | |
| Bedrooms | 02 | 2 Bedrooms | | | |
| Full Baths | 1 | 1 Full | | | |
| Half Baths | 1 | | | | |
| Extra Fixtures | | | | | |
| Total Rooms | 5 | 5 Rooms | | | |
| Bath Style | | | | | |
| Kitchen Style | | | | | |
| Master Deed L | 1357 | | | | |
| Bath Split | 11 | 1 Full-1 Half | | | |
| Foundation | 01 | Poured Conc. | | | |
| AC Type Alt | | | | | |
| Sewer Occupan | | | | | |
| CONDO DATA | | | | | |
| Parcel Id | 104194 | C 0030 | Ownr | 3.4 | |
| | WIANNO KNOLL | B 1 | S 1 | | |
| Adjust Type | Code | Description | Factor% | | |
| Condo Flr | | | 100 | | |
| Condo Unit | MKT0 | MKT0 | 100 | | |
| COST / MARKET VALUATION | | | | | |
| Building Value New | | 741,550 | | | |
| Year Built | | 1983 | | | |
| Effective Year Built | | 2001 | | | |
| Depreciation Code | | A | | | |
| Remodel Rating | | | | | |
| Year Remodeled | | | | | |
| Depreciation % | | 14 | | | |
| Functional Obsol | | 0 | | | |
| External Obsol | | 0 | | | |
| Trend Factor | | 1 | | | |
| Condition | | | | | |
| Condition % | | | | | |
| Percent Good | | 86 | | | |
| Cns Sect Rcnd | | 637,700 | | | |
| Dep % Ovr | | | | | |
| Dep Ovr Comment | | | | | |
| Misc Imp Ovr | | | | | |
| Misc Imp Ovr Comment | | | | | |
| Cost to Cure Ovr | | | | | |
| Cost to Cure Ovr Comment | | | | | |

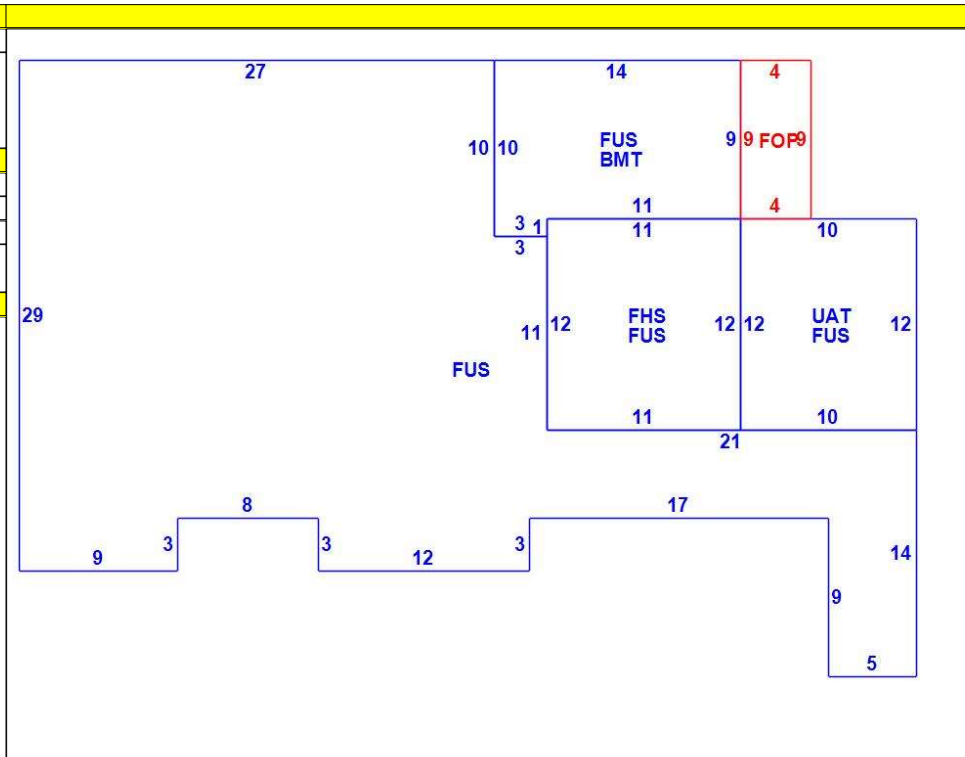

| OB - OUTBUILDING & YARD ITEMS(L) / XF - BUILDING EXTRA FEATURES(B) | | | | | | | | | | |
|--|-----------------|-----|-------|------------|--------|----------|------|-------|------------|-------------|
| Code | Description | L/B | Units | Unit Price | Yr Blt | Cond. Cd | % Gd | Grade | Grade Adj. | Appr. Value |
| FOP | Open Porch-ro | B | 36 | 55.00 | 2003 | | 86 | | 0.00 | 2,300 |
| FPL1 | Fireplace 1 sto | B | 1 | 5000.00 | 2003 | | 86 | | 0.00 | 4,300 |
| BMT | Basement-Unfi | B | 129 | 26.01 | 2003 | | 86 | | 0.00 | 5,200 |

| BUILDING SUB-AREA SUMMARY SECTION | | | | | | |
|-----------------------------------|-------------------|-------------|------------|----------|-----------|----------------|
| Code | Description | Living Area | Floor Area | Eff Area | Unit Cost | Undeprec Value |
| BMT | Basement Area | 0 | 129 | 0 | 0.00 | 0 |
| FHS | Half Story | 66 | 132 | 66 | 260.74 | 34,418 |
| FOP | Open Porch | 0 | 36 | 0 | 0.00 | 0 |
| FUS | Upper Story | 1,344 | 1,344 | 1,344 | 521.48 | 700,874 |
| UAT | Attic, Unfinished | 0 | 120 | 12 | 52.15 | 6,258 |
| Ttl Gross Liv / Lease Area | | 1,410 | 1,761 | 1,422 | | 741,550 |

