

CURRENT OWNER		TOPO	UTILITIES	STRT / ROAD	LOCATION	CURRENT ASSESSMENT						801 FY2024 BARNSTABLE, MA VISION						
BRESNAHAN, PATRICK 87 EAST BAY ROAD OSTERVILLE MA 02655						Description	Code	Assessed	Assessed									
						RESIDNTL	1020	475,100	475,100									
SUPPLEMENTAL DATA						Total												
		Alt Prcl ID		Plan Ref. 363/88-95														
		Split Zonin RC;BA		Land Ct#														
		BID Parcel		#SR														
		ResExpt Q		Life Estate														
		#DL 1 UNIT G5		PP STATU														
		#DL 2 BLDG G		Assoc Pid#														
		GIS ID F_961840_2691249																
RECORD OF OWNERSHIP		BK-VOL/PAGE	SALE DATE	Q/U	V/I	SALE PRICE	VC	PREVIOUS ASSESSMENTS (HISTORY)										
BRESNAHAN, PATRICK		35225 257	07-01-2022	Q	I	500,000	00	Year	Code	Assessed	Year	Code	Assessed					
GALLAGHER, JOHN J III & PAUL T TRS		35225 256	03-30-2017	U	I	0	1F	2023	1020	432,400	2022	1020	287,700					
GALLAGHER, ANNE H ET AL TRS		27260 0264	04-03-2013	U	I	1	1F											
GALLAGHER, JOHN J III TR		3485 0105	05-15-1982	U	V	0												
		Total						Total		432,400	Total		287,700					
								Total			Total		291,000					
EXEMPTIONS			OTHER ASSESSMENTS					This signature acknowledges a visit by a Data Collector or Assessor										
Year	Code	Description	Amount	Code	Description	Number	Amount	Comm Int										
		Total				0.00												
ASSESSING NEIGHBORHOOD																		
Nbhd		Nbhd Name		B		Tracing		Batch										
0001								OSTVIL										
NOTES																		
BUILDING PERMIT RECORD																		
Permit Id	Issue Date	Type	Description	Amount	Insp Date	% Comp	Date Comp	Comments	Date	Id	Type	Is	Cd	Purpost/Result				
									05-26-2021	BM	03		16	In Office Review				
									06-03-2020	WD			FR	Field Review				
									05-20-2019	SR	02		03	Cycl Insp Comp				
									07-29-2015	TP	03		16	In Office Review				
									08-22-2014	TP	03		16	In Office Review				
									03-28-2014	TR	22		22	Change of Address				
									07-25-2013	DR	03		16	In Office Review				
LAND LINE VALUATION SECTION																		
B	Use Code	Description	Zone	Dist	Land Type	Land Units	Unit Price	Size Adj	Site Index	Cond.	Nbhd.	Nbhd. Adj	Notes	Location Adjustmen	Adj Unit P	Land Value		
1	102U	Condominium M	SPLI	3		0 SF	0.00	1.00000	5	1.00	0001	1.000		0.0000	0	0		
Total Card Land Units						0 SF	Parcel Total Land Area						0.00	Total Land Value				0

CONSTRUCTION DETAIL			CONSTRUCTION DETAIL (CONTINUED)		
Element	Cd	Description	Element	Cd	Description
Style	55	Condominium			
Model	05	Res Condo			
Bedrm Func	C+	Average Plus			
Stories	1	1 Story			
Occupancy	0				
Interior Wall 1	05	Drywall			
Interior Wall 2					
Interior Floor 1	14	Carpet			
Interior Floor 2					
Heat Fuel	04	Electric			
Heat Type	07	Elec Baseboard			
AC Type	03	Central			
Bedrooms	02	2 Bedrooms			
Full Baths	2	2 Full			
Half Baths	0				
Extra Fixtures					
Total Rooms	5	5 Rooms			
Bath Style					
Kitchen Style					
Master Deed L	947				
Bath Split	20	2 Full-0 Half			
Foundation	01	Poured Conc.			
AC Type Alt					
Sewer Occupan					
CONDO DATA					
Parcel Id	104194	C 0030	Owne	2.9	
	WIANNO KNOLL	B 1	S 1		
Adjust Type	Code	Description	Factor%		
Condo Flr			100		
Condo Unit	MKT0	MKT0	100		
COST / MARKET VALUATION					
Building Value New			540,832		
Year Built			1983		
Effective Year Built			2001		
Depreciation Code			A		
Remodel Rating					
Year Remodeled					
Depreciation %			14		
Functional Obsol			0		
External Obsol			0		
Trend Factor			1		
Condition					
Condition %					
Percent Good			86		
Cns Sect Rcnd			465,100		
Dep % Ovr					
Dep Ovr Comment					
Misc Imp Ovr					
Misc Imp Ovr Comment					
Cost to Cure Ovr					
Cost to Cure Ovr Comment					

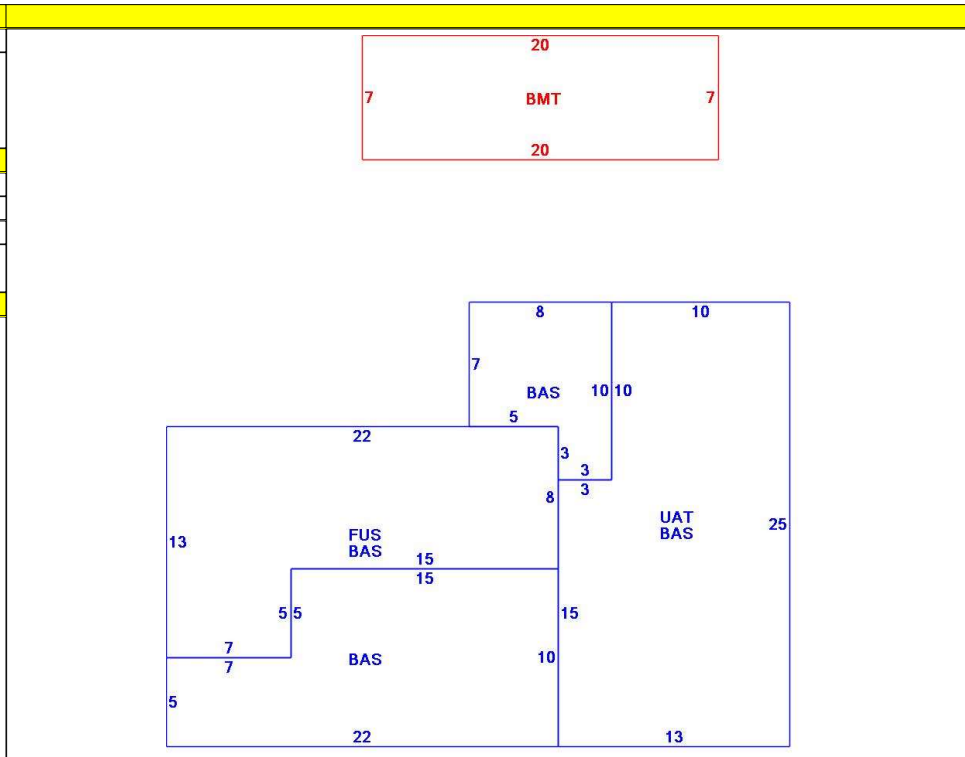

OB - OUTBUILDING & YARD ITEMS(L) / XF - BUILDING EXTRA FEATURES(B)

Code	Description	L/B	Units	Unit Price	Yr Blt	Cond. Cd	% Gd	Grade	Grade Adj.	Appr. Value
BMT	Basement-Unfi	B	140	26.01	2003		86		0.00	5,700
FPL1	Fireplace 1 sto	B	1	5000.00	2003		86		0.00	4,300

BUILDING SUB-AREA SUMMARY SECTION

Code	Description	Living Area	Floor Area	Eff Area	Unit Cost	Undeprec Value
BAS	First Floor	756	756	756	542.46	410,099
BMT	Basement Area	0	140	0	0.00	0
FUS	Upper Story	211	211	211	542.46	114,459
UAT	Attic, Unfinished	0	295	30	55.17	16,274
Ttl Gross Liv / Lease Area		967	1,402	997		540,832

